

OKLAHOMA SCHOOL TESTING PROGRAM

TEST BLUEPRINT AND ITEM SPECIFICATIONS

College- and Career-Readiness Assessment:
SCIENCE CONTENT



OKLAHOMA
Education

Important Note:

The material in the test and item specifications
should not be used as a curriculum guide.



Developed and published under contract with the Oklahoma State Department of Education by Cognia, 9115 Westside Parkway, Alpharetta, GA 30009. Copyright © 2023 by the Oklahoma State Department of Education. All rights reserved. Only State of Oklahoma educators and citizens may copy, download, and/or print this document, located online at oklahoma.onlinehelp.cognia.org. Any other use or reproduction of this document, in whole or in part, requires written permission of the Oklahoma State Department of Education and the publisher. All brand and product names found in this publication are the trademarks of their respective owners.

TABLE OF CONTENTS

Oklahoma School Testing Program	1
College- and Career-Readiness Assessment: Science Content	1
Purpose	1
Assessments According to the Oklahoma ESSA Plan	1
Test Structure, Format, and Scoring	2
Test Alignment with Oklahoma Academic Standards for Science	3
Test Blueprint	4
Correlation of Standards Across the High School Physical Science Courses	7
Cognitive Complexity Assessed by Test Items	8
Universal Design for Learning (UDL) Considerations	8
Test Administration Details	9
Online Administration	9
Paper Administration	9
Estimated Testing Time	10
Item Specifications	11
Introduction	11
General Cluster Specifications	12
Cluster Stimulus	12
Cluster Items	14
General Item Writing Mechanics	15
Multiple-Choice Items	15
Technology-Enhanced Items	15
Item Vocabulary	16
Overview of Layout of Item Specifications by Performance Expectation	17
Item Specifications by Performance Expectation	18
From Molecules to Organisms: Structure and Processes: B.LS1.1*	19
From Molecules to Organisms: Structure and Processes: B.LS1.2	26
From Molecules to Organisms: Structure and Processes: B.LS1.3	30
From Molecules to Organisms: Structure and Processes: B.LS1.4	36
From Molecules to Organisms: Structure and Processes: B.LS1.5	40
From Molecules to Organisms: Structure and Processes: B.LS1.6	44
From Molecules to Organisms: Structure and Processes: B.LS1.7	47
Ecosystems: Interactions, Energy, and Dynamics: B.LS2.1	51
Ecosystems: Interactions, Energy, and Dynamics: B.LS2.2	55
Ecosystems: Interactions, Energy, and Dynamics: B.LS2.3	60
Ecosystems: Interactions, Energy, and Dynamics: B.LS2.4*	64

**associated sample cluster included*

TABLE OF CONTENTS

Ecosystems: Interactions, Energy, and Dynamics: B.LS2.5	74
Ecosystems: Interactions, Energy, and Dynamics: B.LS2.6	78
Ecosystems: Interactions, Energy, and Dynamics: B.LS2.8	82
Heredity: Inheritance and Variation of Traits: B.LS3.1	85
Heredity: Inheritance and Variation of Traits: B.LS3.2	89
Heredity: Inheritance and Variation of Traits: B.LS3.3*	94
Biological Unity and Diversity: B.LS4.1	106
Biological Unity and Diversity: B.LS4.2*	111
Biological Unity and Diversity: B.LS4.3*	121
Biological Unity and Diversity: B.LS4.4	130
Biological Unity and Diversity: B.LS4.5	135
Matter and Its Interactions: PS.PS1.1*	140
Matter and Its Interactions: PS.PS1.2	149
Matter and Its Interactions: PS.PS1.5*	154
Matter and Its Interactions: PS.PS1.7	163
Motion and Stability: Forces and Interactions: PS.PS2.5*	167
Energy: PS.PS3.1	177
Energy: PS.PS3.2	182
Energy: PS.PS3.3*	188
Energy: PS.PS3.4	200
Waves and Their Applications in Technologies for Information Transfer: PS.PS4.1	206
Waves and Their Applications in Technologies for Information Transfer: PS.PS4.4	211
Appendix: Alignment and Cognitive Complexity Evaluation Tool.	216

**associated sample cluster included*

OKLAHOMA SCHOOL TESTING PROGRAM

College- and Career-Readiness Assessment: Science Content

Purpose

A robust assessment system is predicated upon the knowledge that no one assessment is able to provide answers to all questions affecting instructional decisions. An assessment system utilizes different types of assessment to gather multiple pieces of evidence to provide timely, relevant, actionable, and reliable information about what students know and can do relative to a set of standards.

Assessments According to the Oklahoma ESSA Plan

According to page 48 of the Oklahoma ESSA Consolidated State Plan, Oklahoma recognizes that a **robust assessment system** is tied closely to students' learning and teachers' instructional practices by valuing and promoting **local, classroom-based formative assessments** that help make **student learning visible**. At the same time, that system should provide a **strong summative assessment** program that fits as a component within a multifaceted state, district, and school accountability system.

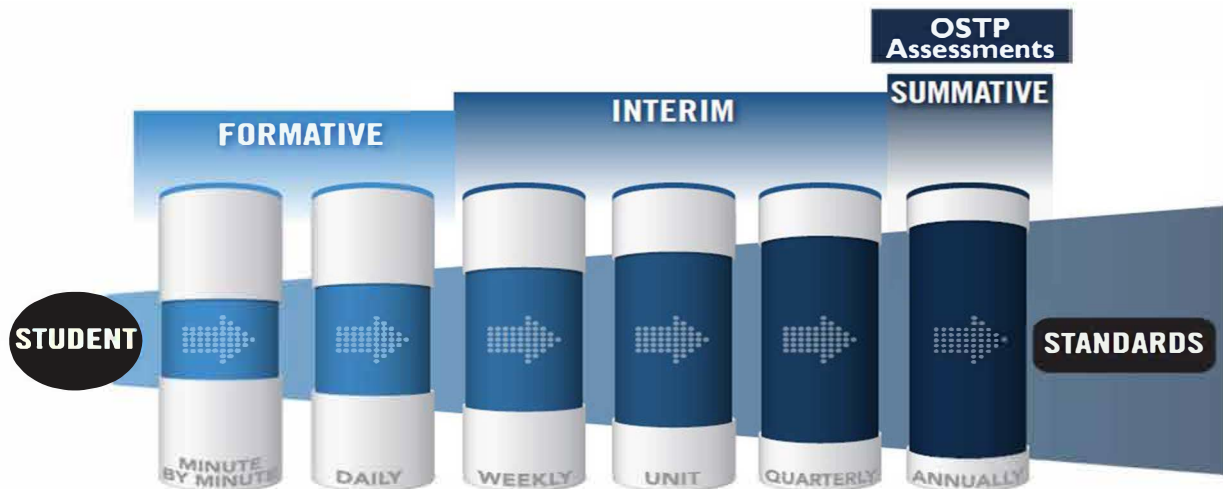

The OSDE supports an assessment system by working with Oklahoma educators and stakeholders to:

- Ensure that state and federally required annual summative assessments delivered through the Oklahoma School Testing Program (OSTP) are effective and meaningful to families, districts, educators, and members of the community;
- Develop instructional resources to support local formative and interim assessments through the curriculum frameworks projects and assessment guidance toolkit; and
- Build and deliver professional learning through face-to-face and web-based resources to support local assessment needs and interpretation of state assessment data.

Annual assessments delivered through the OSTP are aligned to the Oklahoma Academic Standards and can therefore provide point-in-time data for programmatic and curricular decisions by supporting criterion-referenced interpretations at appropriate levels and grain size (e.g., grade, student group, teacher, building/district administrator, state). Standards-based formative and interim assessments conducted at the local level can provide additional information and evidence of learning at a smaller grain size to inform instructional decisions made at the student and classroom level.

While state summative assessments are only one measure of what students know and can demonstrate, having Oklahoma students take OSTP assessments:

- ✓ Helps students, their families, and the public know how students have grown over time and how they are performing relative to the standards, their peers in Oklahoma, and the nation;
- ✓ Enables teachers to see how their students are performing against grade-level expectations communicated through the Performance Level Descriptors (PLDs) to support evaluation and enhancement of curriculum and programs for the next school year;
- ✓ Provides a standardized and reliable measure for school/district leaders, the state, policymakers, and the public to determine how well a system is meeting the goals of helping every child grow along a continuum to prepare them for careers, college, and life; and
- ✓ Provides comparable information and data to inform continuous improvement of a system and appropriately support federal and state accountability decisions.

Test Structure, Format, and Scoring

The Oklahoma School Testing Program CCRA: Science Content consists of clusters of items. A cluster is either a set of three multiple-choice items linked with a common phenomenon or a problem-based stimulus, or a set of two multiple-choice items and a technology-enhanced item linked with a common stimulus.

- A cluster stimulus consists of the passages, graphs, models, figures, diagrams, data tables, etc. that students must read and examine to respond to the items in the cluster. The stimulus may be a combination of multiple stimulus elements (e.g., some text plus a diagram and/or a data table) and it must require students to think/reason and/or engage in sense-making.
 - The elements of the stimulus must support an organizing phenomenon or problem that is used in the process.
- Each multiple-choice item within the cluster is worth one point and is scored as correct or incorrect.
- Each technology-enhanced item is worth two points and is scored as completely correct (two points), partially correct (one point), or incorrect (zero points).
- Items within a cluster are arranged logically, typically with easier and/or less complex items first.

The table below shows the total number of items (in clusters) that students respond to and the total number of points allocated on a test form. Further explanation is provided in the paragraph below the table.

Target Number of Items and Score Points for CCRA: Science Content			
Content Assessment	Total Operational Items and Points	Total Field-Test Items	Total Items
CCRA: Science Content	60 items (20 clusters) 62 points*	6 items (2 clusters)*	66 items (22 clusters)*

*Item counts and points are approximate and may vary slightly.

As shown in the table, the test form for CCRA: Science Content is designed to contain both operational clusters and field-test clusters. The operational clusters contribute to the student's score; the raw score (number of points earned on that form) is converted to a scaled score to report test results. (Note that because two of the operational clusters contain two multiple-choice items and a technology-enhanced item, rather than three multiple-choice items, the number of operational items and the number of points are not the same.) The field-test clusters do not contribute to the student's score, but the results are used to evaluate new clusters for use in future operational forms. Clusters that have suitable statistics are used to construct operational tests in subsequent years.

Each cluster aligns to a single OAS-S standard (consisting of a Science and Engineering Practice, Disciplinary Core Ideas, and Crosscutting Concept). The clusters are also structured to assess a range of skills and knowledge applications as it relates to the three dimensions of the standard. In this way, the assessment will gather data measuring a breadth and depth of student ability within the specific standard and across concepts in biology and the physical sciences (chemistry, physics, physical science).

Test Alignment with Oklahoma Academic Standards for Science

Criteria for Aligning the Test with the Oklahoma Academic Standards Content Standards

1. Range of Knowledge Correspondence

Each administration of the assessment will be comprised of approximately 50% life science content and approximately 50% physical science content. The CCRA: Science Content is constructed so that a minimum of 75% of the assessable standards in Physical Science have at least one corresponding cluster of items in the operational portion of the assessment. For Life Sciences, because of the much larger number of assessable standards, only about 40% of the standards will have a corresponding cluster of items in the operational portion of the assessment in any given year. However, all standards in both the life and physical sciences will be assessed over time.

2. Categorical Concurrence

The CCRA: Science Content is constructed so that there are 28–34 score points measuring each reporting category. This number of points well exceeds the typical psychometric recommendations for a minimum of 10–12 score points needed to produce a reasonably reliable estimate of a student's mastery of the constructs measured.

3. Consistency of Cognitive Complexity

On the CCRA: Science Content, the items in the clusters require students to use various levels of cognitive complexity. Because items in a cluster are structured to assess a range of skills and knowledge applications within a standard, the level of complexity of the items (and therefore the cognitive demand required of students) will vary for individual assessment items. In general, the cognitive complexity of the assessment items will be reflective of the complexity described in the three dimensions of the standard.

OKLAHOMA SCHOOL TESTING PROGRAM TEST BLUEPRINT SCIENCE GRADE 11



This blueprint describes the content and structure of the CCR Science Content Assessment and defines the ideal range of test items by reporting category of the [Oklahoma Academic Standards – Science \(OAS-S\)](#).

REPORTING CATEGORIES

PHYSICAL SCIENCES 45 - 55%

- PS.PS1.1** Use the periodic table as a model to predict the relative properties of elements based on the patterns of electrons in the outermost energy level of atoms.
- PS.PS1.2** Construct and revise an explanation for the outcome of a simple chemical reaction based on the outermost electron states of atoms, trends in the periodic table, knowledge of the patterns of chemical properties, and formation of compounds.
- PS.PS1.5** Apply scientific principles and evidence to provide an explanation about the effects of changing the temperature or concentration of the reacting particles on the rate at which a reaction occurs.
- PS.PS1.7** Use mathematical representations to support the claim that atoms, and therefore mass, are conserved during a chemical reaction.
- PS.PS2.5** Plan and conduct an investigation to provide evidence that an electric current can cause a magnetic field and that a changing magnetic field can cause an electric current.
- PS.PS3.1** Create a computational model to calculate the change in the energy of one component in a system when the change in energy of the other component(s) and energy flows in and out of the system are known.
- PS.PS3.2** Develop and use models to illustrate that energy at the macroscopic scale can be accounted for as either motions of particles or energy stored in fields.
- PS.PS3.3** Design, build, and refine a device that works within given constraints to convert one form of energy into another form of energy.
- PS.PS3.4** Plan and conduct an investigation to provide evidence that the transfer of thermal energy when two components of different temperature are combined within a closed system results in a more uniform energy distribution among the components in the system (second law of thermodynamics).
- PS.PS4.1** Use mathematical representations to explain both qualitative and quantitative relationships among frequency, wavelength, and speed of waves traveling in various media.
- PS.PS4.4** Evaluate the validity and reliability of claims in published materials of the effects that different frequencies of electromagnetic radiation have when absorbed by matter.



LIFE SCIENCES 45 - 55%

- B.LS1.1** Construct an explanation based on evidence for how the structure of DNA determines the structure of proteins, which carry out the essential functions of life through systems of specialized cells.
- B.LS1.2** Develop and use a model to illustrate the hierarchical organization of interacting systems that provide specific functions within multicellular organisms.
- B.LS1.3** Plan and conduct an investigation to provide evidence of the importance of maintaining homeostasis in living organisms.
- B.LS1.4** Use a model to illustrate the role of cellular division (mitosis) and differentiation in producing and maintaining complex organisms.
- B.LS1.5** Use a model to illustrate how photosynthesis transforms light energy into stored chemical energy.
- B.LS1.6** Construct and revise an explanation based on evidence for how carbon, hydrogen, and oxygen from sugar molecules may combine with other elements to form amino acids and/or other large carbon-based molecules.
- B.LS1.7** Use a model to illustrate that cellular respiration is a chemical process whereby the bonds of food molecules and oxygen molecules are broken and the bonds in new compounds are formed resulting in a net transfer of energy.
- B.LS2.1** Use mathematical and/or computational representations to support explanations of factors that affect carrying capacity of ecosystems at different scales.
- B.LS2.2** Use mathematical representations to support and revise explanations based on evidence about factors affecting biodiversity and populations in ecosystems of different scales.
- B.LS2.3** Construct and revise an explanation based on evidence for the cycling of matter and flow of energy in aerobic and anaerobic conditions.
- B.LS2.4** Use a mathematical representation to support claims for the cycling of matter and flow of energy among organisms in an ecosystem.
- B.LS2.5** Develop a model to illustrate the role of photosynthesis and cellular respiration in the cycling of carbon among the biosphere, atmosphere, hydrosphere, and geosphere.
- B.LS2.6** Evaluate the claims, evidence, and reasoning that the complex interactions in ecosystems maintain relatively consistent numbers and types of organisms in stable conditions, but changing conditions may result in a new ecosystem.
- B.LS2.8** Evaluate evidence for the role of group behavior on individual and species' chances to survive and reproduce.
- B.LS3.1** Ask questions to clarify relationships about the role of DNA and chromosomes in coding the instructions for characteristic traits passed from parents to offspring.



- B.LS3.2** Make and defend a claim based on evidence that inheritable genetic variations may result from: (1) new genetic combinations through meiosis, (2) viable errors occurring during replication, and/or (3) mutations caused by environmental factors.
- B.LS3.3** Apply concepts of statistics and probability to explain the variation and distribution of expressed traits in a population.
- B.LS4.1** Communicate scientific information that common ancestry and biological evolution are supported by multiple lines of empirical evidence.
- B.LS4.2** Construct an explanation based on evidence that biological diversity is influenced by (1) the potential for a species to increase in number, (2) the heritable genetic variation of individuals in a species due to mutation and sexual reproduction, (3) competition for limited resources, and (4) the proliferation of those organisms that are better able to survive and reproduce in the environment.
- B.LS4.3** Apply concepts of statistics and probability to support explanations that organisms with an advantageous heritable trait tend to increase in proportion to organisms lacking this trait.
- B.LS4.4** Construct an explanation based on evidence for how natural selection leads to adaptation of populations.
- B.LS4.5** Evaluate the evidence supporting claims that changes in environmental conditions may result in (1) increases in the number of individuals of some species, (2) the emergency of new species over time, and (3) the extinction of other species.

Standards will be assessed using a cluster-based format: a set of three multiple-choice items linked with a common stimulus or a set of two multiple-choice items and a technology-enhanced item linked with a common stimulus. The CCR Science Content test consists of some clusters containing only multiple-choice items and some clusters containing both multiple-choice and technology-enhanced items. Each cluster will align to a single standard with its associated Disciplinary Core Idea(s), Science and Engineering Practice, and Cross Cutting Concept.

The CCR Science Content operational test will contain a total of 20 operational clusters and 2 field test clusters.

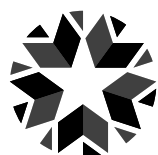

Correlation of Standards Across the High School Physical Science Courses

Students enrolled in any of the three physical science courses will be prepared for the CCRA: Science Content when taken with biology. All courses should be fully aligned to their specific academic standards for that course (chemistry, physics, physical science). Classes that are well aligned to the standards will ensure all students are adequately prepared for the CCRA: Science Content as well as college and career pathways. This table shows the correlations of standards across the high school physical science courses.

CCRA: Science Content Correlations in the Physical Sciences		
Assessed Standards (Physical Science)	Correlations in Chemistry	Correlations in Physics
PS.PS1.1	PS.PS1.1	PS.PS1.8
PS.PS1.2	PS.PS1.2	
PS.PS1.5	PS.PS1.5	PS.PS3.2 PS1.5 connects to homeostasis, concentration gradients, metabolism, and diffusion in biology.
PS.PS1.7	PS.PS1.7	PS.PS1.8 PS.PS1.7 can be applied to both photosynthesis and cellular respiration. Ecological cycles, carbon sequestering, and biomass in trophic levels are also relevant topics in life sciences.
PS.PS2.5	PS.PS2.6 PS.PS3.3 PS.PS4.3	PS.PS2.5
PS.PS3.1	PS.PS1.4 PS.PS1.8 PS.PS2.6 PS.PS3.3 PS.PS3.4	PS.PS3.1
PS.PS3.2	PS.PS1.4 PS.PS1.5 PS.PS1.8 PS.PS2.6 PS.PS3.3 PS.PS3.4 PS.PS4.3	PS.PS3.2
PS.PS3.3	PS.PS3.3	PS.PS3.3
PS.PS3.4	PS.PS3.4	PS.PS3.4
PS.PS4.1	PS.PS4.1	PS.PS4.1
PS.PS4.4	PS.PS4.1 PS.PS4.3	PS.PS4.4

Cognitive Complexity Assessed by Test Items

The CCRA: Science Content will have items within a cluster structured to assess a range of skills and knowledge applications within a standard. Clusters require sense-making and problem solving using the three dimensions. Sense-making happens when students have to apply, via the science and engineering practices, their understanding of core ideas and crosscutting concepts to address the uncertainty associated with a scenario. The degree of sense-making required to complete an item is directly correlated to the level of cognitive complexity the student must engage with, as described in the following table.

Category	Description
Scripted	<ul style="list-style-type: none"> • Only one dimension is present, or two dimensions are present but only one is used in application or reasoning for sense-making. • Heavy scaffolding <ul style="list-style-type: none"> – Scripted “Cookbook instructions” • Little to no sense making
Moderate Support	<ul style="list-style-type: none"> • Multidimensional 2-3 dimensions are evident but only one is heavily used in sense-making while the other may be used minimally. • Moderate scaffolding <ul style="list-style-type: none"> – Students have to apply ideas and practices, however they are often told which ones to engage with and supported in using them • Low to Medium degree of sense making
Low Support	<ul style="list-style-type: none"> • Multidimensional 2-3 dimensions are evident with at least 2 being necessary to use or reason with in sense-making. • Minimal scaffolding <ul style="list-style-type: none"> – Students are cued and guided to pursue certain lines of thinking, but have to make some decisions about how and what to engage • Medium to High degree of sense making <ul style="list-style-type: none"> – High; Students must connect multiple pieces of information in a novel way
Doing (rarely achievable on summative assessments)	<ul style="list-style-type: none"> • The three dimensions are used together to engage in sense-making to a high degree throughout the task • Student-designed exploration of science Limited to no scaffolding • Students work like scientists to use various scientific practices to be able to develop or deepen an understanding of a scientific idea or problem as they explore a phenomenon. In most cases if a student actually is engaged in 3 dimensions and has to develop the model, or develop the explanation or develop the argument from raw data or information, they are being asked to do science.

Note: These descriptions are adapted from Achieve.

A more detailed framework for categorizing cognitive complexity is shown in the [appendix](#).

Universal Design for Learning (UDL) Considerations

Universal Design for Learning (UDL), as applied to assessments, is a framework that provides flexibility in the way information is presented and in the ways students demonstrate knowledge and skills. This reduces barriers while maintaining high expectations for all students, including students with disabilities and students who are limited English proficient. In the Oklahoma School Testing Program, items and instructions have been designed to provide maximum readability, comprehensibility, and legibility for all students. This includes such changes as reduction of language load in content areas other than Reading, increased font size, fewer items

per page, and boxed items to assist visual focus. Specifically in the Science tests, the cluster-based design reduces the number of unique stimuli that students must process. The stimuli and items are constructed with clear wording and presentation, and they exclude extraneous information. Additionally, the vocabulary level for the CCRA: Science Content is two grade levels below (at a Grade 9 level), except for science content words.

Test Administration Details

Online Administration

During online testing, the items within a cluster will be presented one at a time. The stimulus will appear on the screen with each associated item.

For longer stimuli or items, a scroll bar will be present to allow students to scroll through the text and/or answer choices.

Students may use the embedded graphing calculator or a calculator that meets the current Oklahoma School Testing Program’s calculator policy as documented by SDE. (See sde.ok.gov/documents/ostp-accommodation-manuals-companion-documents.)

A periodic table will be provided for use during the assessment. (See oklahoma.onlinehelp.cognia.org/reference-sheets.) No other reference sheets/resource materials may be used by students during the CCRA: Science Content. All necessary formulas and information will be provided within the items.

Students will be able to use scratch paper and/or unmarked grid paper for the online CCRA: Science Content. This paper must be collected and destroyed immediately following the test. The test administrator must not look at what the student has written on the scratch paper.

Paper Administration

Paper/pencil testing is used only as a testing accommodation. In the paper/pencil test booklet, any technology-enhanced items that appear in the online test form will be replaced by paired multiple-choice items that target the same constructs.

Students may use a graphing calculator that meets the current Oklahoma School Testing Program’s calculator policy as documented by the SDE. (See sde.ok.gov/documents/ostp-accommodation-manuals-companion-documents.)

A periodic table will be provided for use during the assessment. (See oklahoma.onlinehelp.cognia.org/reference-sheets.) No other reference sheets/resource materials may be used by students during the CCRA: Science Content. All necessary formulas and information will be provided within the items.

Students will be able to use scratch paper and/or unmarked grid paper for the paper CCRA: Science Content. This paper must be collected and destroyed immediately following the test. The test administrator must not look at what the student has written on the scratch paper.

Estimated Testing Time

The CCRA: Science Content is divided into two sessions. Districts may exercise flexibility in determining how to administer the sessions. The College- and Career-Readiness Assessment: Science Content is meant to be administered in two sessions within one day or on consecutive instructional days. When testing a session, test administrators may give students additional time if they need it, but the additional time is to be given as an immediate extension of that specific testing session.

The following table provides estimates of the time required to administer the CCRA: Science Content by session. These time approximations are provided to facilitate planning administration logistics within schools and to ensure adequate testing time for all students. Actual testing times may vary from these approximations.

CCRA Science Estimated Online Testing Time	
Distributing login information	Approximately 5 minutes
Test instructions/tutorial and reviewing sample items	Approximately 20 minutes
Administering Section 1 of the CCRA Science Online Test	65–85 minutes
Administering Section 2 of the CCRA Science Online Test	65–85 minutes
Total testing time (Suggested Maximum Time: 390 minutes)	155–195 minutes

Introduction

The item specifications documentation is intended to provide guidance on the structure and content of the test material developed for the Oklahoma School Testing Program (OSTP) CCRA: Science Content. The designated high school Life Science and Physical Science standards of the Oklahoma Academic Standards for Science (OAS-S) will be assessed on the OSTP using a cluster-based format: a set of three multiple-choice items linked with a common stimulus or a set of two multiple-choice items and a technology-enhanced item linked with a common stimulus.

Functionally, the item specifications documentation represents a bridge between the constructs in the OAS-S, the Oklahoma Science Framework, the test specifications, and the test blueprint for the CCRA: Science Content. The item specifications delineate core emphases, examples, and boundaries for item clusters written for each OAS-S performance expectation as well as expectations for the format and structure of the cluster stimuli and items. In this way, the item specifications help ensure that the item clusters appearing on the CCRA: Science Content consistently and accurately reflect the constructs in the OAS-S and validly measure students' proficiency in the performance expectations of the OAS-S.

The information utilized for the specifications for each CCRA: Science Content draws extensively from the OAS-S and from the Oklahoma Science Framework, thus providing a strong link between instruction and assessment. The information in the item specifications is also informed by the tenets in *A Framework for K–12 Science Education*¹ and recognized best practices in assessment (*Standards for Educational and Psychological Testing*,² *Code of Fair Testing Practices in Education*³).

The item specifications are intended to be used by multiple audiences: Oklahoma educators, Oklahoma State Department of Education staff, and testing vendors. The item specifications provide outlines and suggestions for the types of content and presentation that can be utilized in developing the item clusters for the CCRA: Science Content. As such, the item specifications provide all users with information to gauge the types of skills and understandings that students will be asked to demonstrate on the CCRA: Science Content. This information is useful to Oklahoma educators in planning instruction and conducting classroom formative and summative assessment. It is also useful to Oklahoma educators and State Department of Education staff in reviewing and approving item clusters for use on the CCRA: Science Content because it provides a clearly delineated description of the intent of each standard and what should be measured.

1 National Research Council. (2011). *A Framework for K–12 Science Education: Practices, Crosscutting Concepts, and Core Ideas*. Committee on a Conceptual Framework for New K–12 Science Education Standards. Board on Science Education, Division of Behavioral and Social Sciences and Education. Washington, DC: The National Academies Press.

2 American Educational Research Association, American Psychological Association, and National Council on Measurement in Education (2014). *Standards for Educational and Psychological Testing*. Washington, DC: American Educational Research Association.

3 *Code of Fair Testing Practices in Education (2004)*. Washington, DC: Joint Committee on Testing Practices.

General Cluster Specifications

The designated high school Life Science and Physical Science standards of the OAS-S will be assessed on the OSTP using a cluster-based format: a set of three multiple-choice items linked with a common stimulus or a set of two multiple-choice items and a technology-enhanced item linked with a common stimulus. The CCRA: Science Content consists of some clusters containing only multiple-choice items and some clusters containing both multiple-choice and technology-enhanced items.

A cluster requires students to actively use the Science and Engineering Practice of the performance expectation while applying their knowledge of the Crosscutting Concept and drawing on their understanding of the Disciplinary Core Ideas to explain a phenomenon or to solve a science/engineering problem. This process requires students to engage with sense-making as they actively reason and think about a phenomenon/problem.

Cluster Stimulus

A **cluster stimulus** consists of the passages, graphs, models, figures, diagrams, data tables, etc. that students must read and examine in order to respond to the items in the phenomena- or problem-based cluster. To meet the intent of the OAS-S, stimuli must represent a variety of topics, scenarios, and phenomena, many of them novel. An individual stimulus may be a combination of multiple stimulus elements (e.g., some text plus a diagram and a data table).

While the specific content and context requirements of a stimulus will vary depending on the standard being assessed (and are outlined in the individual specification for each standard), the following characteristics are necessary for all cluster stimuli:

- Information in the stimulus is representative of the Science and Engineering Practice, Disciplinary Core Idea(s), and Crosscutting Concept for a specific standard.
- The stimulus presents a phenomenon or a science and engineering problem that is engaging, realistic, meaningful, and appropriate for Oklahoma students in a high school science course.
- The stimulus includes a phenomenon/problem students would want to figure out or know more about, which is aligned with the core emphasis of the performance expectation. When students are given information, data, or an experimental setup to evaluate, they should know the research question and/or purpose of the research when applicable. The phenomenon/problem must be integral to the item, not gratuitous, and necessary for students to reason, think through, or use in sense-making to answer all items in the cluster.
- The stimulus provides sufficient information (in the form of tables, graphs, text, diagrams, etc.) for the assessment of a specific standard. In other words, the stimulus must supply sufficient information to allow students to engage in the Science and Engineering Practice of the performance expectation in conjunction with the Disciplinary Core Ideas and Crosscutting Concept to respond to items.
- The stimulus information must be necessary, but not conceptually sufficient, for the student response (i.e., students **must** also utilize their own knowledge of the constructs in the performance expectation to answer the items).
- The information included within the stimulus must pertain to multiple items. Unique lead information that supports only one item will be placed in the introduction to that particular item. Extraneous information should be eliminated from the cluster stimulus and from item lead information (i.e., only relevant, concise information is utilized in order to reduce information overload).

- There is a balance of graphic and textual stimulus materials among the set of clusters for the test form. The pictorial and graphic representations in the stimulus are appropriate for the grade level and standard being assessed. The stimulus (text and graphic elements) is presented on the screen in the layout that best facilitates student accessibility. Scrolling is minimized when possible.
- The placement of graphic and textual materials within the stimulus follows a logical flow of information. This is facilitated by the use of clear language, transitions, and pointers between text and graphics.
- The stimulus avoids material or subject matter that might introduce bias or sensitivity issues:
 - a. The material is balanced and culturally diverse.
 - b. There is a balance of gender and active/passive roles by gender.
 - c. The stimulus does not display unfair representations of gender, race, ethnicity, disability, culture, or religion; nor does the stimulus contain elements that are offensive to any such groups.
 - d. The content of the stimulus avoids subject matter that might prompt emotional distress on the part of the students.
- The content of the stimulus is developed and verified using valid and reliable scientific sources for contexts, examples, and data.
- Permission to use stimuli from copyrighted material is obtained as necessary by the testing vendor.
- The stimulus supports the development of 6–8 associated items. (While clusters will contain only three items on the operational test, additional items must be field-tested with the stimulus to ensure enough items are available to construct the operational clusters. Items are sometimes rejected after the field test if the performance data for the item do not meet psychometric requirements.)
- Careful attention is given to the wording, length, and complexity of the stimulus:
 - word count of approximately 50–300 words
 - vocabulary level two to three grade levels below (at a Grade 8–9 level), except for science content words
 - use of footnotes to define unfamiliar science content words (exception: one-word parentheticals may be used)
 - focus on shorter sentence structure and less complex grammatical constructions
 - consideration of qualitative and quantitative readability measures to review text complexity

Note: The exact vocabulary, word count, and complexity of each stimulus will be reviewed by Oklahoma educators and approved by the Oklahoma State Department of Education to achieve the most appropriate stimulus for each cluster based on the grade level and content being assessed.

Cluster Items

The items within each cluster must work together cohesively to provide a valid measure of the standard being assessed. The flow of the item should also progressively develop student sense-making while avoiding being dependent on prior items. The following criteria should guide the development of items in each cluster:

- The items are tied closely to their specific stimulus and the associated phenomenon/problem so that the impact of non-curricular knowledge and experience, while never wholly avoidable, is minimized.
- The items cover the concepts, information, and evidence that are central to students' understanding of the specific cluster stimulus and are focused on the Science and Engineering Practice, Disciplinary Core Ideas, and Crosscutting Concept of the performance expectation. Across an item set it must be clearly evident that students have used all three dimensions of the given standard.
- The items do not assess Science and Engineering Practices that are not part of the performance expectation that the cluster is aligned to.
- The items within a cluster address different depths and breadths of understanding of the specific performance expectation. Items within a cluster may represent a range of cognitive complexity but overall the complexity of the cluster will reflect the cognitive complexity called for by the standards.
- The model item stems described in the specifications for each performance expectation are utilized whenever possible. The model item stems represent general ways (and specific ways, in brackets) to assess the multiple dimensions of each standard. The model item stems are not meant to be an exhaustive listing; rather, they represent a selection that can be used with an appropriate stimulus to craft well-aligned items. Other stems may be used in place of these model item stems, but they must capture multiple dimensions such that the finished cluster shows alignment to all three dimensions of the standard.
- Graphics and information for all cluster items are generally placed in the cluster stimulus, but items may have additional information or graphics when necessary. (Unique lead information supporting only one item will be placed in the introduction to that specific item.) Graphics must be clearly associated with their intended items.
- Each item in the cluster is independent of the other items; that is, the answer to one item is not required to answer the other items.
- To the greatest extent possible, no item or answer choice clues the correct answer to any other item.
- The items in the cluster are presented to the student one at a time online. The stimulus appears on the screen with each item in the cluster.

General Item Writing Mechanics

All items written during the development of the item clusters for the CCRA: Science Content will follow best practices in assessment pertaining to the structure and format of the items per item type. Consideration is also given to vocabulary word choices.

Multiple-Choice Items

- Each multiple-choice item has a stem (formatted as a question or an incomplete statement) and four answer options, only one of which is correct.
- All item stems clearly indicate what is expected in the item to help students focus on selecting a response. The stem presents a complete problem so that students know what to do before looking at the answer choices; students should not need to read all the answer choices before knowing what is expected.
- All multiple-choice options—the correct response and the three distractors—are similar in length and syntax. Students should not be able to rule out an incorrect answer or identify a correct response solely because it looks or sounds different from the other answer choices. Distractors are created so that students reason their way to the correct answer rather than simply identify incorrect responses because of a distractor’s obviously inappropriate nature. Distractors should always be plausible (but incorrect) in the context of the item stem.
- Any art within individual items (e.g., additional lead art, graphic options) must be functional and necessary for the item.
- Most item stems are positively worded and avoid the use of the word “not.” If a negative is required, the preferred format is “All of the following . . . except.”
- The responses “Both of the above,” “All of the above,” “None of the above,” and “Neither of the above” are not used as options.

Technology-Enhanced Items

- Technology-enhanced items should be used to more authentically address some aspects of the OAS-S performance expectations and/or to provide more opportunity for students to construct rather than select their response.
- Interaction types are match, hot-spot, drag-drop, ordering, graphing, and drop-down. Each technology-enhanced item contains only one interaction type per item.
- For each technology-enhanced item, the interaction type used is that which is the most appropriate and enhancing to the construct to be measured.
- Each technology-enhanced item is structured to contain the question (content) first, followed by directions on how to complete the interaction in that item. Consistent style and language are used in these directions (e.g., “Drag the following events in the order in which they occurred.”)
- Each technology-enhanced item is worth two points. Students may earn two, one, or zero points for their response; the scoring rubric will define responses that are completely correct and partially correct based on the skill and understanding being assessed.
- Note that for each technology-enhanced item that is authored, a paired multiple-choice item is also created for the paper accommodation. Each paired multiple-choice item consists of two linked multiple-choice questions and assesses information similar to that in the technology-enhanced item. The paired multiple-choice item, like the technology-enhanced item, is worth two points.

Item Vocabulary

- No single source is available to determine the reading level of various words. Therefore, the appropriateness and difficulty of a word is determined in various ways. Vocabulary is checked in the following: *EDL Core Vocabularies in Reading, Mathematics, Science, and Social Studies*; *Basic Reading Vocabularies*; the *Living Word*; or other reliable readability sources.
- In addition, each vocabulary word must be approved by Oklahoma’s Content Review Committee. The committee, composed of Oklahoma educators from across the state, reviews proposed vocabulary in item clusters for grade-level appropriateness.
- Except for science content words, the CCRA: Science Content will have a vocabulary level two grade levels below (at a Grade 9 level).
- Unfamiliar science words in stimuli are to be defined using footnotes. The exception to this is single-word definitions, which may be placed in parentheses [e.g., mean (average)].

Overview of Layout of Item Specifications by Performance Expectation

For each OAS-S performance expectation, the item specifications are organized in the following way:

Core Idea Category: Performance Expectation Code ¹																														
Performance Expectation Code and Text²			<ol style="list-style-type: none"> 1 Core idea category and code for each performance expectation from the OAS-S (e.g., Biological Unity and Diversity, B.LS4.5) 2 Coding and text of the performance expectation from the OAS-S 3 Clarification statement for the performance expectation from the OAS-S 4 Assessment boundary for the performance expectation from the OAS-S 5 Science & Engineering Practice, Disciplinary Core Idea, and Crosscutting Concept that underpin the performance expectation from the OAS-S 6 Description of the basic meaning and intent of the performance expectation in easily understandable terms 7 Additional details, clarifications, and content limits needing to be conveyed 8 Specific information about the typical features of the stimuli for clusters aligned to this performance expectation 9 Item types that may comprise the item clusters 10 Descriptions of possible item stems/starters that could be included in clusters for this performance expectation; i.e., general statements (and/or specific statements, in brackets) of ways to assess each performance expectation are given 11 Common student misconceptions related to the performance expectation, to be used when writing items (web-links were active as of 4/2022) 12 Example of a cluster for this performance expectation (*will eventually be available for all clusters) 																											
OAS-S Clarification Statement:³																														
OAS-S Assessment Boundary:⁴																														
Science & Engineering Practice:⁵	Disciplinary Core Idea:	Crosscutting Concept:																												
In Lay Terms:⁶																														
Cluster Clarifications:⁷																														
Cluster Stimulus Attributes:⁸ Typical stimulus elements: Possible contexts: Content and evidence to be included: Types of student responses that need to be supported: Allowable Item Types: ⁹																														
Model Item Descriptions for Performance Expectation:¹⁰ <table border="1" style="width: 100%; border-collapse: collapse;"> <thead> <tr> <th style="width: 15%;">Item Type</th> <th style="width: 45%;">Model Stem</th> <th style="width: 40%;">Response Characteristics*</th> </tr> </thead> <tbody> <tr><td>MC</td><td></td><td></td></tr> <tr><td>MC</td><td></td><td></td></tr> <tr><td>MC</td><td></td><td></td></tr> <tr><td>MC</td><td></td><td></td></tr> <tr><td>MC</td><td></td><td></td></tr> <tr><td>MC</td><td></td><td></td></tr> <tr><td>MC</td><td></td><td></td></tr> <tr><td>MC</td><td></td><td></td></tr> </tbody> </table>				Item Type	Model Stem	Response Characteristics*	MC			MC			MC			MC			MC			MC			MC			MC		
Item Type	Model Stem	Response Characteristics*																												
MC																														
MC																														
MC																														
MC																														
MC																														
MC																														
MC																														
MC																														
Student Misconceptions: *Response options can make use of Student Misconceptions (examples of scientifically incorrect assumptions) related to this performance expectation; references to misconceptions are listed below: ¹¹ <div style="border: 1px solid black; height: 20px; width: 100%; margin-top: 5px;"></div>																														
Sample Cluster for Performance Expectation:¹² <div style="border: 1px solid black; height: 100px; width: 100%; margin-top: 5px;"></div>																														

Item Specifications by Performance Expectation

B.LS1.1: page 19*

B.LS1.2: page 26

B.LS1.3: page 30

B.LS1.4: page 36

B.LS1.5: page 40

B.LS1.6: page 44

B.LS1.7: page 47

B.LS2.1: page 51

B.LS2.2: page 55

B.LS2.3: page 60

B.LS2.4: page 64*

B.LS2.5: page 74

B.LS2.6: page 78

B.LS2.8: page 82

B.LS3.1: page 85

B.LS3.2: page 89

B.LS3.3: page 94*

B.LS4.1: page 106

B.LS4.2: page 111*

B.LS4.3: page 121*

B.LS4.4: page 130

B.LS4.5: page 135

PS.PS1.1: page 140*

PS.PS1.2: page 149

PS.PS1.5: page 154*

PS.PS1.7: page 163

PS.PS2.5: page 167*

PS.PS3.1: page 177

PS.PS3.2: page 182

PS.PS3.3: page 188*

PS.PS3.4: page 200

PS.PS4.1: page 206

PS.PS4.4: page 211

**associated sample cluster included*

Important Note:

The material in the test and item specifications should not be used as a curriculum guide.

The item specifications provide guidelines and suggestions for the type of content to be included in item clusters, but they do not provide an exhaustive list of what can be included. The cluster stimulus attributes, model item descriptions, and sample item clusters are not intended to be completely definitive in nature or construction—the cluster stimuli and items may differ from one test form to another, as may their presentations.

All item clusters are expected to be of the highest quality and be tightly aligned to the OAS-S. All item clusters developed using these specifications are reviewed by Oklahoma educators and approved by the Oklahoma State Department of Education.

From Molecules to Organisms: Structure and Processes: B.LS1.1*

back to “Item Specifications by Performance Expectation”

B.LS1.1. Construct an explanation based on evidence for how the structure of DNA determines the structure of proteins, which carry out the essential functions of life through systems of specialized cells.

OAS-S Clarification Statement:

Emphasis is on the conceptual understanding that the sequence of nucleotides in DNA determines the amino acid sequence of proteins through the processes of transcription and translation.

OAS-S Assessment Boundary:

Assessment does not include identification of specific cell or tissue types, whole body systems, specific protein structures and functions, or the biochemistry of protein synthesis.

Science & Engineering Practice:

Constructing Explanations

- Construct and revise an explanation based on valid and reliable evidence obtained from a variety of sources (including students’ own investigations, models, theories, simulations, peer review) and the assumption that theories and laws that describe the natural world operate today as they did in the past and will continue to do so in the future.

Disciplinary Core Idea:

Structure and Function

- Systems of specialized cells within organisms help them perform the essential functions of life.
- All cells contain genetic information in the form of DNA molecules.
- Genes are regions in the DNA that contain the instructions that code for the formation of proteins, which carry out most of the work of cells.

Crosscutting Concept:

Structure and Function

- The functions and properties of natural and designed objects and systems can be inferred from their overall structure, the way their components are shaped and used, and the molecular substructures of their various materials.

In Lay Terms:

Students should be able to explain how molecules called DNA serve as the instructions that all living organisms use to produce proteins, which in turn perform essential functions of life.

Cluster Clarifications:

- Items will not ask students to memorize which specific codons produce which amino acid by name. Codon charts can be provided as a reference (being clear about DNA vs. RNA code).
- Item focus should be on the interrelationships of components and the conceptual process, and not on nomenclature/mechanics.
- In order to address the CCC, stimuli should involve, and items should address, how the function of DNA and proteins *relate to* structure(s) in cells and/or organisms.
- For clusters with a mutation context, the stimulus should show a mutation that still allows a protein to be produced, but in an altered form (rather than a mutation that prevents a protein from being produced at all).
- In order to address the SEP, real data showing the expression of proteins must be used, including proteins that show codominant expression. However, the specifics of the codominant inheritance pattern is not to be discussed in stimulus or items.

**associated sample cluster included*

From Molecules to Organisms: Structure and Processes: B.LS1.1*

Cluster Stimulus Attributes:

Typical stimulus elements:

- student scientific writings or presentations and/or physical models that communicate starting/partial explanations (to be evaluated or improved)
- models of DNA sequences/gene segments or illustrations of sequences of transcription/translation
- data tables or codon charts of gene/allele bases/sequences and corresponding proteins
- graphs showing trends or comparisons among proteins/genes/alleles
- scientific text/descriptions/examples of relationships between DNA and protein structures

Possible contexts:

- simulations/models/descriptions illustrating the role of DNA in specialized cells/specialization of cells
- real-world conceptual translation examples showing the structure of DNA determining the structure of proteins produced through transcription/translation processes
- investigations/research data demonstrating the causative relationship between particular genes and particular proteins (but avoid assessing knowledge of specific protein functions per content limits)

Content and evidence to be included: examples/data that allow students to identify and/or infer evidence that DNA is the instructional code that determines the formation of amino acids that comprise proteins and control life functions

Types of student responses that need to be supported: explaining with evidence and reasoning; supporting explanations based on valid and reliable evidence obtained from a variety of sources for how DNA directs protein formation and therefore controls cell specialization and function

Allowable Item Types:

- MC
- TEI

Model Item Descriptions for B.LS1.1:

#	Item Type	Model Stem (Items ask students to...)	Response Characteristics*
1	MC	<p>Explain cause-effect relationships or relationships between structures/components in a protein synthesis example.</p> <p>[Which statement explains the relationship between genes and hemoglobin proteins?]</p>	<p>Key may focus on genes containing the nucleotide sequences that determine the protein structure versus containing parts that are used to build the protein, activating parts of the protein, or breaking down to produce the protein.</p> <p>Distractors may include statements that do not sufficiently explain, statements that explain alternate phenomena, or statements lacking critical conceptual connections.</p>
2	MC	<p>Explain why different specialized cells have different activated sections of DNA.</p>	<p>Key may focus on different cells needing to make different proteins to carry out different functions or on different cells carrying out different functions, depending on context.</p> <p>Distractors may include statements explaining reasoning for other outcomes of protein synthesis or functions of DNA, or on erroneous explanations for specialization.</p>
3	MC	<p>Select the explanation for the mechanism of DNA coding for a protein that applies to a particular example of protein synthesis.</p> <p>[Which statement best explains how nuclear DNA enables red blood cells to produce the hemoglobin protein?]</p>	<p>Slightly more specific, mechanism/cellular-specific options should be used, as compared with model stem #1 (without getting into biochemistry, per the assessment boundary).</p> <p>Distractors may include statements applying to alternate cellular/genetic mechanisms and/or statements about proteins unrelated to DNA coding.</p>
4	MC	<p>Identify the evidence that supports a given explanation for how the DNA/gene sequence determines the type of protein(s) that are synthesized in these specialized cells.</p> <p>[Which result of the investigation supports the student's explanation for why mutated pancreas cells did not produce insulin?]</p>	<p>Strong evidence might include DNA mutations resulting in a lack of a protein or incorrect protein production, effect of drug/pathogen blockers that prevent steps in the synthesis process, presence of translation/transcription-enabling enzymes that increase the rate of protein synthesis, etc.</p> <p>Distractors may include data that do not provide sufficient/valid evidence or data related to other cellular/genetic processes.</p>
5	TEI	<p>Sort the evidence that supports a given explanation for how the DNA/gene sequence determines the type of protein(s) that are synthesized in these specialized cells.</p> <p>[Drag evidence statements to support event sequences or connect cause and effect.]</p>	<p>Drag-drop interaction.</p> <p>Correct responses show fully correct sort/selection/placement.</p> <p>Partial credit would be given for a subset of correct responses.</p>

#	Item Type	Model Stem (Items ask students to...)	Response Characteristics*
6	MC	Describe the reasoning that connects the evidence of protein synthesis to DNA control of the process(es).	Reasoning might relate to evidence for the valid/actual steps in the process versus steps that don't involve the DNA control process, such as evidence for the roles of molecules during transcription/translation/synthesis as opposed to cell reproduction, respiration, mutation, etc. Distractors may include statements including invalid/unsupported reasoning or reasoning for alternate phenomena.
7	MC	Identify which statement/clarification will best improve the explanation for protein synthesis in this example.	Distractors may include information/data/trivial statements that do not provide an improved explanation.
8	MC	Explain how protein synthesis in these various types of body cells enables the organism to survive.	Distractors may include roles of protein not related to specialization of cells or organism survival.
9	MC	Identify which explanation is supported by the evidence in this example of how specialized cells function in the body.	Distractors may include incomplete or incorrect descriptions/explanations.

Student Misconceptions:

*Response options can make use of Student Misconceptions (examples of scientifically incorrect assumptions) related to this performance expectation; references to misconceptions are listed below:

- Amino acids are the subunits that make up DNA.
- Only animals have DNA; plants and mushrooms do not have DNA.
- The information in the DNA molecules of an organism does not affect the functions of an organism's cells.
- Each DNA molecule is made up of more than one chromosome.
- Each chromosome is made up of more than one DNA molecule.
- Genes do not contain hereditary/genetic information.
- Genes are sequences of amino acids.
- Genes are proteins.

From www.carolina.com/teacher-resources/Interactive/5-common-misconceptions-in-genetics/tr10631.tr:

- Students confuse genetic terms such as chromosomes, genes, and alleles and do not understand the difference between them.

Sample Cluster for B.LS1.1:

Use the information to answer the following questions.

Students learned some information about red blood cells:

- Red blood cells carry oxygen through the bloodstream to all cells of the body.
- Red blood cells use the protein hemoglobin to carry oxygen. Hemoglobin binds and carries oxygen molecules.
- Hemoglobin normally forms a ring-shaped molecule.
- A mutation in the DNA of the hemoglobin gene produces clumped hemoglobin molecules that can reduce oxygen transport.

The students wondered exactly how the DNA mutation causes changes in the hemoglobin. The students found a diagram comparing what happens in cells with and without the DNA mutation. The diagram shows only a small part of the DNA sequence of the hemoglobin gene.

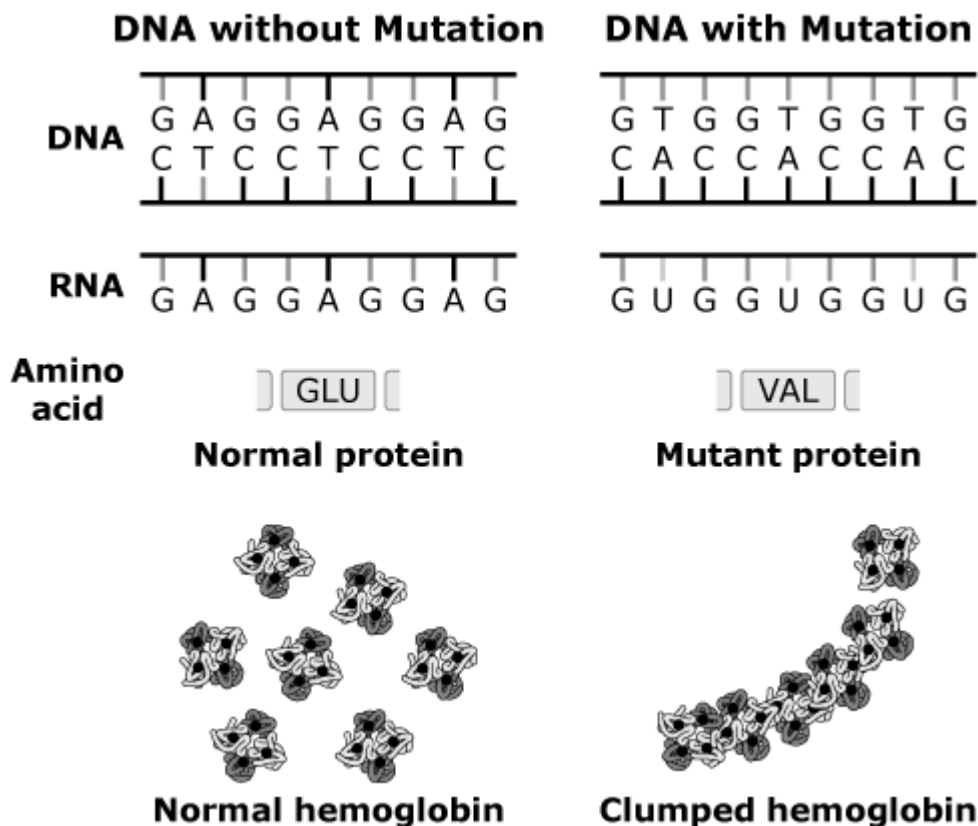

(Items on the following pages)

1 Which statement explains the relationship between DNA and the hemoglobin in red blood cells?

- A** The DNA sequence mutates to allow the hemoglobin to carry oxygen.
- B** The DNA sequence folds at the proper location to shape the hemoglobin.
- C** The DNA sequence is built from the RNA determined by the hemoglobin.
- D** The DNA sequence encodes the amino acid sequence that forms the hemoglobin.

Standard: Construct an explanation based on evidence for how the structure of DNA determines the structure of proteins, which carry out the essential functions of life through systems of specialized cells.

Cognitive Complexity:

SEP: Med

DCI: Med

CCC: N/A

Overall Cognitive Complexity: Moderate Support

Distractor Rationale:

- A. The student may think that the mutation allows hemoglobin to carry oxygen.
- B. The student may think that DNA folds instead of the protein to shape the hemoglobin molecule.
- C. The student may have a reverse understanding of protein production.
- D. Correct. It is the DNA sequence that encodes the sequence of hemoglobin, a protein.**

2 Which statement best explains how RNA supports the production of hemoglobin proteins?

- A** Mutations in the structure of the protein cause changes in the RNA sequences.
- B** RNA sequences from the same chromosomes produce identical protein structures.
- C** RNA sequences direct the correct order of amino acids that join to form the protein.
- D** Blood type determines which sequences become RNA, amino acids, and hemoglobin proteins.

Standard: Construct an explanation based on evidence for how the structure of DNA determines the structure of proteins, which carry out the essential functions of life through systems of specialized cells.

Cognitive Complexity:

SEP: Med

DCI: Med

CCC: N/A

Overall Cognitive Complexity: Moderate Support

Distractor Rationale:

- A. The student may think that proteins will have an effect on the RNA.
- B. The student may not understand the relationship between chromosomes and genes.
- C. **Correct. RNA is translated into an amino acid sequence.**
- D. The student may think that the phenotype determines how the protein is built, rather than the reverse.

3 The information about hemoglobin production can be used as evidence to support which inference about hemoglobin gene expression?

- A** Mutations in the hemoglobin gene may change its function in the body.
- B** Mutations in the hemoglobin gene will not change the amount of hemoglobin produced.
- C** Production of mutant hemoglobin may lead to mutations in other genes.
- D** Production of mutant hemoglobin will not lead to changes in amount of hemoglobin produced.

Standard: Construct an explanation based on evidence for how the structure of DNA determines the structure of proteins, which carry out the essential functions of life through systems of specialized cells.

Cognitive Complexity:

SEP: Med

DCI: Med

CCC: Med

Overall Cognitive Complexity: Low Support

Distractor Rationale:

- A. Correct. Mutations can result in different amino acid sequences which can change protein function.**
- B. The student may think that the information supports the idea that the mutation changes the quantity of protein production.
- C. The student may think that mutations are infections to other genes.
- D. The student may think that the information supports the idea that producing a mutated protein changes the quantity of protein production.

From Molecules to Organisms: Structure and Processes: B.LS1.2

back to “Item Specifications by Performance Expectation”

B.LS1.2. Develop and use a model to illustrate the hierarchical organization of interacting systems that provide specific functions within multicellular organisms.

OAS-S Clarification Statement:

Emphasis is on developing a model in which relevant parts (e.g., an organ system, organs, and their component tissues) and processes (e.g., transport of fluids, motion) of body systems in multicellular organisms are identified and described. Models should then be used to illustrate how relevant parts within a system interact and how systems interact with one another to provide specific functions in multicellular organisms.

OAS-S Assessment Boundary:

Assessment does not include interactions and functions at the molecular or chemical reaction level and is limited to two systems interacting at a time.

Science & Engineering Practice:

Developing and Using Models

- Develop, revise, and/or use a model based on evidence to illustrate and/or predict the relationships between systems or between components of a system.

Disciplinary Core Idea:

Structure and Function

- Multicellular organisms have a hierarchical structural organization in which any one system is made up of numerous parts and is itself a component of the next level.

Crosscutting Concept:

Systems and System Models

- Models (e.g., physical, mathematical, computer models) can be used to simulate systems and interactions—including energy, matter, and information flows—within and between systems at different scales.

In Lay Terms:

Students should be able to use the model to analyze or predict how two systems interact to provide specific functions.

Students should be able to create or analyze models that show the structural organization of multicellular organisms: Cells are the smallest unit of life. Cells make up tissues. Tissues make up organs. Organs make up organ systems. Organ systems make up multicellular organisms.

Cluster Clarifications:

- Interactions and relationships that students need to represent, describe, and analyze in the model include (1) structure-function relationships in the system, and (2) the interdependence of body system functions.
- In order to address the SEP and CCC, when students develop a model, they are expected to construct a model from evidence/data, complete or revise a model, or choose the best model to illustrate a given phenomenon. When students use a model, they interact with an already complete model. When students develop and use a model, they are expected to construct a model from evidence/data, complete a model or choose the best model to illustrate a given concept in some items. In other items they interact with the portions of the model that are already complete. A “develop and use” cluster must contain both types of items. A physical demonstration of a phenomenon is not a model as it does not differ from the reality it represents (in materials, scale, etc.).
- Students should not be expected to have knowledge of function of specific body systems. Information should be provided in order for students to analyze interdependence of systems.

From Molecules to Organisms: Structure and Processes: B.LS1.2

Cluster Stimulus Attributes:

Typical stimulus elements:

- models (complete or partial) of cells, tissues, organs, organ systems, organisms. Relevant components that students need to include in the model are system parts (e.g., cell, tissue, organ, organ system) and any necessary functions/processes.
- models comparing organizational levels at different scales
- diagrams/picture/text description of combinations of organizational levels
- models can show the function of two systems working together

Possible contexts:

- differentiation between levels of structural organization using provided models
- comparisons of organization levels from a model organism to another organism
- constructions of models to illustrate hierarchal relationships and functions of different parts within a body system and interactions between two body systems

Content and evidence to be included: models and/or information about hierarchical structural organization

Types of student responses that need to be supported: constructing and revising and/or using models to identify and show different levels of organization and their influence/contribution to body function

Allowable Item Types:

- MC
- TEI

Model Item Descriptions for B.LS1.2:

#	Item Type	Model Stem (Items ask students to...)	Response Characteristics*
1	MC	Identify the model that shows the correct labeling of cells, tissues, organs, and/or organ systems.	Distractors may include models with incorrect organization/labeling.
2	MC	Identify the level of organization that includes each individual unit OR the groups of cells/tissues/organs shown in the model/diagram. [Which level of organization is represented by the tendon in the muscle diagram?]	Key may focus on a particular level of organization apparent in the model. Distractors may include levels of organization above and below or physiological units other than organizational levels.
3	TE	Arrange/locate the structures to show the correct levels of organization.	Drag-drop or hot-spot interaction. A minimum of three and a maximum of four correct associations should be used. Correct responses show all required associations/locations. Partial credit would be given for a subset of correct responses.
4	TE	Label a model of a complex organism to indicate the levels of organization present. [Label the structures/levels of organization in the organism (by selecting the correct drop-down option or dragging labels).]	Drag-drop or drop-down interaction. A minimum of three labels should be required. Correct responses show all labels accurately placed/selected. Partial credit would be awarded for a subset of correct responses.
5	MC	Identify the description that best fits the component of the model indicated. [Which statement best describes the part of the model that includes the optic nerve?]	Key may focus on structural physiology, the component, or the correct organizational level. Distractors may include descriptions of other structural components within the system or structural components of other systems per common misconceptions.
6	MC	Identify the organizational level of a modeled structure. [Which term best describes the tendons and ligaments of the arm structure?]	Distractors may include incorrect organizational levels.
7	MC	Describe the purpose/system of the organizational hierarchy in the model. [Which statement best describes how this model is organized?] [Which system of classification applies to this model?]	Key may focus on describing the hierarchic nature of the model's components. Distractors may include misinterpretations/misconceptions of the model and/or its components, other common features of the model, or levels not shown in the model.

#	Item Type	Model Stem (Items ask students to...)	Response Characteristics*
8	MC	Describe structural relationships between hierarchical levels or components in a given model.	Key may focus on describing positions/functioning of organizational parts that support a higher level of organization or component smaller parts of an organism, organ system, organ, or tissue. Distractors may include descriptions of structural relationships not related to the model or model characteristics not related to structural organization.
9	MC	Describe the interactions/relationships among components of the model. [How do the stomata cells relate to the various leaf tissues?]	Question and key may focus on different levels to which indicated components belong and on structure and/or function of parts of a higher structural level. Distractors may include misinterpretations/misconceptions about the relationships in the model and the way different structural levels work together.
10	MC	Complete/modify the model to demonstrate an underlying concept about the hierarchical organization of multicellular organisms.	Key may focus on missing elements of the model that provide reasoning for classification of components due to structure, common/differentiated function, position, etc. Distractors may include components associated or not associated with the model but not involved in the underlying concept of the model.
11	MC	Describe one thing the model shows about body/body system/organ system structure or function.	Key could be very general (idea of hierarchical organization) or more specific (one aspect of hierarchical organization). Distractors may include statements that describe aspects of another level or system.

Student Misconceptions:

*Response options can make use of Student Misconceptions (examples of scientifically incorrect assumptions) related to this performance expectation; references to misconceptions are listed below:

- Cells are not organized into the body structures of the organism they are part of.
- Organ systems (and their parts) act independently of each other.

Students may also believe the following:

- Tissues and organs are “overgrown” cells.
- Organs are internal structures only.
- Cells have organs and tissues (instead of organelles and structural components).

From Molecules to Organisms: Structure and Processes: B.LS1.3

back to “Item Specifications by Performance Expectation”

B.LS1.3. Plan and conduct an investigation to provide evidence of the importance of maintaining homeostasis in living organisms.

OAS-S Clarification Statement:

A state of homeostasis (stability) must be maintained for organisms to remain alive and functional even as external conditions change within some range. Examples of investigations could include heart rate response to exercise, stomate response to moisture and temperature, root development in response to water levels, and cell response to hypertonic and hypotonic environments.

OAS-S Assessment Boundary:

Assessment does not include the cellular processes involved in the feedback mechanism.

Science & Engineering Practice:	Disciplinary Core Idea:	Crosscutting Concept:
Planning and Conducting Investigations <ul style="list-style-type: none">Plan and conduct an investigation individually and collaboratively to produce data to serve as the basis for evidence.	Structure and Function <ul style="list-style-type: none">Feedback mechanisms maintain a living system’s internal conditions within certain limits and mediate behaviors, allowing it to remain alive and functional even as external conditions change within some range. Outside that range (e.g., at too high or too low external temperature, with too little food or water available) the organism cannot survive.	Stability and Change <ul style="list-style-type: none">Feedback (negative or positive) can stabilize or destabilize a system.

In Lay Terms:

Students should be able to describe ways to design or improve an investigation about the importance of homeostasis. Homeostasis is a process that regulates or balances an organism’s cellular functions as external factors change, allowing the organism to remain alive.

Cluster Clarifications:

- Interactions and relationships that students need to focus on when using body systems as examples for homeostasis should be at the large-scale, conceptual level (heartbeat, shivering, sweating, etc.), and not on the details of the system.

Cluster Stimulus Attributes:

Typical stimulus elements:

- initial observations or question to be investigated
- investigation design and data (to be analyzed/improved)
- lists of materials and tools to use for an investigation

Possible contexts:

- investigations of heat regulation by evaporation of water (perspiration/transpiration)
- research showing weather/climate’s role in humans’ body temperature (electrolyte deficiency sweating, shivering, etc.)
- investigations showing cell response to hyper- and hypotonic environments; investigations or research data regarding cells’ reactions in different solutions, e.g., saltwater vs. freshwater fish
- the fight-or-flight response
- heart rate response to exercise
- investigations or study results of plant stomata’s response to moisture and temperature or root development in response to water levels

From Molecules to Organisms: Structure and Processes: B.LS1.3

Content and evidence to be included: tables/charts/pictures/diagrams containing information to plan an investigation and/or evaluate a given investigation, with a focus on obtaining the necessary evidence for the importance of homeostasis

Types of student responses that need to be supported: describing and justifying procedures, tools, materials, data to collect, and/or a way to revise an investigation

Allowable Item Types:

- MC
- TEI

Model Item Descriptions for B.LS1.3:

#	Item Type	Model Stem (Items ask students to...)	Response Characteristics*
1	MC	Order/describe the steps in an investigation (e.g., of cell response to solutions of different concentrations) in the order that produces the most useful results. [Which procedure should follow step 4 in this investigation?]	Key may incorporate both an understanding of the process steps (observing all trials/control, when to observe) and characteristic results of the phenomenon being investigated. Distractors may include orders or descriptions that focus on the incorrect question/hypothesis, or misconceptions about the mechanism of the phenomenon being investigated.
2	TEI	Arrange the steps/procedures of an investigation [Put the steps of the investigation about osmosis in the correct order.]	Drag-drop interaction. Matching or drop-down menus could also be used to indicate order/sequence. A minimum of four steps should be put in order. Correct responses show accurate sequence of steps. Partial credit would be awarded for a subset of correct steps, based either on number correct or relative sequencing of identified key steps.
3	MC	Predict data/results of an investigation about what the body’s response will be in different external conditions (overall processes of negative and positive feedback mechanisms). [Which result of the respiration investigation would support the hypothesis that a feedback loop includes the circulatory system?]	Key may focus on processes/mechanisms involved in maintaining homeostasis and what data/variables should be observed or measured to evaluate/analyze the process or mechanism. Distractors may include misunderstandings of homeostasis or of the data necessary to support a prediction about homeostasis.
4	MC	Select which variable to measure to gather data about how a body system will respond to an environmental condition. [What measurement will provide data to best help answer the research question?]	Use common body systems (e.g., circulatory, nervous, respiratory, digestive, immune) that respond directly to a stimulus. Distractors may include variables that measure body system responses to other common stimuli, body system characteristics that are not responses to stimuli, or measurements of the stimuli rather than the response.
5	MC	Identify the hypothesis of a described investigation about homeostasis. [Which question/hypothesis is being investigated in this procedure to test cells?]	Key may focus on the dependent variable’s response to the intended change in the independent variable. Distractors may include variables or questions/predictions that do not connect the relevant cause-effect pattern.
6	MC	Based on supplied data/observations, identify the phenomenon being investigated. [Which statement best describes the human body mechanism being investigated by gathering the data in Table 1?]	Distractors may include related phenomena that cannot be investigated with the data or observations supplied.

#	Item Type	Model Stem (Items ask students to...)	Response Characteristics*
7	MC	Describe the data/observations that would support the purpose of an investigation or claim being investigated. [Which of the following observations would provide evidence that a person cannot produce an adequate amount of adrenaline?]	Distractors may include descriptions of related claims that cannot be investigated (or may be only partially investigated) with the data or observations supplied.
8	MC	Describe <i>how</i> data can be used as evidence of the phenomenon being investigated. [Based on the information in the investigation plan, which step in the process shows how the thyroid gland controls metabolism?]	Key may focus on the operative mechanism in a system that maintains homeostasis. Distractors may include process steps/data that do not support a conclusion about the investigated phenomenon.
9	MC	Critique an investigation for inaccuracies, limitations, or flaws in tools, procedures, or expected results considering the question or hypothesis. [Which statement best explains why the data from the table may not be reliable to answer the question being investigated?]	Items should incorporate elements of content misconceptions in addition to consideration of varying degrees of impact of the investigative shortcomings on the results. Distractors may include steps/procedures that do not significantly affect results or conclusions.
10	MC	Explain how to measure relevant properties of the parameter(s) being investigated (e.g., metabolic rates, cell size, time), including units where appropriate. [Which tools and units should students use to measure the response of both the circulatory and respiratory systems in this investigation?] [Which of the following explains how the scientists should measure the effect of cold temperatures on the autonomic nervous system?]	Distractors may include incorrect procedures, correct procedures but incorrect units, units for an incorrect variable, or the use of familiar but incorrect or less useful or accurate tools or methods.
11	MC	Explain how to manipulate or analyze measurements to be collected in an investigation.	Distractors may include manipulations of inappropriate factors, inappropriate calculations or relationships, incorrect selection of measurement criterion, or inappropriate limits of acceptable accuracy/reliability.
12	MC	Describe the investigation plan that will provide the most useful evidence to answer a given question or support/reject a claim related to homeostasis mechanisms. [Which investigation plan should the students use to demonstrate the idea that heart rate changes in response to exercise?]	Distractors may include irrelevant steps or process that will be less useful in providing data to answer the question or support/reject the claim.

#	Item Type	Model Stem (Items ask students to...)	Response Characteristics*
13	MC	<p>Modify an investigation plan (e.g., to improve quality of data) to produce data to support a given claim related to changes in a system that maintains homeostasis in cells or organisms.</p> <p>[Which of the following shows how to modify the investigation/plan/procedure to test whether the different solutions affect cell volume?]</p> <p>[How should the students modify their investigation to increase the validity of their conclusion about water balance inside and outside of cells?]</p>	<p>Distractors may include modifications that will make the data less useful in supporting the claim or will add procedures irrelevant to supporting the claim. This may include increasing the number of trials while introducing uncontrolled variables, limiting uncontrolled variables while also decreasing the number of trials, or increasing the amount of data collected while reducing the number of trials for each factor tested.</p>
14	MC	<p>Identify or justify the independent, dependent, and/or controlled variables in an investigation set up to measure the effect of an external stimulus on body systems.</p> <p>[In this investigation, why is time the independent variable?]</p> <p>[What is one variable the students should control to increase the accuracy of results in this investigation?]</p>	<p>Distractors may include independent and dependent variables as well as variables that may be/are controlled.</p>
15	MC	<p>Explain how the manipulation of one or more tools or procedures would be expected to influence the result of an investigation of homeostasis.</p> <p>[What would taking measurements more often show about the relationship of the dependent variable to homeostasis?]</p>	<p>Key may focus on impacts of changes in procedures or tools on the dependent variable or on the significance of the data relative to the hypothesis.</p> <p>Distractors may include statements that reveal an incorrect understanding of how the procedure influences the results.</p>
16	TEI	<p>Modify a diagram to represent an investigation setup that will test the claim described.</p> <p>[Modify the diagram to show how to test the claim that cell pressure increases in plant cells in hypotonic solutions.]</p>	<p>Drag-drop interaction.</p> <p>Correct responses will show all required associations that modify the diagram as intended.</p> <p>Partial credit would be given for a subset of correct responses.</p>
17	TEI	<p>Given a diagram of a system in homeostasis, decide on types of data, how much data, and the accuracy of data needed to produce reliable measurements of how the system changes in response to an environmental stimuli.</p> <p>[Identify the type of data, how much data, and the accuracy of data needed to provide measurements to support the claim that soil moisture must remain at a minimum level for the plant to maintain homeostasis.]</p>	<p>Drop-down interaction.</p> <p>Include menus placed strategically on labels of the diagram of the system in homeostasis, such that at each point students decide one of the three data dimensions (i.e., type, how much, accuracy).</p> <p>Menus should contain one example of each data dimension (only one correct dimension) plus 1-3 extraneous dimensions.</p> <p>Correct responses will show all selections correctly.</p> <p>Partial credit would be given for a subset of correct responses.</p>

Student Misconceptions:

*Response options can make use of Student Misconceptions (examples of scientifically incorrect assumptions) related to this performance expectation; references to misconceptions are listed below:

- A given experiment can test for the effects of everything that is included in the study, whether these variables are allowed to vary or are held constant.
- A given experiment tests for the effects of ALL related variables, regardless of whether they are allowed to vary or are held constant.
- A given experiment tests for the effect of a variable that remains constant while other variables change.
- It is not important to hold a variable constant in an experimental study if the purpose of the study is not to find out the effect of that variable on the outcome of the study.
- Air is distributed through the body in air tubes.
- Molecules from food are distributed by way of special tubes, not by way of the circulatory system, to the rest of the body.
- Molecules from food enter the digestive tract and pass through the body without entering cells of the body.
- Air is breathed in and out of the body without being absorbed or used in any way.

From Molecules to Organisms: Structure and Processes: B.LS1.4

back to “Item Specifications by Performance Expectation”

B.LS1.4. Use a model to illustrate the role of cellular division (mitosis) and differentiation in producing and maintaining complex organisms.

OAS-S Clarification Statement:

Emphasis is not on the details of each phase of mitosis but on the conceptual understanding that mitosis produces genetically identical cells via DNA replication and cell division and that immature cells may become specialized through differentiation.

OAS-S Assessment Boundary:

Assessment does not include specific gene control mechanisms or rote memorization of the steps of mitosis.

Science & Engineering Practice:

Developing and Using Models

- Develop, revise, and/or use a model based on evidence to illustrate and/or predict the relationships between systems or between components of a system.

Disciplinary Core Idea:

Growth and Development of Organisms

- In multicellular organisms individual cells grow and then divide via a process called mitosis, thereby allowing the organism to grow.
- The organism begins as a single cell (fertilized egg) that divides successively to produce many cells, with each parent cell passing identical genetic material (two variants of each chromosome pair) to both daughter cells.
- Cellular division and differentiation produce and maintain a complex organism, composed of systems of tissues and organs that work together to meet the needs of the whole organism.

Crosscutting Concept:

Systems and System Models

- Models (e.g., physical, mathematical, computer models) can be used to simulate systems and interactions—including energy, matter, and information flows—within and between systems at different scales.

In Lay Terms:

Students should be able to use models to illustrate that in multicellular organisms, individual cells divide to form two identical cells. All multicellular organisms begin as a single cell, which undergoes this process of dividing. Cells undergo mitosis in order to grow, repair, or replace injured or worn-out cells.

Cluster Clarifications:

- Relevant components in the models should include genetic material/chromosome pairs, parent cells and daughter cells, and multicellular tissue/body representations.
- Interactions and relationships that students need to describe and analyze in the model include (1) daughter cells receive identical genetic information from the parent cell, making them genetically identical, (2) differences between cell types within an organism are due to different genes being turned on (differentiation), not different genetic material, and (3) the cell division/mitotic process allows for growth, differentiation, tissue repair, and replacement of dead cells to produce and maintain complex organisms.
- In order to address the SEP and CCC, when students use a model, they interact with an already complete model. Whereas when students develop and use a model, they are expected to construct a model from evidence/data, complete a model or choose the best model to illustrate a given concept in some items. A physical demonstration of a phenomenon is not a model as it does not differ from the reality it represents (in materials, scale, etc.).

From Molecules to Organisms: Structure and Processes: B.LS1.4

Cluster Stimulus Attributes:

Typical stimulus elements:

- pictures/diagrams/models of beginning and ending of mitosis
- text descriptions of the importance of a cell's need to divide and the importance of identical DNA being passed down

Possible contexts:

- evaluating models that show why is it important for different tissues to produce identical cells (with identical DNA)
- evaluating/constructing models to observe how cancer cells and uncontrollable cell division occur
- evaluating the genetic content of parent and daughter cells in mitosis
- modeling the role of mitosis before and after cell differentiation
- explaining how models illustrate the mitotic process or its products

Content and evidence to be included: information (descriptions and/or partial models) about cell division (mitosis and differentiation)

Types of student responses that need to be supported: interpreting a provided model in order to identify and describe the necessary process components and the interaction/relationships among them that accomplish growth, tissue repair, and cell replacement via mitosis and differentiation in organisms

Allowable Item Types:

- MC
- TEI

Model Item Descriptions for B.LS1.4:

#	Item Type	Model Stem (Items ask students to...)	Response Characteristics*
1	MC	<p>Use evidence from the model to explain why cells divide through mitosis/the purpose of the model.</p> <p>[Which statement best explains the purpose of cell mitosis in the diagram?]</p> <p>[Why do cells undergo the process shown in the model?]</p>	<p>Key may focus on one of the purposes of cell division (mitosis) in multicellular organisms (i.e., growth, repair, or replacement of cells in organisms).</p> <p>Distractors may include alternate cell roles/functions in organisms or alternate purposes of the process(es) illustrated in the model, based on misconceptions of the model and/or its components.</p>
2	MC	<p>Identify the impact of uncontrolled cell division that is illustrated by a specific component of the model.</p> <p>[Which statement best describes the importance of the process of cell cycle regulation shown in the model?]</p>	<p>Distractors may include functional descriptions of the components of the model that do not play a role in cell cycle regulation or that pertain to controlled division of cells vs. uncontrolled division.</p>
3	MC	<p>Identify the key process shown in the mitosis model.</p> <p>[Which step in the model shows the process by which organisms replace cells that die?]</p>	<p>Key may focus on model steps/processes relevant to producing genetically identical daughter cells.</p> <p>Distractors may include processes or steps not related to or dependent upon mitotic cell division.</p>
4	MC	<p>Describe the interactions among components of the model related to mitosis.</p> <p>[Based on the information shown in the model, which cell organelle must be transferred exactly to achieve successful mitosis?]</p>	<p>Key may focus on the exact numbers of chromosomes or nuclear material.</p> <p>Distractors may include organelles that are important to cellular function but not to genetic identity.</p>
5	MC	<p>Identify the best model to describe a related phenomenon involving cellular division, based on the initial model.</p> <p>[Based on the students' model, which model demonstrates how a plant leaf cell produces a new leaf cell?]</p>	<p>Key should focus on a model depicting mitosis.</p> <p>Distractors may include models that show additional or insufficient steps/parts/products.</p>
6	MC	<p>Select and explain the model that best fits a set of observations or data illustrating mitosis or cell differentiation.</p> <p>[Which model of plant cells and its explanation best illustrates the rapidly-growing tips of the plant's roots?]</p>	<p>Key may focus on cell morphological changes with explanations related to genetic similarity between parent and daughter cells.</p> <p>Distractors may include models and explanations that do not represent cells undergoing mitosis.</p>
7	MC	<p>Explain how a model demonstrates the scale of the mitosis phenomenon.</p> <p>[Which statement describes how the model differs from the actual process of mitosis in cells?]</p>	<p>Key may focus on the macroscopic nature of the model compared to the microscopic nature of the actual process or discuss duplicity of the model in terms of exponential factors on a diminutive scale.</p> <p>Distractors may include statements related to model components that are similar to the actual process of mitosis.</p>

#	Item Type	Model Stem (Items ask students to...)	Response Characteristics*
8	MC	Relate the accuracy/validity of the mitosis model to supporting evidence. [Which evidence from the data table would support the claim that the mitosis model is accurate?]	Key may focus on the degree of support or extent of the evidence that supports the model claim about mitosis. Distractors may include data that relate to broader processes/relationships but do not support the idea that daughter cells are genetically identical to parent cells.

Student Misconceptions:

*Response options can make use of Student Misconceptions (examples of scientifically incorrect assumptions) related to this performance expectation; references to misconceptions are listed below:

- In the early development of an organism, cells that result from cell division do not grow before dividing again.
- Organisms grow by cell division, but cells do not themselves increase in size or mass.
- In the early development of an organism, cells grow in size but the number of cells remains constant.
- In the early development of an organism, the organism grows in size and mass without cell division or cell growth.
- Chromosomes are divided up at each cell division, such that when a single body cell forms two body cells, the resulting cells each contain fewer chromosomes than the original cell.

Students may also believe the following:

- All cell components are replicated during the process of mitosis.
- Chromosomes separate in random groups during mitosis to produce daughter cells with varying numbers of chromosomes.

From Molecules to Organisms: Structure and Processes: B.LS1.5

back to “Item Specifications by Performance Expectation”

B.LS1.5. Use a model to illustrate how photosynthesis transforms light energy into stored chemical energy.

OAS-S Clarification Statement:

Emphasis is on illustrating inputs and outputs of matter and the transfer and transformation of energy in photosynthesis by plants and other photosynthesizing organisms. Examples of models could include diagrams, chemical equations, or conceptual models developed from investigations.

OAS-S Assessment Boundary:

The assessment should provide evidence of students’ abilities to describe the inputs and outputs of photosynthesis, not the specific biochemical steps (e.g., photosystems, electron transport, and Calvin cycle).

Science & Engineering Practice:

Developing and Using Models

- Develop, revise, and/or use a model based on evidence to illustrate and/or predict the relationships between systems or between components of a system.

Disciplinary Core Idea:

Organization for Matter and Energy Flow in Organisms

- The process of photosynthesis converts light energy to stored chemical energy by converting carbon dioxide plus water into sugars plus released oxygen.

Crosscutting Concept:

Energy and Matter

- Changes of energy and matter in a system can be described in terms of energy and matter flows into, out of, and within that system.

In Lay Terms:

Students should be able to describe and interpret a model showing that photosynthesis uses sunlight, carbon dioxide, and water to make oxygen and sugars. These sugars provide energy for living things.

Cluster Clarifications:

- Relevant components in the models should include light energy, reaction/bond rearrangements (absorbing/releasing energy), carbon dioxide, water, sugar, and oxygen.
- Interactions and relationships that students need to describe and analyze in the model include (1) input-output relationships (carbon dioxide and water produce sugar and oxygen), (2) energy is transformed from light to chemical energy, (3) photosynthesis results in a storage of energy, and (4) photosynthesis transfers matter and energy between the organism and environment.
- In order to address the SEP, when students use a model, they interact with an already complete model. Whereas when students develop and use a model, they are expected to construct a model from evidence/data, complete a model or choose the best model to illustrate a given concept in some items. A physical demonstration of a phenomenon is not a model as it does not differ from the reality it represents (in materials, scale, etc.).

Cluster Stimulus Attributes:

Typical stimulus elements:

- model/picture/diagram/chemical equation of cellular level of photosynthesis (chloroplast) or an entire producer in its habitat
- text descriptions/chemical equations showing the inputs and outputs of photosynthesis
- observed evidence/data (in text, tables, graphs) from investigations of photosynthesis, including data tables evaluating the inputs’ effect on photosynthesis

Possible contexts:

- study of vegetation native to Oklahoma or North America, emphasizing the overall process of photosynthesis
- evaluation of investigations that include different environmental conditions and their effect on the outputs of photosynthesis
- comparison, using evidence, of the different forms of energy found before and after photosynthesis (solar energy vs. chemical energy)
- computer simulations of the photosynthetic process
- counting oxygen bubbles from Elodea leaves underwater and the glowing splint test

From Molecules to Organisms: Structure and Processes: B.LS1.5

Content and evidence to be included: models of photosynthesis (transforming light energy into stored chemical energy); amounts of inputs/outputs of photosynthesis (in models or as data to support models)

Types of student responses that need to be supported: describing and analyzing the components and interactions in a model of photosynthesis in order to explain how photosynthesis transforms light energy into stored chemical energy (i.e., inputs, outputs, and energy transformations)

Allowable Item Types:

- MC
- TEI

Model Item Descriptions for B.LS1.5:

#	Item Type	Model Stem (Items ask students to...)	Response Characteristics*
1	MC	Determine how the outputs of photosynthesis will be affected when variables are changed. [Which evidence shows that sunlight intensity affects the rate of photosynthesis?]	Key may focus on increases or decreases in glucose or oxygen production. Distractors may include controlled variables or factors not relevant to the investigation.
2	MC	Identify/distinguish what model components/ data illustrate the form of energy before (solar/ radiant) or after photosynthesis (chemical/ stored “sugar”). [Based on the model, which statement describes the form of energy stored in plant leaves?]	Key may include sunlight transforming to chemical/electrical (charged electrons) and/or chemical potential energy buildup. Distractors may include illustrations not related to energy, energy forms not related to photosynthesis, or transformations of relevant energy forms outside the process of photosynthesis.
3	MC	Identify/explain how the model shows the changes from input to output (from before to after photosynthesis). [Based on the model, which event during the investigation is evidence that photosynthesis occurred?]	Key may focus on reactants and/or products of photosynthesis corresponding to the given model. Distractors may include non-participating components, energy vs. physical components, or components undergoing processes outside of photosynthesis.
4	MC	Identify the impact of photosynthesis/ respiration on the carbon cycle that is illustrated by a specific component of the model. [Which statement best describes the importance of the process illustrated in the model?]	Distractors may include functional descriptions of the components of the aerobic respiration process that are not high in importance (per the specific cycle or process). Key may focus on the flow or forms of carbon in the photosynthesis/respiration paths.
5	MC	Identify relationships between inputs and outputs of the model. [Based on the model, which statement describes the relationship between photosynthesis and carbon dioxide?] [Based on the model, what can be inferred about the relationship between available sunlight and the amount of glucose produced in algae?]	Key may focus on evidence of a particular input/output component or on proportions or totals of reactants and products. Distractors may include statements describing alternate relationships or misconceptions about functions/processes.
6	MC	Describe the interactions among components of the model related to energy transactions. [Based on the information shown in the model, how is oxygen related to energy storage in plants?]	Key may focus on energy transactions or conversions. Distractors may include descriptions of roles not related to the specified process/function or interactions that occur but are not involved directly in the process.
7	MC	Select and explain the model that best fits a set of observations or data about photosynthesis. [Which model of photosynthesis reactions best fits the data from this experiment, and why?]	Distractors may include models and explanations that do not consider conservation of matter.

#	Item Type	Model Stem (Items ask students to...)	Response Characteristics*
8	MC	Explain <i>how</i> data support a particular model of photosynthesis. [Which statement describes how the data collected in this investigation support the model?]	Distractors may include statements related to data that do not support the model or model components unrelated to the data.

Student Misconceptions:

*Response options can make use of Student Misconceptions (examples of scientifically incorrect assumptions) related to this performance expectation; references to misconceptions are listed below:

- Substances in soil are food for plants.
- Plants have multiple food sources, not just the sugars that they make from water and carbon dioxide.
- Food enters a plant through the roots.
- Plants make sugars from minerals.
- Plants get organic food substances such as starch and sugar or protein from the soil.
- Plants use oxygen [and produce carbon dioxide] during photosynthesis.

From Molecules to Organisms: Structure and Processes: B.LS1.6

back to “Item Specifications by Performance Expectation”

B.LS1.6. Construct and revise an explanation based on evidence for how carbon, hydrogen, and oxygen from sugar molecules may combine with other elements to form amino acids and/or other large carbon-based molecules.

OAS-S Clarification Statement:

Emphasis is on using evidence from models and/or simulations to support explanations for how organisms take in matter and rearrange the atoms in chemical reactions to form amino acids and/or other large carbon-based molecules.

OAS-S Assessment Boundary:

Assessment does not include the details of the specific chemical reactions or identification of macromolecules.

Science & Engineering Practice:

Constructing Explanations

- Use evidence (e.g., measurements, observations, patterns) to construct or support an explanation.

Disciplinary Core Idea:

Organization for Matter and Energy Flow in Organisms

- The sugar molecules thus formed contain carbon, hydrogen, and oxygen: their hydrocarbon backbones are used to make amino acids and other carbon-based molecules that can be assembled into larger molecules (such as proteins or DNA), used for example to form new cells.
- As matter and energy flow through different organizational levels of living systems, chemical elements are recombined in different ways to form different products.

Crosscutting Concept:

Energy and Matter

- Changes of energy and matter in a system can be described in terms of energy and matter flows into, out of, and within that system.

In Lay Terms:

Students should be able to use the SEP to explain how molecules combine, break apart, and recombine to form necessary compounds for life. These include sugars, amino acids, carbohydrates, and proteins. The process of creating these compounds is done by plants and animals at a cellular level.

Cluster Clarifications: (none)

Cluster Stimulus Attributes:

Typical stimulus elements:

- models and diagrams
- data tables and graphs
- scientific reports or summaries

Possible contexts:

- examples of biological products, food, digestion
- investigations or models of how basic molecules are used to build more complex molecules and cellular constituents (cell walls, membranes, organelles, etc.)

Content and evidence to be included: information to use as evidence of the relationship of carbon, hydrogen, and oxygen in formation of essential cellular molecules

Types of student responses that need to be supported: constructing explanations, including analyzing the evidence for the explanation

Allowable Item Types:

- MC
- TEI

Model Item Descriptions for B.LS1.6:

#	Item Type	Model Stem (Items ask students to...)	Response Characteristics*
1	MC	Identify the simple component molecule that makes up a more complex component or vice versa.	Examples of synthesis/decomposition of biological hydrocarbons (proteins, fats, starches) are used. Component molecules may include amino acids, glycerol, fatty acids, simple sugars, and protein subunits chains. Note that students are not responsible for identifying macromolecules. Distractors may include other biological molecules not representative in the example given.
2	MC	Develop an explanation (text-based) for the breakdown or formation of biological carbon and hydrogen compounds. [Which explanation for how carbon atoms form the backbone of most organic molecules is supported by the data?]	Items should present data evidence from digestion of food, cellular respiration, the array of carbohydrate molecules in an organism, or similar common examples. Distractors may include explanations of alternate mechanisms or alternate functions/molecular applications of carbon atoms.
3	MC	Explain through a model or models the breakdown or formation of biological carbon and hydrogen compounds. [Based on the research findings, which model shows the basic way in which starches are formed?]	Models may be atomic/molecular, conceptual, or mathematical. Distractors may include models with unrelated biological molecules or models with processes not related to the targeted process.
4	MC	Use the model/diagram to explain how chemical elements are passed through food in biological systems. [According to the model, what is the source of hydrogen in most organisms?]	Key may focus on building-block molecules for more complex molecules or the passage of a particular element via several different compounds. Distractors may include sources of the element not contained in food, the destination of other elements, and/or other destinations for C, H, O.
5	TEI	Construct or complete a model/diagram to explain how chemical elements are recombined in different ways to form different products related to cellular components. [Show which compounds are produced in each step of the digestive process (by dragging the elements and/or compounds into the product areas).]	Drag-drop interaction. Could also be done using drop-down or match interaction. Items should address the nature or interaction of elements and compounds that cannot be easily illustrated in static examples or are too complex to explain in a multiple-choice item. Correct responses show all products requested. Partial credit would be awarded for a subset of correct responses.
6	MC	Describe or explain relationships (cause-effect, or other) in the synthesis or decomposition of C-H-O compounds. [Which statement explains the relationship between carbon dioxide and starch molecules?]	Key may focus on processes or steps in the cause-effect chain of events. Distractors may include statements that do not sufficiently explain, statements that explain alternate phenomena, or statements lacking critical conceptual connections.

#	Item Type	Model Stem (Items ask students to...)	Response Characteristics*
7	MC	Develop an explanation for a real-world/macro observation or phenomenon based on the evidence. [Which statement best explains why the starchy cracker tasted sweet after 10 minutes?]	Key may focus on explanation of the macro observation or phenomenon based on interpreting the molecule synthesis or breakdown occurring. Distractors include statements explaining reasoning for other outcomes or erroneous explanations for the observation or phenomenon.
8	MC	Identify/use evidence to support an explanation of relationships among components of a C-H-O driven system. [What evidence supports the students' explanation for how energy is related to food molecules?]	Key may include evidence such as production of carbon dioxide gas, calorimeter data, proportions of complex vs. simple molecules in organisms, etc. Distractors may include data that do not provide sufficient/valid evidence or data related to other cellular/genetic processes.
9	MC	Connect reasoning to the evidence for the origin or production of C-H-O compounds in biological systems (i.e., <i>how</i> the data support the particular explanation). [Which statement best describes the reason high levels of CO ₂ gas are produced by yeasts in bread dough?]	Key may focus on a biological process or product that illustrates the flow of carbon through or between organisms. Distractors may include statements including invalid/unsupported reasoning or reasoning for alternate phenomena, incorrect data interpretations, and/or misconceptions.
10	MC	Provide evidence-based clarification/additional data to improve an explanation of a C-H-O process. [Based on the evidence, which additional statement/clarification will best improve the explanation for the transfer of carbon in the plant?]	Distractors may include information/data/trivial statements that do not provide an improved explanation.
11	TEI	Build an explanatory model/flow chart to explain how C, H, or O moves into and through a cell. [Put the process steps in order to show how oxygen moves through cells.]	Drag-drop interaction to reorder. May present item with 4-6 descriptions of processes/compounds as options to order/drag. Students may have to order options given, or choose which options to place into a partially completed sequence provided. Correct responses show an accurate sequence, completed as required. Partial credit would be given for a subset of correct responses/sequencing.

Student Misconceptions:

*Response options can make use of Student Misconceptions (examples of scientifically incorrect assumptions) related to this performance expectation; references to misconceptions are listed below:

- Food is a source of energy but not a source of building materials.
- Food is a source of building materials, but not a source of energy.
- Food is any material (water, air, minerals, etc.) that organisms take in from their environment.
- Oxygen supplies energy for animals.
- Plants get organic food substances such as starch and sugar from the soil.
- Plants make sugar from minerals or minerals and water.
- Carbon dioxide is food for plants.
- Water is food for plants.
- Plants use oxygen during photosynthesis.

From Molecules to Organisms: Structure and Processes: B.LS1.7

back to “Item Specifications by Performance Expectation”

B.LS1.7. Use a model to illustrate that cellular respiration is a chemical process whereby the bonds of food molecules and oxygen molecules are broken and the bonds in new compounds are formed resulting in a net transfer of energy.

OAS-S Clarification Statement:

Emphasis is on the conceptual understanding of the inputs and outputs of the process of cellular respiration. Examples of models could include diagrams, chemical equations, or conceptual models developed from investigations.

OAS-S Assessment Boundary:

Assessment should not include identification of the steps or specific processes involved in cellular respiration (e.g., glycolysis and Krebs’s Cycle).

Science & Engineering Practice:

Developing and Using Models

- Develop, revise, and/or use a model based on evidence to illustrate and/or predict the relationships between systems or between components of a system.

Disciplinary Core Idea:

Organization for Matter and Energy Flow in Organisms

- As matter and energy flow through different organizational levels of living systems, chemical elements are recombined in different ways to form different products.
- As a result of these chemical reactions, energy is transferred from one system of interacting molecules to another.
- Cellular respiration is a chemical process in which the bonds of food molecules and oxygen molecules are broken and new compounds are formed that can transport energy to muscles.
- Cellular respiration also releases the energy needed to maintain body temperature despite ongoing energy transfer to the surrounding environment.

Crosscutting Concept:

Energy and Matter

- Energy cannot be created or destroyed—it only moves between one place and another place, between objects and/or fields, or between systems.

In Lay Terms:

Students should be able to analyze and explain models illustrating the process of cellular respiration (making energy from sugar in plants and animals) as a process that provides energy for life on Earth.

From Molecules to Organisms: Structure and Processes: B.LS1.7

Cluster Clarifications:

- To address the CCC, stimuli and items should focus on how/why energy is stored, transferred, or released with respect to cellular respiration.
- Relevant components in the models should include food molecules (sugars), oxygen, water, carbon dioxide, reaction/bond rearrangements, and energy.
- Interactions and relationships that students need to describe and analyze include (1) sugar and oxygen produce carbon dioxide and water in cellular respiration, (2) cellular respiration releases energy (due to bond energies/bond rearrangement), (3) matter and energy are conserved during cellular respiration (bonds break and new bonds form and energy is released, but matter and energy are neither created nor destroyed), and (4) body cells can use energy from cellular respiration to sustain life processes.
- Note that conservation of matter is a critical component of this PE and must be addressed in the cluster.
- In order to address the SEP, when students use a model, they interact with an already complete model. Whereas when students develop and use a model, they are expected to construct a model from evidence/data, complete a model or choose the best model to illustrate a given concept in some items. A physical demonstration of a phenomenon is not a model as it does not differ from the reality it represents (in materials, scale, etc.).

Cluster Stimulus Attributes:

Typical stimulus elements:

- models/pictures/diagrams/chemical equations of cellular respiration (mitochondria) or an entire producer/consumer in its habitat
- text descriptions/chemical equations showing the inputs and outputs of cellular respiration
- diagrams of experimental setups and results/data from investigations involving cellular respiration

Possible contexts:

- investigations that include different environmental conditions and their effect on the outputs of cellular respiration
- evaluations of simulations/models/diagrams providing an explanation from evidence for the different forms of energy found before and after cellular respiration [chemical energy (glucose) vs. chemical energy (ATP)]
- text/diagram examples of the role of cellular respiration in maintaining body temperature despite surrounding environment
- investigations demonstrating the respiration process

Content and evidence to be included: experimental results/observations containing simulations, illustrations, model components or inputs/outputs, along with text describing processes or results

Types of student responses that need to be supported: describing or analyzing the components and relationships of a model that illustrates the chemical process of cellular respiration, with emphasis on the breaking and formation of chemical bonds resulting in a release of energy and formation of new molecules as atoms are rearranged

Allowable Item Types:

- MC
- TEI

Model Item Descriptions for B.LS1.7:

#	Item Type	Model Stem (Items ask students to...)	Response Characteristics*
1	MC	Evaluate a model of respiration to identify/ describe the inputs/outputs of cellular respiration in terms of their energy roles. [According to the model, which component stores chemical energy for release during cellular respiration?]	Key may focus on sugar as the source of chemical energy, oxygen/sugar as the molecule that reacts to release energy, or carbon dioxide/ water as the product of energy release. Distractors may include model components unrelated to the transfer of energy or energy-storing processes not included in the model.
2	MC	Determine from the model how the outputs of cellular respiration will be affected when respiration variables are changed. [Based on the model, how will a low-oxygen environment affect energy production in cells?]	Key may focus on the contrast between aerobic and anaerobic processes, differentiation of total ATP produced, or output evidence indicating a significant difference in energy consumed in aerobic versus anaerobic conditions. Distractors may include misconceptions about the sources of energy, how energy is converted during respiration, or the process by which respiration occurs in a low-oxygen environment.
3	MC	Infer from the model the form of energy before (stored) or after cellular respiration (released). [Based on the model, which statement best describes the energy produced during respiration?]	Options may require students to differentiate compounds or forms/amounts of energy associated with the stage indicated.
4	MC	Explain how a (given) respiration model supports or fits observations/experimental results, or vice versa. [Which explanation for the results of the (respiration) experiment is best supported by the model and why?] [How do observations of the different forms of gas before and after cellular respiration provide evidence for the model of respiration the students created?]	Explanatory statements may include inputs/ outputs or component comparisons and reasoning based on energy transformation(s). Distractors may include plausible explanations that do not directly provide evidence for respiration.
5	MC	Analyze the model to identify the impact of cellular respiration on the availability of energy. [Which statement best describes how a decrease in the amount of available food affects the amount of energy available to an organism?]	Distractors may include functional descriptions of the components of the aerobic respiration process that are not high in importance (per the specific cycle or process).
6	MC	Describe the purpose of a respiration model. [Which statement best describes why this model is important to understanding how organisms function?]	Key may focus on how respiration supplies energy needed by organisms or why energy is needed or used by organisms. Distractors may include misinterpretations/ misconceptions of the model and/or its components.

#	Item Type	Model Stem (Items ask students to...)	Response Characteristics*
7	MC	Identify relationships between inputs and outputs of a respiration model. [Based on the model, which statement describes the relationship between respiration and carbon dioxide?] [Which inference about the relationship between glucose and energy is supported by the model?]	Key may focus on component and energy relationships. Distractors may include statements describing alternate relationships or misconceptions about functions/processes.
8	MC	Describe the interactions among components of the model related to energy transactions. [Based on the model, how is the amount of glucose related to oxygen consumption in the two examples?]	Distractors may include descriptions of roles not related to the specified process/function or interactions that occur but are not involved directly in the process.
9	MC	Select and explain the model that best fits a set of observations or data. [Which model of carbon atom transformations and its explanation best fit the data from this experiment?]	Distractors may include models and explanations that do not appropriately address respiration molecules and processes.
10	MC	Relate a model to supporting evidence. [Which evidence from the data table would support the claim that the respiration model is accurate?]	Key may focus on energy evidence or component evidence that supports energy transformations. Distractors may include data that relate to broader respiration processes/relationships but do not support the claim of accuracy.

Student Misconceptions:

*Response options can make use of Student Misconceptions (examples of scientifically incorrect assumptions) related to this performance expectation; references to misconceptions are listed below:

- Animals cannot store molecules from food in their bodies.
- Molecules from food are not stored in the fat tissue of animals.
- Plants cannot store molecules from food in their body structures.
- Carbon dioxide is food for plants.
- Food is a source of building materials, but not a source of energy.
- Food is any material (water, air, minerals, etc.) that organisms take in from their environment.
- Oxygen supplies energy for animals.
- Energy can be created.
- Energy can be destroyed.
- One form of energy cannot be transformed into another form of energy (e.g., chemical energy cannot be converted to kinetic energy).
- Energy cannot be transferred from one object to another.

Ecosystems: Interactions, Energy, and Dynamics: B.LS2.1

back to “Item Specifications by Performance Expectation”

B.LS2.1. Use mathematical and/or computational representations to support explanations of factors that affect carrying capacity of ecosystems at different scales.

OAS-S Clarification Statement:

Emphasis is on quantitative analysis and comparison of the relationships among interdependent factors including boundaries, resources, climate and competition. Examples of mathematical comparisons could include graphs, charts, histograms, or population changes gathered from simulations or historical data sets.

OAS-S Assessment Boundary:

Assessment does not include deriving mathematical equations to make comparisons.

Science & Engineering Practice:

Using Mathematics and Computational Thinking

- Use mathematical, computational, and/or algorithmic representations of phenomena to describe and/or support claims and/or explanations.

Disciplinary Core Idea:

Interdependent Relationships in Ecosystems

- Ecosystems have carrying capacities, which are limits to the numbers of organisms and populations they can support. These limits result from such factors as the availability of living and non-living resources and from challenges such as predation, competition, and disease.
- Organisms would have the capacity to produce populations of great size were it not for the fact that environments and resources are finite. This fundamental tension affects the abundance (number of individuals) of species in any given ecosystem.

Crosscutting Concept:

Scale, Proportion, and Quantity

- The significance of a phenomenon is dependent on the scale, proportion, and quantity at which it occurs.

In Lay Terms:

Students should be able to use numerical data, charts, and graphs to draw conclusions about the influence of various living and non-living factors on population sizes and the ability of ecosystems to support sustainable populations.

Cluster Clarifications:

- Examples of ecosystems and organisms outside of Oklahoma can be utilized, but their definitive characteristics should be clearly explained.
- Food webs, energy pyramids, and biomass pyramids are considered mathematical expressions.
- Carrying capacity is a characteristic of habitats/ecosystems and not of a species.
- K may be defined as carrying capacity.
- Population graph shapes may be described with the terms J-shaped, S-shaped, exponential, and logistic.
- Graphs should not be dual-axis graphs; use two separate graphs instead.

Ecosystems: Interactions, Energy, and Dynamics: B.LS2.1

Cluster Stimulus Attributes:

Typical stimulus elements:

- graphs, histograms, charts/tables
- descriptions of simulations and the quantitative data generated
- other mathematical representations of relationships, populations, or resources changes provided in given examples or data sets

Possible contexts:

- real-world research revealing trends, averages, and data that are relevant to carrying capacity and population dynamics in a given environment
- graphical comparisons of historical population-related data for a species or group of interrelated species in the context of limiting resources
- graphical or textual representations of predator/prey, mutualistic, parasitic, or commensal relationships
- student or scientific claims of what can limit population size or how populations are affected given data or observations in specific examples

Content and evidence to be included: mathematical data about population sizes, including data or text about factors affecting the ecosystem's ability to sustain those populations

Types of student responses that need to be supported: describing conclusions about what the mathematical data show about populations/carrying capacity, with the conclusions related to what/how factors affect the carrying capacity

Allowable Item Types:

- MC
- TEI

Model Item Descriptions for B.LS2.1:

#	Item Type	Model Stem (Items ask students to...)	Response Characteristics*
1	MC	Select the graphical representation for population size, growth, or capacity based on the data provided. [Which graph best represents the type of growth experienced by the producer population?]	Key may focus on logistic vs. exponential growth or trend differences. Distractors may include graphs depicting other population growth trends.
2	MC	State conclusions about population growth, reproductive rate, survival rate, etc. based on the graphs/data provided. [Which statement about the reproduction rate of bacteria compared to the reproduction rate of sharks is supported by the population data?]	Key may focus on trends or patterns in population curves/comparisons. Distractors may include unrelated or unsupported statements.
3	MC	Select the graph that shows the correct relationship between the dependent and independent variable based on the provided population and environmental data. [Which graph shows how the two pollinator insect populations will most likely respond to a drought that reduces the populations of flowering plants?]	Key should focus on the graph that correctly displays the relationship between independent and dependent variables. Distractors may include graphs depicting inaccurate/incorrect population response curves.
4	MC	Analyze environmental factors and a population change data to evaluate <i>how</i> the data do or do not support the given explanation for the change. [Which statement best describes how the data relate to the student's claim about the population change?] [How do the data on the limiting factors in the pond ecosystem support the student's explanation of the changes in bluegill population density?]	Key should focus on the data and reasoning about the causative factors limiting the population, as indicated in the explanation. Distractors may include explanations of factors that are not limiting or limiting factors that are not supporting.
5	MC	Identify data to support explanations of birth, death, immigration, emigration, disease, competition, predation, etc. as causative factors in determining carrying capacity. [What data support the explanation of disease as a causative factor in the declining pinion pine tree population?]	Key may focus on a clear relationship between one of the causative factors and a responding trend in the population. Distractors may include data/factors of lesser or no impact on the population.
6	MC	Compare the relative degree of influence on a population of several causative factors to determine which explanation is best supported. [Based on the data, which statement best describes how weather factors most impacted the change in deer population?]	Key may focus on a dominant determining factor or a factor that has a direct rather than indirect impact on the population. Distractors may include statements about factors that are subordinate to a main factor or that incorrectly describe impacts of factors.

#	Item Type	Model Stem (Items ask students to...)	Response Characteristics*
7	MC	Make predictions about carrying capacity and/or population change using the math representation. [Which prediction about the effect of temperature on the coral population is supported by the data?]	Distractors may include cause-and-effect statements that are not supported by the data.
8	MC	Using data, determine which explanation most accurately compares the impact of a factor observed on a micro scale to the same factor observed on a macro scale (on populations of the same species in the same ecosystem).	Key should focus on the differential effects shown in or inferred from the data. Distractors may include explanations of impacts that are not related to the macro vs. micro scale difference or not related to the factor.
9	TEI	Using the data, match explanations about population size to relevant factors. [Match each of the factors affecting the coral reef to the correct explanation of that factor's effect on the reef food web.]	Match interaction. Interaction direction text should specify whether all choices will be matched. Correct responses show all correct associations between the factors and the explanations. Partial credit would be awarded for a subset of correct responses.
10	TEI	Determine whether population size/carrying capacity explanations are supported or unsupported by the data for a population trend shown in the graph. [Select all the explanations about population size effects that are supported by the data in the graph.]	Interaction type may be drag-drop (sorting which explanations are supported) or drop-down (menus for evaluating each explanation). Explanations to evaluate may include statements that do not adequately explain the trend, statements that explain trends not shown, or statements that explain effects not observed. Correct response shows the multiple explanations that are supported by the data. Partial credit would be awarded for a subset of correct responses.

Student Misconceptions:

*Response options can make use of Student Misconceptions (examples of scientifically incorrect assumptions) related to this performance expectation; references to misconceptions are listed below:

- Organisms higher in a food web eat everything that is lower in the food web.
- Populations exist in states of either constant growth or decline.
- Competition between organisms always involves direct, aggressive interaction (i.e., physical encounters for resources).
- Organisms of the same species do not compete with each other for resources.
- Different kinds of organisms (species) do not compete for resources.
- Plants do not compete for resources, space or light; animals do not compete for resources, shelter, or water.

Students may also believe the following:

- All populations exist in an unchanging steady state unless disturbed.
- Organisms can have only one role in an ecosystem.

Ecosystems: Interactions, Energy, and Dynamics: B.LS2.2

back to “Item Specifications by Performance Expectation”

B.LS2.2. Use mathematical representations to support and revise explanations based on evidence about factors affecting biodiversity and populations in ecosystems of different scales.

OAS-S Clarification Statement:

Examples of mathematical representations include finding the average, determining trends, and using graphical comparisons of multiple sets of data.

OAS-S Assessment Boundary:

Assessment is limited to the provided data.

Science & Engineering Practice:

Using Mathematics and Computational Thinking

- Use mathematical representation to describe and/or support scientific conclusions.

Disciplinary Core Idea:

Interdependent Relationships in Ecosystems

- Ecosystems have carrying capacities, which are limits to the numbers of organisms and populations they can support. These limits result from such factors as the availability of living and nonliving resources and from such challenges such as predation, competition, and disease.
- Organisms would have the capacity to produce populations of great size were it not for the fact that environments and resources are finite. This fundamental tension affects the abundance (number of individuals) of species in any given ecosystem.

Ecosystem Dynamics, Functioning, and Resilience

- A complex set of interactions within an ecosystem can keep its number and types of organisms relatively constant over long periods of time under stable conditions.
- If a modest biological or physical disturbance to an ecosystem occurs, it may return to its more or less original status (i.e., the ecosystem is resilient) as opposed to becoming a very different ecosystem.
- Extreme fluctuations in conditions or the size of any populations, however, can challenge the functions of ecosystems in terms of resources and habitat availability.

Crosscutting Concept:

Scale, Proportion, and Quantity

- Algebraic thinking is used to examine scientific data and predict the effect of a change in one variable on another (e.g., linear growth vs. exponential growth).

Ecosystems: Interactions, Energy, and Dynamics: B.LS2.2

In Lay Terms:

Students should be able to use numerical data and graphic information to draw conclusions about how various living and non-living factors (resource availability, predators, disease, etc.) affect the numbers and types of organisms in ecosystems over time. The numbers and types of organisms may remain fairly constant when resources and conditions follow normal patterns, but they may change when the normal patterns are disturbed. Students should be able to compare ecosystems of different scales as well as interactions within one ecosystem.

Cluster Clarifications:

- Graphical comparisons may include diagrams with numerical values or classic energy/food/biomass models conveying accurate scale and proportion. Graphs can show linear vs. exponential growth.
- A cluster can include interactions within one ecosystem or interactions between ecosystems of different scales, but not both in the same cluster.

Cluster Stimulus Attributes:

Typical stimulus elements:

- graphs, charts, tables
- diagrams (energy/food/biomass models providing scale/proportion)
- other mathematical representations of population data per unit of area in an ecosystem
- text information about conditions/factors for which data have been provided

Possible contexts:

- research studies with mathematical representations showing trends, averages, and data about one or more factors affecting an ecosystem (e.g., average Arctic seal pup survival compared to average air temperatures)
- numerical population relationship data that indicate changes in the numbers and types of organisms over time and at different scales (e.g., North American bison population estimates from 1800 to present)
- research explanations based on mathematical models/analyses addressing the response of ecosystems to both small-scale and large-scale changes (e.g., a summary of scientific studies concerning the response of short-grass prairie habitats to farming and ranching practices)
- mathematical representations demonstrating varying scales of ecosystems in the same geographic region (e.g., distribution of oak-hickory forest in central Oklahoma)
- mathematical representations illustrating interactions between ecosystems at different scales (e.g., how competition affects pond versus large lake reproductive rate of two freshwater snail species)
- mathematical representations of how changes at one scale level can effect multiple other scale levels (e.g., effects of large-scale intensive cattle grazing on the abundance of a rare stream fish species inhabiting only streams of a certain size and temperature)
- scientific/student claims of what limits population size based on mathematical representations or their derivatives (e.g., claims made based on a model simulating the effects of changes in two limiting factors of a bird species population)
- mathematical representations of both modest and extreme environmental changes and their effect on existing populations (e.g., effects of different patterns of periodic fire on the distribution of two woody plant species)

Content and evidence to be included: numerical data and graphs as evidence to support explanations about the relationship between environmental factors and biodiversity and stability of ecosystems

Types of student responses that need to be supported: describing, inferring, and making conclusions in regards to what the mathematical data show about how various factors influence biodiversity and stability of an ecosystem; revising explanations using data

Allowable Item Types:

- MC
- TEI

Model Item Descriptions for B.LS2.2:

#	Item Type	Model Stem (Items ask students to...)	Response Characteristics*
1	MC	Determine which explanation for how variation of a limiting factor can adversely affect or benefit an existing or introduced population (biodiversity) is supported by the mathematical data.	Key should focus on the adverse or beneficial aspect of the factor shown in the data. Distractors may include explanations unsupported by the data or explanations that do not relate limiting factors in an appropriate way to the population response.
2	MC	Identify appropriate revision of an explanation supported by averages of population growth and/or trends in growth. [Which revised explanation would best account for the most recent population census of alligators in the park?]	Key may focus on a revision that adds detail, clarity, or additional data support to the explanation. Distractors may include explanations that detract from or reduce the value of the given explanation or explanations that add information but do not logically account for all of the referred-to data.
3	MC	Revise an explanation based on new/additional data for a causative relationship between a factor (predation, competition, disease, drought, flood, climatic shift, etc.) and the diversity or stability of an ecosystem. [Based on the second study's data, which revised explanation for the effect of decreased farming on the distribution of antelope is better supported?]	Distractors may include explanations of relationships irrelevant to the causative factor(s).
4	MC	Select applicable age structure diagrams, population size graphs, extrapolations of future growth, etc. that display the numerical data. [Which graph best represents how the three species of sunfish respond to muddy water?]	Key may focus on direct or inferred relationships extending from the numerical evidence. Distractors may include diagrams or displays with inaccurate or unsupported characteristics (including common misconceptions).
5	MC	Identify the data/evidence from the mathematical representation that supports an explanation for the impact of various conditions or factors (e.g., weather, disaster, competition, disease) on the number/variety of species in an ecosystem. [Which evidence supports the scientists' conclusion about the effect of chronic wasting disease on mule deer populations in the Rocky Mountains?]	Key may focus on data that support a direct or inferred relationship between the relevant factor and ecosystem diversity. Distractors may include unsupported or incomplete explanations, explanations related to other factors, or explanations that impact ecosystem characteristics other than diversity of species.
6	MC	Determine <i>how/why</i> the data in the mathematical representation support/do not support a given explanation for biodiversity or ecosystem change. [Which statement best describes how the data for moth and tree populations in the Ouachita Mountains relate to the students' explanation of how species diversity has changed in this ecosystem?]	Key should provide reasoning for how the data connects to the explanation. Key may focus on numerical evidence for the explanation. Distractors may include represented elements that do not support the explanation, invalid reasoning, or factors not included in the representation.

#	Item Type	Model Stem (Items ask students to...)	Response Characteristics*
7	MC	<p>Identify the explanation for the impact of various conditions or factors (e.g., weather, disaster, competition, disease) on ecosystem stability that is supported by the mathematical data.</p> <p>[Which conclusion about the condition of the pond ecosystem before and after introduction of grass carp is supported by the data?]</p>	<p>Distractors may include explanations focused on data elements that do not support the premise/conclusion, explanations related to factors that are constant or unmeasured, or factors that affect ecosystem characteristics unrelated to stability.</p>
8	MC	<p>Compare how two or more local populations at different scales are differentially affected by a factor in the ecosystem.</p> <p>[Which statement about how predation affects the tomato horn worms in individual gardens versus wild prairie habitats is supported by the population data?]</p>	<p>Key may focus on trends or significant differences in populations at distinctly different ecosystem scales.</p> <p>Distractors may include invalid statements related to the population or general statements derived from misconceptions.</p>
9	MC	<p>Use the data to explain how the same causative factor (drought, fire, invasive predation/vegetation, disease, etc.) differentially impacts ecosystem stability in two different ecosystems.</p> <p>[Which explanation for the way drought impacts forest versus prairie ecosystems is supported by the population data?]</p>	<p>Key may focus on clear differences between the two ecosystems in populations, available resources, or distribution of species due to the causative factor.</p> <p>Distractors may include explanations involving ecosystem differences unrelated to the causative factor or explanations involving unmeasured/unrelated factors.</p>
10	MC	<p>State conclusions from the graph/data that reflect the relationship between variables related to biodiversity or stability.</p>	<p>Key may focus on direct or inferred relationships.</p> <p>Distractors may include misconceptions or misinterpretation of the data.</p>
11	MC	<p>Recognize or describe the mathematical pattern in the data that indicates what relationship exists or what change is taking place in the ecosystem.</p> <p>[Based on the data, what is the relationship between the dependent and independent variables studied in this ecosystem?]</p> <p>[How does the graph show the way in which the fish populations are related?]</p> <p>[What pattern in the graphs demonstrates the different effect of herbicides on the species in the pond versus in the river drainage?]</p>	<p>Distractors may include expressions of a numeric or quantitative scale that do not correspond with the relevant ecosystem change.</p>
12	MC	<p>Make or justify predictions about the changes in organism numbers or the relative size/degree of ecosystem change expected using the math representation.</p> <p>[Which data support the students' prediction about the river ecosystem's stability after 1990?]</p>	<p>Predictions may be plausible outcome statements regarding general ecosystem diversity/stability or inferred responses of the dependent variable.</p> <p>Distractors may include cause-and-effect statements relating irrelevant variables or predicted results that are not supported by the data.</p>

#	Item Type	Model Stem (Items ask students to...)	Response Characteristics*
13	TEI	Select appropriate explanations of impact points on population graphs to indicate the relationships between causative factors and ecosystem stability. [Select the explanation that best fits each indicated point on the population graphs.]	Interaction type may be drop-down or hot-spot depending on selection requirements. May give cause and effect options. Relationships are inferred from food web and species distribution data in the stimulus. Correct responses show/select all correct explanations as required. Partial credit would be awarded for a subset of correct responses.

Student Misconceptions:

*Response options can make use of Student Misconceptions (examples of scientifically incorrect assumptions) related to this performance expectation; references to misconceptions are listed below:

- Populations exist in states of either constant growth or decline.
- Competition between organisms always involves direct, aggressive interaction. Exploitative competition (e.g., getting to the resource before other organisms) is not competition.
- Organisms of the same species do not compete for resources.
- Different kinds of organisms (species) do not compete for resources.
- Plants do not compete for resources, space or light; animals do not compete for resources, shelter, or water.
- Plants and animals do not compete (with each other) for space or water.
- If a population in a food web is disturbed, there will be little or no effect on populations that are not within the linear sequence in the food web (e.g., no effect on populations below it in the food web, such as if a predator is removed, there will be no effect on prey).
- Organisms higher in a food web eat everything that is lower in the food web.
- If the size of one population in a food web is altered, all other populations in the web will be altered in the same way.
- A change in the size of a prey population has no effect on its predator population.
- Changes in a population in a food web do not affect the populations of any other organism in the food web.
- The top predator in a food web will never be significantly affected by changes in the populations of organisms below it in the food web.
- Varying the population size of species will only affect the others that are directly connected through a food chain.

Students may also believe the following:

- Organisms can have only one role in an ecosystem.
- Populations exist in constant states that neither grow nor decline.
- Diversity is the variation of traits in a population.
- Variation is the number and distribution of species in a community.

Ecosystems: Interactions, Energy, and Dynamics: B.LS2.3

back to “Item Specifications by Performance Expectation”

B.LS2.3. Construct and revise an explanation based on evidence for the cycling of matter and the flow of energy in aerobic and anaerobic conditions.

OAS-S Clarification Statement:

Emphasis is on describing the role of aerobic and anaerobic respiration in the conservation of matter and flow of energy into, out of, and within various ecosystems (e.g., chemosynthetic bacteria near deep ocean vents, yeast in various environments, muscle cells during exertion, water-logged plants).

OAS-S Assessment Boundary:

Assessment focuses on the conceptual understanding and does not include the specific chemical processes of either aerobic or anaerobic respiration.

Science & Engineering Practice:

Constructing Explanations

- Construct and revise an explanation based on valid and reliable evidence obtained from a variety of sources (including students’ own investigations, models, theories, simulations, peer review) and the assumption that theories and laws that describe the natural world operate today as they did in the past and will continue to do so in the future.

Disciplinary Core Idea:

Cycles of Matter and Energy Transfer in Ecosystems

- Photosynthesis and cellular respiration (including anaerobic processes) provide most of the energy for life processes.

Crosscutting Concept:

Energy and Matter

- Energy drives the cycling of matter within and between systems.

In Lay Terms:

Students should be able to use evidence to explain how cellular respiration (both aerobic and anaerobic) provides most of the energy for life processes. This energy drives the transportation of matter within and between biological systems.

Cluster Clarifications: (none)

Cluster Stimulus Attributes:

Typical stimulus elements:

- models of relationships between cellular respiration, available energy, and/or cycling of matter
- investigation results related to cellular respiration and matter/energy flow

Possible contexts:

- student-generated or referenced models that demonstrate how cycling of matter and/or flow of energy and the drivers of these processes
- research evidence that demonstrates examples of differential energy production in various conditions (aerobic and anaerobic)
- investigations that include manipulation of variables in aerobic or anaerobic conditions to measure energy and matter inputs/outputs

Content and evidence to be included: models, diagram, and/or experimental data that can be used as evidence for how energy flows and matter cycles in various conditions

Types of student responses that need to be supported: constructing explanations of matter cycling and energy flow using data and models, as well as describing evidence and reasoning to support or evaluate explanations

Allowable Item Types:

- MC
- TEI

Model Item Descriptions for B.LS2.3:

#	Item Type	Model Stem (Items ask students to...)	Response Characteristics*
1	MC	Determine which explanation for how cellular respiration impacts the flow of energy in organisms or ecosystems is supported/not supported by the data. [Based on the experimental data, which is the best explanation of the energy produced during cellular respiration?]	Key may focus on conversion of chemical energy in glucose into forms used for life functions as shown by the data. Distractors may include explanations of energy flow unrelated to respiration, descriptions of chemical/physical changes rather than energy flow, or respiration effects in other organisms or ecosystems.
2	MC	Determine which explanation for how cellular respiration impacts the cycling of matter in organisms or ecosystems is supported/not supported by the data. [Which statement best explains the connection between carbon flow in the prairie ecosystem and the process of cellular respiration?]	Key may focus on C-H-O reactions (without being too specific, per assessment boundary) and molecular exchanges. Distractors may include inaccurate or unrelated explanations of matter transformations or explanations of matter involved in other functions of organisms or ecosystems.
3	MC	Revise an explanation based on contrasting energy-availability data for aerobic versus anaerobic conditions. [Which new explanation is best supported by the additional data for aerobic respiration in muscles cells?]	Distractors may include explanations that do not adequately describe or do not address the contrasting data.
4	MC	Identify the data that support an explanation of energy related to respiration. [Which data support the explanation about energy consumption in the cells?]	Key may focus on data that show a relationship between aerobic or anaerobic respiration and a corresponding high or low level of energy consumption. Distractors may include identification of extraneous data or data that do not adequately support the explanation.
5	MC	Identify appropriate explanations of cause-effect relationships in the respiration process indicated by the data. [Which statement explains the relationship between oxygen availability and carbon dioxide production in yeast cells?]	Key should focus on relationships critical to the transfer of energy or matter via either aerobic or anaerobic respiration. Distractors may include statements that do not sufficiently explain, statements that explain alternate phenomena, or statements lacking critical conceptual connections.
6	MC	Develop an explanation for differences in data (different respiration outputs—energy or matter) due to aerobic versus anaerobic conditions. [Which statement best explains why bacterial cells in the closed dish consumed less glucose than the bacteria in the open dish?]	Key should focus on/include reasoning for the contrast in outputs based on the data. Distractors may include statements explaining reasoning for other outcomes of protein synthesis or functions of DNA or erroneous explanations for specialization.

#	Item Type	Model Stem (Items ask students to...)	Response Characteristics*
7	MC	Reason from the evidence to identify an explanation for which respiration mechanism (aerobic or anaerobic) applies to a particular phenomenon or example. [Which explanation for the mechanism of energy production applies to the making of yogurt?]	Key may focus on conditions in combination with the data evidence for the mechanism. Distractors may include statements applying to the alternate mechanism (aerobic/anaerobic as appropriate) or statements about energy unrelated to the respiration mechanism.
8	MC	Identify evidence that supports a student explanation for the transformation of organic molecules to produce energy during cellular respiration. [What evidence supports the students' explanation for how liver cells obtain the energy for active transport of waste into the urinary tract?]	Key should focus on data evidence of processes requiring energy or decomposing organic molecules. Distractors may include data that do not provide sufficient/valid evidence or data related to other cellular/genetic processes.
9	MC	Provide additional clarification to improve an explanation for cellular respiration based on conditional limits or resources. [Which additional statement/clarification will best improve the explanation for the cellular process that caused cells in an aerobic condition to require oxygen?]	Key may focus on statements linking the limits or resources of the condition to the respiration process. Distractors may include information/data/trivial statements that do not provide an improved explanation.
10	MC	Explain the data support for how the different respiration processes provide energy advantages or disadvantages to organisms. [Which statement best explains what the data illustrate about both aerobic and anaerobic respiration and the energy needs of complex organisms?]	Key may focus on advantages or disadvantages to organisms from using either or both (aerobic, anaerobic) respiration processes. Distractors may include data characteristics that do not connect the types of respiration to organism survival.
11	TEI	Explain the process of respiration by constructing a model of what is accomplished throughout the process (arranging explanations in sequential order). [Explain how cells obtain energy from food molecules (by dragging statements to each label box).]	Drag-drop interaction. Item may have more draggable options/choices than are needed to construct the model explanation. Correct responses show the correct sequence/model explanation with all necessary labels/selected text. Partial credit would be awarded for a subset of correct responses.

#	Item Type	Model Stem (Items ask students to...)	Response Characteristics*
12	TEI	<p>Construct an explanation for how energy is transformed during aerobic or anaerobic respiration by providing an explanation statement, evidence, and reasoning based on experimental data.</p> <p>[Identify an explanation, evidence, and reasoning for the process by which yeast cells produce carbon dioxide.]</p>	<p>Drag-drop interaction.</p> <p>Could also be completed with match or drop-down interaction in some cases.</p> <p>Item provides table/columns for placing and connecting explanation, evidence, and reasoning.</p> <p>Multiple pieces of evidence/reasoning could be required.</p> <p>Correct responses show accurate identification and association of explanation, evidence, and reasoning.</p> <p>Partial credit would be awarded for a subset of correct responses.</p>

Student Misconceptions:

*Response options can make use of Student Misconceptions (examples of scientifically incorrect assumptions) related to this performance expectation; references to misconceptions are listed below:

From digitalcommons.library.umaine.edu/etd/1607/

- Carbon atoms (or carbon dioxide molecules) are an energy source for plants.
- Sugar (glucose) provides energy directly for cell functions (no ATP is necessary).
- Cells never require oxygen to undergo respiration.
- Plants and animals use gases to produce energy, not carbohydrate molecules (glucose).
- Respiration is necessary to eliminate carbon dioxide, not to produce energy.
- Respiration occurs in organs and tissues, not in cells.
- Respiration cannot occur without oxygen (or carbon dioxide) present.

Ecosystems: Interactions, Energy, and Dynamics: B.LS2.4*

back to “Item Specifications by Performance Expectation”

B.LS2.4. Use a mathematical representation to support claims for the cycling of matter and flow of energy among organisms in an ecosystem.

OAS-S Clarification Statement:

Emphasis is on using a mathematical model of stored energy in biomass to describe the transfer of energy from one trophic level to another and that matter and energy are conserved as matter cycles and energy flows through ecosystems. Emphasis is on atoms and molecules such as carbon, oxygen, hydrogen and nitrogen being conserved as they move through an ecosystem.

OAS-S Assessment Boundary:

The assessment should provide evidence of students’ abilities to develop and use energy pyramids, food chains, food webs, and other models from data sets.

Science & Engineering Practice:	Disciplinary Core Idea:	Crosscutting Concept:
<p>Using Mathematics and Computational Thinking</p> <ul style="list-style-type: none">• Use mathematical representations to describe and/or support scientific conclusions.	<p>Cycles of Matter and Energy Transfer in Ecosystems</p> <ul style="list-style-type: none">• Plants or algae form the lowest level of the food web.• At each link upward in a food web, only a small fraction of the matter consumed at the lower level is transferred upward, to produce growth and release energy in cellular respiration at the higher level.• Given this inefficiency, there are generally fewer organisms at higher levels of a food web.• Some matter reacts to release energy for life functions, some matter is stored in newly made structures, and much is discarded.• The chemical elements that make up the molecules of organisms pass through food webs and into and out of the atmosphere and soil, and they are combined and recombined in different ways.• At each link in an ecosystem, matter and energy are conserved.	<p>Energy and Matter</p> <ul style="list-style-type: none">• Energy cannot be created or destroyed—it only moves between one place and another place, between objects and/or fields, or between systems.

In Lay Terms:

Students should be able to use mathematical models (ecological pyramids illustrating proportional/numerical quantities of energy and mass, and food web diagrams highlighting the flow of matter or energy) as evidence to make or support claims about the movement of matter and/or energy through an ecosystem. Emphasis is on the relative amounts of matter or energy being transferred and hence the degree of efficiency/inefficiency in the system.

**associated sample cluster included*

Ecosystems: Interactions, Energy, and Dynamics: B.LS2.4*

Cluster Clarifications:

- Avoid misleading portrayal of species with multiple roles in ecosystems/food webs/food chains (e.g., a human portrayed only as an herbivore, an omnivorous raccoon portrayed only as a carnivore); avoid ambiguous or overly complex role combinations. Roles must be well documented with source material.
- The terms primary, secondary, and tertiary consumers may be used as labels, but if not defined or used as labels, the terms should not be used in the stimulus and items. Preference is for referring to first level, second level, third level consumers, etc.
- Mathematic representations should be conceptual, not algebraic expressions (e.g., $10y = x$).
- Students should not be expected to balance chemical equations or perform stoichiometry.

Cluster Stimulus Attributes:

Typical stimulus elements:

- text descriptions of ecosystems
- diagrams of food webs and ecological pyramids
- data tables and graphs of biomass or net productivity
- diagrams of biogeochemical cycles with data

Possible contexts:

- ecosystems familiar to Oklahoma students through existence in the state or common coverage in curriculum
- scientists' application of computer models/simulations describing relationships within ecosystems
- predator-prey relationships that affect biomass over time
- ecological investigations and resulting data about trophic levels, energy sources, and/or biomass for organisms found in an ecosystem
- natural or human disturbances that affect matter and energy flow in an ecosystem
- rates or amounts of nutrients in biogeochemical cycles, with emphasis on biotic portions of the cycle

Content and evidence to be included: data regarding cycling of matter (may include roles of central molecules/elements) and/or flow of energy within an ecosystem

Types of student responses that need to be supported: describing and analyzing mathematical relationships in provided data/representations to make, analyze, justify, or reject claims about matter and energy flow

Allowable Item Types:

- MC
- TEI

Model Item Descriptions for B.LS2.4:

#	Item Type	Model Stem (Items ask students to...)	Response Characteristics*
1	MC	Choose the most appropriate mathematical representation for parts or relationships in the system. [Which mathematical (algebraic) expression best represents the parts and/or relationships shown within the food web?]	Key may focus on the mathematical representation that best illustrates the specified parts or relationships. Distractors may include expressions that contain a subset of the factors seen in the correct expression or that contain similar but not identical factors.
2	MC	Make a conclusion or claim describing what the mathematical representation shows about matter or energy distribution. [Which statement best describes what the food pyramid shows about the amount of matter at different levels in the ecosystem?]	Key may focus on describing what the representation illustrates overall about matter or energy proportions. Distractors may include unsupported claims or claims unrelated to energy flow.
3	MC	Relate the mathematical representation to the claim/describe how the mathematical representation links to the concept (in the claim). [How do the biomass relationships shown in the pyramid relate to the student's claim about matter or energy flow?]	Key may focus on how the mathematical representation provides support for the concept presented in the claim (reasoning with content). Distractors may include explanations that misinterpret the relationship described in the expression or representation.
4	MC	Identify which claim for movement of matter, energy flow, or efficiency is supported based on the mathematical representation. [Which claim about the percentage of energy stored at a given trophic level is supported (given an ecological pyramid or a data table showing energy stored at each level)?] [Which claim about nitrogen's role in the grassland ecosystem is supported by the data (role of elements)?]	Key may focus on a claim explaining reasoning for movement of matter, energy flow, or efficiency based on variable relationships shown in the data (typically with more inference than model stem #2). Distractors may include claims unsupported by the data or irrelevant to the matter or energy concept.
5	MC	Identify which evidence from the mathematical representation best supports the claim for movement of matter or energy flow.	Key may focus on data directly supporting the claim. Distractors may include claims describing levels of energy transfer varying from those indicated in the ecological pyramid or the data table.
6	MC	Determine which claim about the conservation of matter or energy within the biological system is supported by the data. [Which claim about the exchange of matter between trophic levels is supported by the data?]	Key may focus on gradual reduction in available energy and food at each level due to energy and matter being converted into other forms. Distractors may include claims describing loss or gain of matter between trophic levels or other claims based on misconceptions and not supported by the data.

#	Item Type	Model Stem (Items ask students to...)	Response Characteristics*
7	MC	Use mathematical data to select/support a claim for how energy/matter transport in the biological system results in inefficiency. [Based on the biomass pyramid data, which claim about how energy/matter moves through the ecosystem is supported?]	Key may focus on only the food portion of biomass providing energy to the next trophic level; various other processes (heat loss, movement, reproduction, digestion, growth and development, etc.) result in inefficiency in both energy and matter transformations at each level. Distractors may include statements describing inverse/tangential/irrelevant relationships to those seen in the data (per common misconceptions) or comparisons of uncorrelated data.
8	MC	Determine which claim about the relationship between numbers of organisms (trophic level populations) and total biomass is supported by the data. [Which claim about the relationship between the number of organisms at each trophic level and the biomass stored at each level is supported by the population data and the biomass pyramid?]	Key may focus on correlations between numbers of organisms and biomass or reasons for seemingly disproportionate biomass due to accumulations/depletions (e.g., large ocean predator biomass exceeding producer populations at a particular time, great amounts of biomass stored cumulatively over time in tree wood, etc.). Distractors may include claims describing inverse relationships to those seen in the data or comparisons of uncorrelated data.
9	MC	Predict how and why a mathematical representation would change due to an environmental shift or disturbance. [Which pyramid shows how the grassland ecosystem might respond for a short time following a prairie fire?]	Key should focus on how the shift or disturbance would affect the direction or extent of energy or matter flow, biomass accumulation at different trophic levels, or the efficiency of energy and matter transformations at different trophic levels (mathematical representation). Distractors may include incorrect predictions or be based on misconceptions or misinterpretations of the data.
10	MC	Compare and justify which of two or more alternate claims is best supported based on the mathematical representation/data. [Which claim is the most consistent with the way energy is distributed in the food web and why?]	Key may focus on the validity of one claim over another in terms of the pattern of energy or matter flow/distribution shown in the data. Distractors may include claims/justifications that are inconsistent with the data presented or are incorrect interpretations of the various claims based on misconceptions.
11	TEI	Associate claims about organisms and available energy with their appropriate positions on a biomass pyramid. [Indicate the available energy for various organisms by showing the organisms' positions on the biomass pyramid.]	Drag-drop interaction. Correct responses show all organisms on the pyramid in their correct places. Partial credit would be awarded for a subset of correct responses.

#	Item Type	Model Stem (Items ask students to...)	Response Characteristics*
12	TEI	<p>Given a list of energy/matter claims in a hierarchy of complexity and detail, distinguish those that are supported from those that are unsupported by the given food web/pyramid data.</p> <p>[Select <u>all</u> of the claims about energy in the food web that are supported by the research data.]</p>	<p>Interaction type may be drag-drop (sorting which claims are supported) or drop-down (menus for evaluating each claim).</p> <p>Claims to evaluate may include those that represent misconceptions or invalid interpretations of the data.</p> <p>Correct responses show the multiple claims that are supported by the data.</p> <p>Partial credit would be awarded for a subset of correct responses.</p>

Student Misconceptions:

*Response options can make use of Student Misconceptions (examples of scientifically incorrect assumptions) related to this performance expectation; references to misconceptions are listed below:

- Organisms and other things can “use up” energy.
- Plants take in food from the outside environment, and/or plants get their food from the soil via roots.
- Organisms higher in a food web eat everything that is lower in the food web.
- The top of the food chain has the most energy because it accumulates up the food chain.
- Populations higher on a food web increase in number because they deplete those lower in the food web.
- There are more herbivores because people keep and breed them. Decomposers release some energy that is cycled back to plants.
- The number of producers is high to satisfy consumers.
- Varying the population size of species will only affect the others that are directly connected through a food chain.
- A model is always a three-dimensional object. Therefore, pictures, diagrams, graphs, written descriptions, and abstract mathematical or conceptual models are not models.

Sample Cluster for B.LS2.4:

Use the information to answer the following questions.

A group of students studied a grassland ecosystem. The students learned that biomass is a measure of the amount of matter in an ecosystem. They also learned that energy is primarily transferred through an ecosystem in the form of food. The students created a diagram to show what they learned.

Matter and Energy Flow in a Grassland Ecosystem

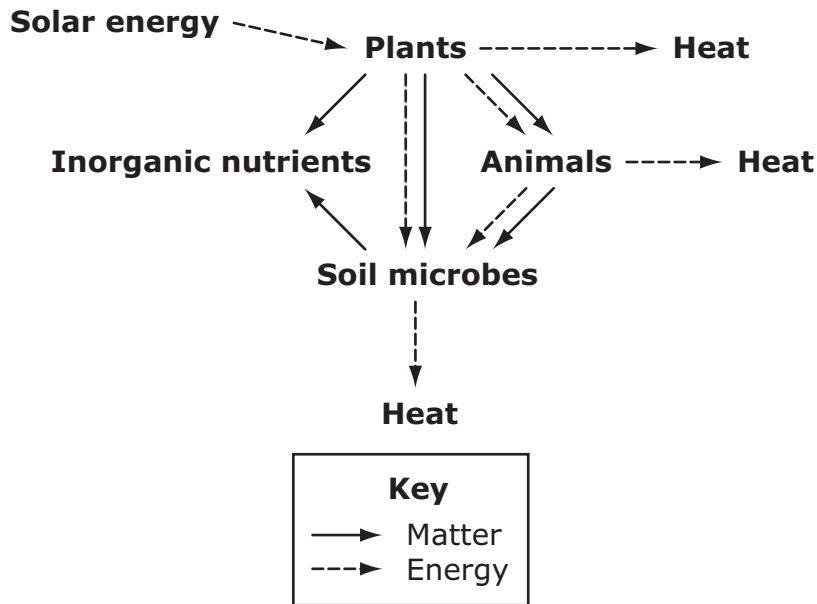

After the students created the diagram, their teacher asked them to answer this question: *How is biomass related to energy flow in the grassland ecosystem?*

To help them answer the question, the students found biomass data. They created this second diagram to illustrate the data.

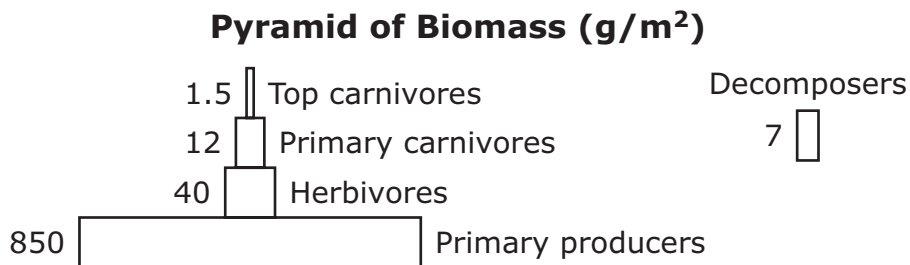

(Items on the following pages)

- 1** A student makes a claim about how the heat energy shown in the diagram “Matter and Energy Flow in a Grassland Ecosystem” helps explain the amounts of biomass shown in the diagram “Pyramid of Biomass.”

Claim: As heat energy is released by consumers, less heat is available to organisms at the next level. Therefore the higher pyramid levels contain less biomass.

Which statement best analyzes the student’s claim?

- A** The claim is supported; organisms store heat energy in food to produce biomass, and the available heat energy decreases at the higher levels.
- B** The claim is supported; the amount of biomass stored at higher levels is very small, and small amounts of biomass show that energy and matter are lost from a system.
- C** The claim is rejected; heat energy flows in all directions among the levels, and this allows food energy to be stored within biomass at all levels.
- D** The claim is rejected; energy from food is used to produce biomass, and the conversion of some of this energy to heat in each level reduces energy to be stored in biomass.

Standard: Use a mathematical representation to support claims for the cycling of matter and flow of energy among organisms in an ecosystem.

Cognitive Complexity:

SEP: N/A

DCI: Med

CCC: Med

Overall Cognitive Complexity: Moderate Support

Distractor Rationale:

- A. The student may think energy is stored as heat energy in food.
- B. The student may think that energy and matter within a system can be lost from a system instead of being transformed to different forms or transferred to different organisms within the system.
- C. The student may think heat flows in all directions, and food energy is stored as biomass.
- D. Correct. Food is used to produce biomass, and this conversion leads to a loss of heat energy from one trophic level to the next higher trophic level, reducing the energy stored as biomass.**

Study the information. Then answer the following three questions.

A group of students studied a grassland ecosystem. The students learned that biomass is a measure of the amount of matter in an ecosystem. They also learned that energy is primarily transferred through an ecosystem in the form of food. The students created a diagram to show what they learned.

Matter and Energy Flow in a Grassland Ecosystem

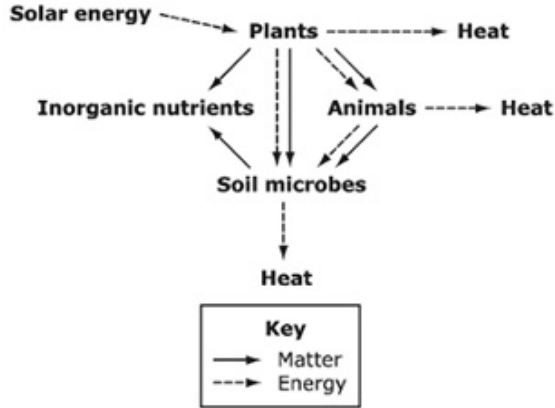

After the students created the diagram, their teacher asked them to answer this question: *How is biomass related to energy flow in the grassland ecosystem?*

To help them answer the question, the students found biomass data. They created this second diagram to illustrate the data.

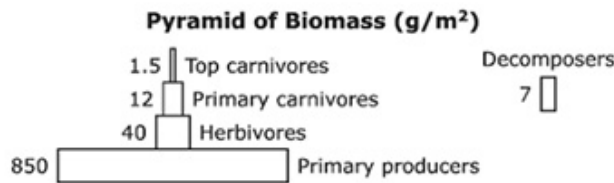

Three claims about energy flow in the ecosystem are listed. Some of the claims are supported by the information in the diagrams, while other claims are not supported. **Identify whether each claim is “supported” or “not supported” based on the reasoning provided.** Use the drop-down menu next to each claim to select your responses. To select an answer click the menu and then click the desired answer.

Claim	Supported or Not Supported?
The plants receive food energy from other organisms and from sunlight.	-Select an Answer-
The amount of stored energy changes as it flows between different trophic levels.	-Select an Answer-
The energy available to animals and microbes is limited by photosynthesis in plants.	-Select an Answer-

Standard: Use a mathematical representation to support claims for the cycling of matter and flow of energy among organisms in an ecosystem.

Cognitive Complexity:

SEP: N/A

DCI: Med

CCC: High

Overall Cognitive Complexity: Moderate Support

Distractor Rationale:

Correct. Plants receive energy for food only from the Sun. As shown by the loss of heat, the total amount of energy at each trophic level changes. The plants are the only producers shown in the diagram and therefore are the only source of food energy within the system for consumers and decomposers.

The student may think that the arrows point to what is being consumed, rather than the consumers in the diagram. The student may think that heat is not a form of energy. The student may not understand that the amount of energy in the system is constrained.

Scoring Rubric:

Score	Description
2	2 points for 3 correct options selected
1	1 point for 2 correct options selected
0	
Blank	

Sample Response

Statement	Supported or Not Supported?
The plants receive food energy from other organisms and from sunlight.	Not Supported: the food web shows a single dashed arrow from the sun to the plants
The amount of stored energy changes as it flows between different trophic levels.	Supported: the food web shows arrows between the organisms and heat
The energy available to animals and microbes is limited by photosynthesis in plants.	Supported: the arrows trace all energy back to the use of sunlight by plants.

3 Based on the diagrams, which mathematical expression correctly compares the amounts of energy in different parts of the ecosystem?

- A** producer energy $>$ herbivore energy
- B** carnivore energy $>$ herbivore energy
- C** carnivore energy $=$ herbivore energy
- D** producer energy $=$ herbivore energy

Standard: Use a mathematical representation to support claims for the cycling of matter and flow of energy among organisms in an ecosystem.

Cognitive Complexity:

SEP: Low

DCI: Low

CCC: Low

Overall Cognitive Complexity: Moderate Support

Distractor Rationale:

- A. Correct. There is more stored producer energy than stored herbivore energy.**
- B. The student may think that carnivores have more energy based on their trophic level.
- C. The student may not understand that heat is lost between the trophic levels of herbivores and carnivores.
- D. The student may not understand that heat is lost between the trophic levels of herbivores and producers.

Ecosystems: Interactions, Energy, and Dynamics: B.LS2.5

back to “Item Specifications by Performance Expectation”

B.LS2.5. Develop a model to illustrate the role of photosynthesis and cellular respiration in the cycling of carbon among the biosphere, atmosphere, hydrosphere, and geosphere.

OAS-S Clarification Statement:

Examples of models could include simulations and mathematical models. The emphasis is on the movement of carbon.

OAS-S Assessment Boundary:

Assessment does not include the specific chemical steps of photosynthesis and respiration.

Science & Engineering Practice:	Disciplinary Core Idea:	Crosscutting Concept:
<p>Developing and Using Models</p> <ul style="list-style-type: none"> Develop a model based on evidence to illustrate the relationships between systems or components of a system. 	<p>Cycles of Matter and Energy Transfer in Ecosystems</p> <ul style="list-style-type: none"> Photosynthesis and cellular respiration are important components of the carbon cycle, in which carbon is exchanged among the biosphere, atmosphere, oceans, and geosphere through chemical, physical, geological, and biological processes. <p>Energy in Chemical Processes and Everyday Life</p> <ul style="list-style-type: none"> The main way that solar energy is captured and stored on Earth is through the complex chemical process known as photosynthesis. 	<p>Systems and System Models</p> <ul style="list-style-type: none"> Models (e.g., physical, mathematical, computer models) can be used to simulate systems and interactions—including energy, matter, and information flows—within and between systems at different scales.

In Lay Terms:

Students should be able to construct models to show the movement of carbon through biological systems and between organisms and the environment. Models should illustrate that the processes of photosynthesis (primarily in plants) and cellular respiration in all organisms utilize carbon compounds to provide energy for life on Earth. Models should also demonstrate that carbon undergoes a continuous process of cycling as various compounds in the geosphere, biosphere, hydrosphere, and atmosphere of Earth.

Cluster Clarifications:

- The cluster stimulus should address 2 or 3 of the Earth systems identified in the performance expectation (i.e., biosphere, atmosphere, hydrosphere, and geosphere).
- Relevant components that students need to include in the model are photosynthesis inputs and outputs, cellular respiration inputs and outputs, and Earth system components (e.g., biosphere, atmosphere, hydrosphere, geosphere).
- Interactions and relationships that students need to represent and describe in the model include (1) exchange of carbon between organisms and the environment (Earth’s systems) via photosynthesis and cellular respiration inputs and outputs, and (2) storage of some carbon in organisms as part of the carbon cycle.
- Students are not expected to calculate quantities of inputs, outputs, products, or reactants.
- In order to address the SEP and CCC, when students develop a model, they are expected to construct a model from evidence/data, complete a model, or choose the best model to illustrate a given phenomenon. A physical demonstration of a phenomenon is not a model as it does not differ from the reality it represents (in materials, scale, etc.).

Ecosystems: Interactions, Energy, and Dynamics: B.LS2.5

Cluster Stimulus Attributes:

Typical stimulus elements:

- graphs, data tables, and textual descriptions of the processes or steps in the carbon cycle, respiration, and/or photosynthesis
- partial diagrams, equations, models, simulations, flow charts of these processes or steps

Possible contexts:

- creating and/or completing diagrams, models, or simulations illustrating the roles and impacts of photosynthesis and/or cellular respiration in the carbon cycle
- creating and/or completing diagrams, models, or simulations illustrating inputs and outputs of photosynthesis and/or cellular respiration
- creating and/or completing diagrams, models, or descriptions illustrating biological mechanisms and processes that move carbon between Earth systems

Content and evidence to be included: data, descriptions, and/or partial models to support model creation/ completion and/or revision

Types of student responses that need to be supported: creating and improving/modifying models, through the use of evidence, in order to describe and analyze the role of photosynthesis and cellular respiration in carbon cycling within and among Earth's system

Allowable Item Types:

- MC
- TEI

Model Item Descriptions for B.LS2.5:

#	Item Type	Model Stem (Items ask students to...)	Response Characteristics*
1	MC	Identify the impacts of photosynthesis/ respiration on the carbon cycle that specific components of the model need to show. [How can the model be developed to show the importance of process X?]	Key may focus on consumption or production of CO ₂ , organic substrates, or inorganic biological byproducts (such as carbonate minerals) in the carbon cycle. Distractors may include descriptions of components of the aerobic respiration process that are not high in importance (per the specific cycle or process).
2	MC	Identify the cycle sequence of a key process associated with the carbon cycle model. [At which position in the model being developed would the description of glucose decomposition belong?]	Key may focus on the description of carbon-based molecule reactions/transitions at the appropriate step in the carbon cycle model (without being too specific, per assessment boundary). Distractors may include processes not related to or dependent upon the step(s) indicated.
3	MC	Describe the purpose/system that needs to be shown by a photosynthesis, respiration, or carbon cycle model being developed. [To represent X, which series of processes need to be shown in the model?]	Key may focus on transfer of carbon between Earth spheres or biological energy storage and transfer. Distractors may include misinterpretations/ misconceptions of the model and/or its components and the associated purposes.
4	MC	Identify relationships between inputs and outputs that should be shown in a carbon cycle, photosynthesis, or respiration model. [Which statement describes how to show the relationship between photosynthesis and carbon dioxide in the model?] [How should the relationship between available sunlight and the amount of glucose produced in the algae be shown in the model?]	Key may focus on links between forms of carbon or the energy processes that drive or are driven by the carbon cycle. Distractors may include statements describing alternate relationships or misconceptions about functions/processes.
5	MC	Describe the representations needed in the model to show interactions among components of the model related to energy transactions. [What is one way the model can be developed to show how carbon is related to energy storage in plants?]	Key may focus on the role of carbon molecules in the capture of sunlight energy by plants, their role in biological energy storage via organic hydrocarbon molecules, and/or its role in the release/use of energy via respiration. Distractors may include descriptions of roles not related to the specified process/function or interactions that occur but are not involved directly in the process.
6	MC	Complete/modify the model to demonstrate the underlying concept. [Which change will allow this model to demonstrate organic carbon cycling to inorganic forms?]	Key may focus on missing components or additional model steps that illustrate a key process or outcome of the cycle. Distractors may include components associated with model components but not involved in the underlying model concept.

#	Item Type	Model Stem (Items ask students to...)	Response Characteristics*
7	MC	Identify the best model to describe a given carbon phenomenon/process/relationship shown in the data. [Which molecular model demonstrates how carbon is cycled from plants to the atmosphere?]	Key may focus on the dependent variable in the data and its corresponding place in the model. Distractors may include models that show additional components or unrelated processes/relationships.
8	MC	Explain how the model being developed can show the underlying concept of carbon exchange between hydrosphere, geosphere, biosphere, and atmosphere. [Which statement explains how the model being developed can demonstrate carbon's importance on Earth?]	Key may focus on the transfer of carbon between the various Earth spheres as a process that impacts the geology, climate, and ecosystems of Earth. Distractors may include statements that discuss carbon but do not define its importance as shown in the model.
9	MC	Explain <i>how</i> collected data/evidence support a given model of carbon cycling (fit of model and data set). [Which statement describes how the data collected in this investigation support the model being developed?]	Key may focus on characteristics of the data set that support the model or its components, using data as evidence plus content reasoning as appropriate. Distractors may include statements related to data that do not support the model or model components unrelated to the data.
10	MC	Relate the validity/accuracy of a model to the quality or quantity of supporting evidence. [Which evidence from the data table would support the claim that the carbon cycle model is accurate?]	Key may focus on aspects of the evidence that validate or provide greater accuracy to the model. Distractors may include data that relate to broader processes/relationships but do not support the claim or central concept.
11	TEI	Construct or complete a model of carbon cycling based on photosynthesis and/or cellular respiration processes. [Complete the carbon flow model for an ocean biome to show the processes that occur to transfer carbon.]	Drag-drop interaction. Correct responses show components, processes, and interactions correctly indicated. Partial credit would be awarded for a subset of correct responses.

Student Misconceptions:

*Response options can make use of Student Misconceptions (examples of scientifically incorrect assumptions) related to this performance expectation; references to misconceptions are listed below:

From energyeducation.eku.edu/sites/energyeducation.eku.edu/files/energyFlowinEcologicalSystems.pdf:

- Plants take in food from the outside environment, and/or plants get their food from the soil via roots.
- Energy cannot be created or destroyed.
- Carbon dioxide is a source of energy for plants.

Ecosystems: Interactions, Energy, and Dynamics: B.LS2.6

back to “Item Specifications by Performance Expectation”

B.LS2.6. Evaluate the claims, evidence, and reasoning that the complex interactions in ecosystems maintain relatively consistent numbers and types of organisms in stable conditions, but changing conditions may result in a new ecosystem.

OAS-S Clarification Statement:

Examples of changes in ecosystem conditions could include modest biological or physical changes, such as moderate hunting or a seasonal flood; and extreme changes, such as volcanic eruption or sea level rise.

OAS-S Assessment Boundary:

The assessment should provide evidence of students’ abilities to derive trends from graphical representations of population trends. Assessments should focus on describing drivers of ecosystem stability and change, not on the organismal mechanisms of responses and interactions.

Science & Engineering Practice:	Disciplinary Core Idea:	Crosscutting Concept:
<p>Engaging in Argument from Evidence</p> <ul style="list-style-type: none"> Evaluate the claims, evidence, and reasoning behind currently accepted explanations or solutions to determine the merits of arguments. 	<p>Ecosystem Dynamics, Functioning, and Resilience</p> <ul style="list-style-type: none"> A complex set of interactions within an ecosystem can keep its numbers and types of organisms relatively constant over long periods of time under stable conditions. If a modest biological or physical disturbance to an ecosystem occurs, it may return to its more or less original status (i.e., the ecosystem is resilient), as opposed to becoming a very different ecosystem. Extreme fluctuations in conditions or the size of any population, however, can challenge the functioning of ecosystems in terms of resources and habitat availability. 	<p>Stability and Change</p> <ul style="list-style-type: none"> Much of science deals with constructing explanations of how things change and how they remain stable.

In Lay Terms:

Students should be able to evaluate the strength of arguments about how stability is maintained or disrupted in ecosystems based on data provided. Under most circumstances environmental factors ensure that a natural continuity is maintained, but more extreme changes to one or more of these factors can result in major ecosystem changes.

Cluster Clarifications:

- To address the CCC, stimuli and items should address factors regarding stability and change of populations and resulting diversity in ecosystems.

Ecosystems: Interactions, Energy, and Dynamics: B.LS2.6

Cluster Stimulus Attributes:

Typical stimulus elements:

- claims, evidence, and/or reasoning presented as text, models, and/or graphical charts/diagrams

Possible contexts:

- investigations of which type of succession occurs based on degree of ecological disturbance
- comparisons of primary and secondary succession
- descriptions or computer models demonstrating characteristics and/or minimal flux of a climax community over long periods of time
- population changes caused by ecological disturbance in an ecosystem
- the non-static way in which a community re-establishes after an ecological disturbance
- graphical representations and case studies used as references to evaluate and predict future changes within an ecosystem
- assessments and/or comparisons of modest and extreme fluctuations in conditions of ecosystems

Content and evidence to be included: claims and a given amount of evidence and/or reasoning about interactions or conditions that either maintain or disturb ecosystem stability

Types of student responses that need to be supported: evaluating claims in order to determine strength of claim, quality of evidence, appropriate reasoning, and additional evidence or revisions to the claims

Allowable Item Types:

- MC
- TEI

Model Item Descriptions for B.LS2.6:

#	Item Type	Model Stem (Items ask students to...)	Response Characteristics*
1	MC	Identify or describe the reasoning that best supports the claim/conclusion for an ecosystem change. [Which reasoning best supports the scientists' claim about the type of ecological disturbance that caused primary succession (or secondary succession) in the forest community?]	Key should focus on reasoning from information and content provided in stimulus plus knowledge of the DCI. Distractors may include invalid or unsupported reasoning.
2	MC	Compare claims to evaluate which claim (about ecosystem continuity or change based on a disturbance) is best supported by the data. [Which claim made by the students about the succession model after the flood is best supported by the data?]	Key may focus on distinguishing/using data showing an ecosystem response to the same or a similar disturbance. Distractors may include unsupported claims or claims based on reasoning not included in or not relevant to the data.
3	MC	Evaluate the merit of a claim about the stability of an ecosystem based on data evidence. [Which statement best describes the (strength of the) claim made about the stability of the forest ecosystem after the fire?]	Key may focus on the degree of stability (normal fluctuation versus significant change) supported by the data evidence. Distractors may include unsupported claims or claims about effects not related to the disturbance event.
4	MC	Identify evidence that supports a claim or an argument for what event(s) caused an ecosystem change. [What evidence supports the student's claim that a new ecosystem formed because of overgrazing?]	Key should focus on data supporting the claim or argument. Distractors may include unrelated or insignificant data.
5	MC	Identify the argument that best rejects the claim for ecosystem stability based on the evidence. [Which argument best rejects the claim that a new ecosystem resulted from the fire?]	Key should focus on an argument for a counterclaim based on the evidence. Distractors may include arguments not based on evidence or unsupported by the evidence.
6	MC	Identify additional evidence that would support the claim that a particular event may cause an ecosystem to maintain or shift stability (e.g., undergo succession). [Which additional evidence would support the scientists' claims that succession happens in the forest community after clear-cutting of timber?]	Key may focus on evidence specific to the data (e.g., populations of nesting birds decreased by 40% after the clear-cutting) or more general data/evidence needed (e.g., evidence about how increased light favors certain tree species). Distractors may include added evidence that does not support the claim.
7	MC	Distinguish the evidence and/or reasoning from evidence that best improves/supports the scientific reliability of an argument or conclusion about ecosystem stability. [Which evidence and reasoning would improve the reliability of the scientists' explanation of which plants are dominant at which stage of succession?]	Key may focus on data/reasoning that offers better control of variables, support from additional studies, or repetition of the investigation. Distractors may include evidence or reasoning that does not improve the reliability or evidence unrelated to the argument/ conclusion.

#	Item Type	Model Stem (Items ask students to...)	Response Characteristics*
8	MC	Revise a claim about the stability/instability of an ecosystem based on evidence from a study or an observation. [Which revised claim about the ecosystem best reflects the data from the new study?]	Key may focus on additional or alternative statements incorporating the impact of the new evidence. Distractors may include unsupported/unrelated revisions or revisions contradicted by the evidence.
9	MC	Explain the relative merit, supporting evidence, and reasoning for comparing and ranking claims about changes in an ecosystem. [Which of the scientists' claims about the impact of warmer temperatures on the grassland ecosystem is better supported, and why?]	Explanation/analysis must be included, as compared to model stem #2. Key may focus on merit due to better data support or reasoning. Distractors may include incorrect conclusions and justifications based on invalid interpretation of the data and/or misconceptions.
10	TEI	Distinguish between the merits of various claims about ecosystem stability based on the evidence that supports each claim. [Match each claim to the data that best supports that claim.]	Match interaction. Interaction direction text should specify whether all choices will be matched (extraneous or irrelevant data may be included in data choices). Correct responses show all correct associations between the claims and the data. Partial credit would be awarded for a subset of correct responses.

Student Misconceptions:

*Response options can make use of Student Misconceptions (examples of scientifically incorrect assumptions) related to this performance expectation; references to misconceptions are listed below:

- Species coexist in an ecological system because of their compatible needs and behaviors; they need to get along.
- Ecosystems are not a functioning whole, but simply a collection of organisms.
- Communities change little over time.
- The number of producers is high to satisfy consumers (i.e., producers and food organisms exist because the organisms above them in the food web need food).

Students may also believe the following:

- Humans can easily and permanently change any ecosystem to suit their needs.
- Ecological disturbances always cause permanent and irreversible change in ecosystems.
- Organisms inhabit certain habitats and ecosystems by preference rather than to fill a niche.

Ecosystems: Interactions, Energy, and Dynamics: B.LS2.8

back to “Item Specifications by Performance Expectation”

B.LS2.8. Evaluate evidence for the role of group behavior on individual and species’ chances to survive and reproduce.

OAS-S Clarification Statement:

Emphasis is on advantages of grouping behaviors (e.g., flocking, schooling, herding) and cooperative behaviors (e.g., hunting, migrating, swarming) on survival and reproduction.

OAS-S Assessment Boundary:

The assessment should provide evidence of students’ abilities to: (1) distinguish between group versus individual behavior, (2) identify evidence supporting the outcomes of group behavior, and (3) develop logical and reasonable arguments based on evidence.

Science & Engineering Practice:	Disciplinary Core Idea:	Crosscutting Concept:
Engaging in Argument from Evidence <ul style="list-style-type: none"> Evaluate the claims, evidence, and reasoning behind currently accepted explanations or solutions to determine the merits of arguments. 	Social Interactions and Group Behavior <ul style="list-style-type: none"> Group behavior has evolved because membership can increase the chances of survival for individuals and their genetic relatives. 	Cause and Effect <ul style="list-style-type: none"> Empirical evidence is required to differentiate between cause and correlation and make claims about specific causes and effects.

In Lay Terms:

Students should be able to evaluate and critique scientific claims, evidence, and reasoning from data used to explain the group behaviors of animals in response to factors limiting survival. For example, many herbivore prey species demonstrate herding behavior. Herding may increase the chance of the individual animal to survive due to enabling the species as a whole to become more efficient at finding food, avoiding danger, and reproducing.

Cluster Clarifications:

- To address the CCC, stimuli and items should contain empirical evidence relating to claims, arguments, or reasoning that allow students to differentiate cause and/or correlation and observed effects.

Cluster Stimulus Attributes:

Typical stimulus elements:

- research results in the form of text summaries/conclusions, tables, graphs, and maps

Possible contexts:

- scientific investigations that provide examples of group behaviors that impact species survival
- analysis/comparisons of research findings about the group behaviors of animals in varying environments/conditions
- discoveries of additional data/evidence that supports claims or reasoning for group behavior influences on survival rates
- evaluations of the validity, strengths, and weaknesses of available evidence for the advantages/disadvantages of group behavior
- analysis/comparisons of evidence and arguments/conclusions from investigations of group versus individual behavior, including survival or population measures

Content and evidence to be included: data, information, and/or claims about relationships between animal behaviors (group and/or individual) and survival, reproduction, or population measures; sufficient evidence to help distinguish cause and correlation in relationships

Types of student responses that need to be supported: evaluating claims, evidence, and reasoning from the data presented

Allowable Item Types:

- MC
- TEI

Model Item Descriptions for B.LS2.8:

#	Item Type	Model Stem (Items ask students to...)	Response Characteristics*
1	MC	<p>Identify which evidence best supports a claim about why a group behavior can benefit the species (survival and/or reproduction).</p> <p>[Which evidence supports the scientists' claim about herding behavior in bison?]</p> <p>[Which data show that cooperation of males and females in cardinal nesting improves the species' survival chances?]</p>	<p>Key may focus on the evidence linking the behavior and a survival benefit.</p> <p>Distractors may include incorrect evidence or evidence that only partially supports the claim.</p>
2	MC	<p>Describe/differentiate causal relationships (rather than correlation) based on reasoning from data about how a behavior benefits group survival.</p> <p>[Which statement best describes what the data show about how monarch butterfly migration influences their survival?]</p>	<p>Key should focus on <u>causal</u> relationship between the behavior, and reasoning based on data evidence of a survival benefit.</p> <p>Distractors may include the incorrect relationship or the wrong reasoning for the relationship.</p>
3	MC	<p>Describe/develop reasoning for why a particular behavior (e.g., rearing of young individually or as a group) contributes to species survival.</p> <p>[Which statement about mammal versus bird rearing of young is best supported by the data from the two studies?]</p>	<p>Key may focus on the supportive link between the data and the reasoning presented.</p> <p>Distractors may include statements that incorrectly reason from the data or fail to have support for the reasoning.</p>
4	MC	<p>Explain the merit of evidence supporting a claim for why group behavior provides an advantage for preserving resources that increase the species' chance of survival.</p> <p>[Which evidence best supports the claim that bees benefit from building and defending a hive, and why does it best support the claim?]</p>	<p>An explanation/analysis must be required to distinguish from model stem #1.</p> <p>Key should focus on the validity of the explanation based on the evidence in the data.</p> <p>Distractors may include erroneous evaluations of the merit of the evidence or may evaluate aspects of the evidence unrelated to its merit.</p>
5	MC	<p>Explain why a claim made from evidence about a group or an individual behavior pattern is due to correlation rather than cause and effect.</p> <p>[Which statement explains why the relationship between the whitetail deer behavior and survival rates is correlation?]</p>	<p>Key must focus on correlation and the evidence that supports this relationship (lack of evidence of cause-effect).</p> <p>Distractors may include insufficient or invalid explanations.</p>
6	MC	<p>Critique the reasoning for a scientific claim about the relationship between behavior and reproductive rates (e.g., hunting behavior and reproductive rates of a predator species).</p> <p>[Which statement evaluates the reasoning for the claims made by scientists based on the data for the three wolf populations?]</p>	<p>Key may focus on the match between the data, claim, and underlying concept, as well as the direction relationship supported or not supported.</p> <p>Distractors may include faulty evaluation of reasoning, emphasizing reasoning unrelated to the claims, or reasoning supporting aspects of the claims unrelated to the link between the data and claim.</p>

#	Item Type	Model Stem (Items ask students to...)	Response Characteristics*
7	MC	Identify evidence from the data that rejects an argument related to a behavior and survival rates. [Which data provides evidence that would reject the student’s claim about the schooling of menhaden?]	Key may focus on data that counter the premise or reasoning for the argument. Distractors may include data that support or are irrelevant to the argument, or data that refute a different argument.
8	MC	Determine which evidence from the data supports a cause-effect relationship rather than a correlation between a species’ behavior and a survival advantage. [Which data show that the link between the herding instinct of antelope and their increased survival is a cause-effect relationship and not a correlation?] [Which of these data best support the argument made by the scientist that the benefit of cooperative hunting to the wolf species is a cause-effect relationship and not correlation?]	Key may focus on specific data that link the cooperative behavior and the survival advantage. Distractors may include evidence that supports correlation instead of cause-effect or that supports neither relationship.
9	TEI	Distinguish correlation from causation in examples of species’ behavior patterns and provide reasoning to support each choice. [Using the data from the study, classify the relationship between each group behavior and its benefit, and label each relationship as causation or correlation.]	Drag-drop, drop-down, or match interaction. Reasoning associations may be incorporated in some items. Correct responses show proper associations between behaviors (e.g., cooperative hunting), benefits (e.g., increased reproduction, increased survival), and correlation vs. causation. Partial credit would be awarded for a subset of correct responses.

Student Misconceptions:

*Response options can make use of Student Misconceptions (examples of scientifically incorrect assumptions) related to this performance expectation; references to misconceptions are listed below:

- Students misunderstand the meaning of the terms “adapt” and fitness (e.g., students think adapt means to resist or withstand rather than change in response to selection; they think fitness means the ability to do physically demanding tasks or having good general health rather than having favorable characteristics).
- Students do not understand the amount of cause of genetic variation among organisms (e.g., students think all genetic variation is due to mutation or due to environmental factors).

From www.tandfonline.com/doi/abs/10.1080/00958964.1994.9941962#.VPpv-uEpvm4:

- Adaptation occurs due to individual needs (or will to change) (i.e., Lamarck’s theory).
- In all selection fitness is a function of the bigger and stronger organisms.
- All members of a species are very similar and there is little variation within species or populations.

Heredity: Inheritance and Variation of Traits: B.LS3.1

back to “Item Specifications by Performance Expectation”

B.LS3.1. Ask questions to clarify relationships about the role of DNA and chromosomes in coding the instructions for characteristic traits passed from parents to offspring.

OAS-S Clarification Statement:

Emphasis is on the use of models of DNA to formulate questions, the answers to which would clarify the cause and effect relationships (including distinguishing between causal and correlational relationships) between DNA, the proteins it codes for, and the resulting traits observed in an organism.

OAS-S Assessment Boundary:

Assessment does not include the phases of meiosis or the biochemical mechanism of specific steps in the process.

Science & Engineering Practice:

Asking Questions

- Ask questions that arise from examining models or a theory, to clarify and/or seek additional information and relationships.

Disciplinary Core Idea:

Structure and Function

- All cells contain genetic information in the form of DNA molecules.
- Genes are regions in the DNA that contain the instructions that code for the formation of proteins, which carry out most of the work of the cells.

Inheritance of Traits

- Each chromosome consists of a single, very long DNA molecule, and each gene on the chromosome is a particular segment of that DNA.
- The instructions for forming species’ characteristics are carried in DNA. All cells in an organism have the same genetic content, but the genes used (expressed) by the cell may be regulated in different ways.
- Not all DNA codes for protein; some segments of DNA are involved in regulatory or structural functions, and some have no, as of yet, known functions.

Crosscutting Concept:

Cause and Effect

- Empirical evidence is required to differentiate between cause and correlation and make claims about specific causes and effects.

In Lay Terms:

Students should be able to ask questions and make predictions about the role of chromosomes and DNA in the inheritance of traits. Inheritance of traits in observable patterns occurs because DNA instructions carried on segments of chromosomes called genes are passed from parents to offspring during reproduction. By studying patterns of inheritance, characteristic functions of genes can be learned and the likelihood of traits occurring in offspring can be predicted.

Cluster Clarifications:

- To address the CCC, stimuli and items should contain empirical evidence (in a model, explanation, etc.) relating to claims regarding cause and/or correlation and observed effects.

Heredity: Inheritance and Variation of Traits: B.LS3.1

Cluster Stimulus Attributes:

Typical stimulus elements:

- research results/conclusions in the form of text summaries/conclusions, tables, and/or graphs
- models (e.g., Punnett squares)

Possible contexts:

- scientific investigations that provide examples of patterns of inheritance in both sexual and asexual reproduction
- analysis/comparisons of ratios of traits in offspring for the purpose of establishing inheritance patterns
- application of mathematical models (i.e., Punnett squares) to predict the likely inheritance of traits with known inheritance patterns (dominant-recessive, codominant, incompletely dominant, sex-linked)
- evaluations of claims about inheritance based on evidence of parent and offspring genotypes and phenotypes
- analysis/evaluations of evidence, predictions, and claims regarding the heritability of observed characteristics based on genetic evidence (i.e., whether characteristics are heritable/inherited and why or why not)

Content and evidence to be included: data, models, and other information showing inheritance patterns, inherited vs. non-inherited traits, etc.

Types of student responses that need to be supported: stating questions and predictions, along with evidence-based rationales, derived from text, tables, graphs, and/or diagrams

Allowable Item Types:

- MC
- TEI

Model Item Descriptions for B.LS3.1:

#	Item Type	Model Stem (Items ask students to...)	Response Characteristics*
1	MC	Identify which question about heritability of a trait can be answered by examining evidence from a Punnett square, pedigree, or karyotype. [Based on the data, which question about soybean plants can be answered by using a karyotype comparing the varieties of soybeans?]	Key may focus on questions about inheritance patterns identifiable through examination of DNA similarities, generational inheritance patterns, or predictive models/analysis based on parent genotype. Distractors may include inheritance patterns not identifiable by examination of three generation phenotypes or characteristics that are not heritable.
2	MC	Identify a question that tests the conclusion or claim that a characteristic can be inherited. [Which question about the claim can be answered by observing the offspring characteristics?]	Key may focus on heritability or a specific genetic inheritance pattern. Distractors may include questions that do not address the premise of the claim or that do not demonstrate heritability of the characteristic.
3	MC	Predict the traits (disorders or common traits) of offspring based on their parents (genotypes, phenotypes, chromosome code). [Which group of children is most likely to demonstrate the AB blood type trait?] [Which traits will all of the bull's offspring likely have as adult cattle?]	Key may focus on the distinctive inheritance of a trait in preference to other traits or on patterns of inheritance in offspring that demonstrate the predictable heritability. Distractors may include traits or offspring less likely to inherit or unable to inherit the specified trait.
4	MC	Identify which evidence is needed to address a question about the likelihood of inheritance of a trait based on the parents' genotypes. [Which evidence is needed to answer the student's question about why none of the first generation of offspring will have the white coat color trait?]	Key may focus on the evidence linking the parents' genotype to the possible allele combinations that may produce the trait. Distractors may include the wrong evidence or evidence that only partially answers the question.
5	MC	Identify questions that would differentiate between cause and correlation based on reasoning from data about the heritability of a trait. [Which question would identify whether the distribution of the curled leaf characteristic is due to correlation or to a cause-effect relationship?]	Key may focus on causation due to inheritance from parents to offspring and reasoning based on data evidence for this link. Distractors may include the incorrect relationship or the wrong reasoning for the relationship.
6	MC	Identify which of two or more questions or predictions is best supported by the data evidence (and explain reasoning for why). [Which inheritance question asked by the two student groups can more accurately be answered from the data gathered?]	Key may focus on the supportive link between the data and the question/prediction presented. Distractors may include statements that incorrectly reason from the data or fail to have a preponderance of support for the reasoning.
7	MC	Evaluate whether a question or prediction can be addressed with the information/evidence provided and/or whether the question will clarify/extend understanding of the topic. [Which statement is the best evaluation of the students' prediction about the coat color of a colt born from the roan mare?]	Key should focus on the quality of the question and potential to be answered and/or provide useful information (related to DCI content). Distractors may include misconceptions and/or invalid reasoning for the merit of a particular question.

#	Item Type	Model Stem (Items ask students to...)	Response Characteristics*
8	MC	Identify which question will provide the best evidence to support a specific cause-effect relationship (i.e., which inheritance pattern applies). [Which of these questions will provide the best evidence that pod color is caused by dominant-recessive inheritance?]	Key should focus on questions eliciting data that show a specific cause-effect relationship due to a predictable inheritance pattern. Distractors may include questions that will not elicit data/observations to provide evidence for a genetic cause-effect relationship, such as observations of other crosses, different populations, other traits, etc.
9	TEI	Sort questions that allow students to distinguish correlation from causation. [Using the data from the study, classify questions related to pedigrees, percent traits/phenotypes, etc., as being able to distinguish correlation or causation with the data gathered in answering the question.]	Drag-drop, drop-down, or match interaction. Reasoning associations may be incorporated in some items. Correct responses show proper classifications for questions distinguishing correlation vs. causation. Partial credit would be awarded for a subset of correct responses.

Student Misconceptions:

*Response options can make use of Student Misconceptions (examples of scientifically incorrect assumptions) related to this performance expectation; references to misconceptions are listed below:

- The information in the DNA molecules of an organism does not affect the functions of an organism's cells or the physical characteristics of the organism.
- Genes are traits.
- The timing of the occurrence of an environmentally induced characteristic will affect whether the characteristic is transmitted to offspring (i.e., the age at which an organism acquires an environmentally induced characteristic will affect whether the characteristic is passed on to its offspring). For example, if a father lost a finger as a child, he will pass the missing finger trait to his children, but if he lost his finger as an adult he will not pass the missing finger to his children.

From www.carolina.com/teacher-resources/Interactive/5-common-misconceptions-in-genetics/tr10631.tr:

- Students often confuse genetic terms (e.g., chromosomes are genes, chromosomes and genes are traits).
- A dominant trait is the most likely to be found in the population (and recessive traits are expressed to a lesser degree than dominant traits).

Students may also believe the following:

- All characteristics of organisms are traits (heritable).

Heredity: Inheritance and Variation of Traits: B.LS3.2

back to “Item Specifications by Performance Expectation”

B.LS3.2. Make and defend a claim based on evidence that inheritable genetic variations may result from: (1) new genetic combinations through meiosis, (2) viable errors occurring during replication, and/or (3) mutations caused by environmental factors.

OAS-S Clarification Statement:

Emphasis is on using data to support arguments for the way variation occurs.

OAS-S Assessment Boundary:

Assessment does not include the phases of meiosis or the biochemical mechanisms of specific steps in the process.

Science & Engineering Practice:	Disciplinary Core Idea:	Crosscutting Concept:
<p>Engaging in Argument from Evidence</p> <ul style="list-style-type: none"> Make and defend a claim based on evidence about the natural world or the effectiveness of a design solution that reflects scientific knowledge and student-generated evidence. 	<p>Variation of Traits</p> <ul style="list-style-type: none"> In sexual reproduction, chromosomes can sometimes swap sections during the process of meiosis (cell division), thereby creating new genetic combinations and thus more genetic variation. Although DNA replication is tightly regulated and remarkably accurate, errors do occur and result in mutations, which are also a source of genetic variation. Environmental factors can also cause mutations in genes, and viable mutations are inherited. Environmental factors also affect expression of traits, and hence affect the probability of occurrences of traits in the population. Thus the variation and distribution of traits observed depends on both genetic and environmental factors. 	<p>Cause and Effect</p> <ul style="list-style-type: none"> Empirical evidence is required to differentiate between cause and correlation and make claims about specific causes and effects.

In Lay Terms:

Students should be able to make and defend claims about how variations in DNA sequences and environmental factors may affect the expression of traits in organisms and result in multiple sources of variation with populations. Variation in individuals can result from different combinations of the genetic material of parents. Individual variation can also be caused by errors made while cells are copying genetic material (DNA). Cells have mechanisms to check for mistakes, but some mistakes go undetected or uncorrected. Environmental factors, such as temperature, ultraviolet light, and exposure to certain chemicals, may cause individual variation.

Cluster Clarifications:

- To address the CCC, stimuli and items should contain empirical evidence relating to claims or reasoning.

Heredity: Inheritance and Variation of Traits: B.LS3.2

Cluster Stimulus Attributes:

Typical stimulus elements:

- models showing crossing over/mutation/replication error examples
- tables containing data related to variations and offspring genotype/phenotype or gene/chromosome/mutation frequency
- text descriptions of experimental designs/procedures/results

Possible contexts:

- models that demonstrate how meiosis leads to genetic variation due to random assortment
- diagrams depicting crossing over of chromosomes during meiosis
- graphics that represent coding errors during replication
- research, investigation, and data that indicate genetic variations resulting from environmental factors
- data that identify patterns in DNA replication errors

Content and evidence to be included: models/diagrams, graphs, and scientific investigation scenarios to provide data for claims, evidence, and reasoning

Types of student responses that need to be supported: making, evaluating, and/or revising claims, with evidence and reasoning based on data and models related to sources and expressions of genetic variation

Allowable Item Types:

- MC
- TEI

Model Item Descriptions for B.LS3.2:

#	Item Type	Model Stem (Items ask students to...)	Response Characteristics*
1	MC	Using a meiosis/chromosome model and data for variation in offspring, identify which claim explaining how meiosis leads to genetic variation is supported by the evidence.	Key may focus on recombination (independent assortment) or crossing over outcomes. Distractors may include explanations of results not related to the meiosis process or explanations of outcomes not related to variation.
2	MC	Using data that illustrate patterns in DNA replication and possible errors, make, defend, or reject a claim regarding the probable effect on offspring. [Based on the replication pattern shown in the data, how will the offspring of this parent cell be affected?]	Key may focus on the appearance, effect, or distribution of results of replication errors on offspring. Item may be in the context of sexual or asexual reproduction (and distinguishing how the mutation will/will not be passed on.) Distractors may include patterns or combinations that have no effect or do not have the specified effect, or on claims that are unsupported.
3	MC	Identify or describe the data support or reasoning for a claim, using evidence about environmental factors that influence genetic variation. [Which data from the study of the mosquitoes' resistance support the claim made by the students?]	Key may focus on the most relevant variable and results that support the claim presented. Distractors may include data/reasoning that does not support the claim or that provides only partial support of the claim.
4	MC	Identify or describe the reasoning from investigative evidence that best supports the claim/conclusion for a result of a new genetic combination in offspring or succeeding generation(s). [Based on the research data, which reasoning best supports the scientists' claim about the effect of independent assortment on the goose population?]	Key may focus on reasoning from empirical data supporting a redistribution of traits in offspring/F ₂ generations. Distractors may include invalid or unsupported reasoning.
5	MC	Identify or evaluate data support for a claim about predicted results of a cross based on a model of crossing over during meiosis. [Based on the crossing over model, which statement best describes the data support for the students' claim regarding the cross of the two parents (one parent having the given trait)?]	Key may focus on relevant data showing the appearance rate or frequency of traits resulting from crossing over in populations or generations. Distractors may include unsupported claims or claims based on reasoning not included in or relevant to the data.

#	Item Type	Model Stem (Items ask students to...)	Response Characteristics*
6	MC	<p>Identify empirical evidence that supports a claim for what genetic event <u>caused</u> the appearance or redistribution of a trait in a population or succeeding generations.</p> <p>[What statement best describes the evidence that supports the student’s claim that the deleterious mutation was the result of a replication error?]</p> <p>[Which reasoning best supports the scientists’ claim about the origin of the mutation in the second and third generations?]</p>	<p>Key may focus on data supporting the claim or reasoning for the claim (using data evidence/ stimulus information and knowledge of the DCI).</p> <p>Distractors may include unrelated or insignificant data.</p>
7	MC	<p>Identify the evidence that best rejects a claim for the influence of the environment on the expression of a trait.</p> <p>[Which evidence best rejects the claim that temperature is not a significant factor that determines the coat color of the snowshoe hare?]</p>	<p>Key may focus on data support for a counterclaim based on the evidence.</p> <p>Distractors may include evidence not based on the data or unsupported by the data.</p>
8	MC	<p>Identify additional evidence that would support the claim that an environmental factor caused a viable gene mutation.</p> <p>[Which additional evidence would support the student’s claim that ultraviolet radiation caused a mutation in the bacteria’s DNA?]</p>	<p>Key may focus on evidence that is specific to the data (e.g., mutation rates increased by 5% while other variables did not change) or more general data/evidence needed (e.g., evidence about mutation rate vs. other measures/ variables).</p> <p>Distractors may include other information/ data that do not support the claim.</p>
9	MC	<p>Distinguish the evidence and/or reasoning from evidence that best improves/supports the scientific reliability of a claim related to variation caused by a meiosis process.</p> <p>[Which evidence and reasoning would improve the claim made by the students about the source of the variation in the fruit fly populations?]</p> <p>[Which evidence and reasoning would improve the reliability of the scientists’ claim about why meiosis contributes to the variation in Amazon guppies?]</p>	<p>Key may focus on data/reasoning that offers better control of the variables, support from additional studies, or repetition of the investigation.</p> <p>Distractors may include evidence/reasoning that does not improve the reliability or evidence unrelated to the claim.</p>
10	MC	<p>Revise a claim about the mechanism by which a trait is passed based on evidence from a study/observation.</p> <p>[How should the claim (about how the trait was passed from parent rats to baby rats) be revised based on data from the study?]</p>	<p>Key may focus on additional or alternative statements incorporating the impact of the new evidence on the original claim.</p> <p>Distractors may include unsupported/ unrelated revisions or revisions contradicted by the evidence.</p>

#	Item Type	Model Stem (Items ask students to...)	Response Characteristics*
11	MC	Compare multiple claims about varied inheritance of DNA via meiotic processes or mutations in terms of their accuracy, supporting evidence, and/or reasoning for the claims. [Which of the scientists' claims about the impact of mutations on the genetic variation in the population is better supported and why?]	Key may focus on merit due to better data support or reasoning. Distractors may include incorrect identification of the more supported claim and/or claim support inconsistent with the evidence or logical reasoning.
12	TEI	Compare multiple claims about varied inheritance of DNA via meiotic processes or mutations in terms of their accuracy, supporting evidence, and/or reasoning for the claims. [Order the three claims from best to least supported by the data.]	Drag-drop interaction. Correct responses show claims in specified order. Partial credit would be given for prioritized portions of the sequences (e.g., able to distinguish which claim is most supported).
13	MC	Identify evidence that supports a claim for the occurrence of crossing over based on two comparative lines of offspring. [What evidence supports the student's claim that crossing over occurred in population #2?]	Key may focus on data that show traits controlled by genes on the same chromosome being inherited in a pattern that does not resemble either parent's gene pattern. Distractors may include unrelated or insignificant data.

Student Misconceptions:

*Response options can make use of Student Misconceptions (examples of scientifically incorrect assumptions) related to this performance expectation; references to misconceptions are listed below:

- The information in the DNA molecules of an organism does not affect the functions of an organism's cells or the physical characteristics of the organism.
- Genes are traits.
- The timing of the occurrence of an environmentally induced characteristic will affect whether the characteristic is transmitted to offspring (i.e., the age at which an organism acquires an environmentally induced characteristic will affect whether the characteristic is passed on to its offspring). For example, if a father lost a finger as a child, he will pass the missing finger trait to his children, but if he lost his finger as an adult he will not pass the missing finger to his children.

From www.carolina.com/teacher-resources/Interactive/5-common-misconceptions-in-genetics/tr10631.tr:

- Students often confuse genetic terms (e.g., chromosomes are genes, chromosomes and genes are traits).
- A dominant trait is the most likely to be found in the population (and recessive traits are expressed to a lesser degree than dominant traits).

Students may also believe the following:

- All characteristics of organisms are traits (heritable).

Heredity: Inheritance and Variation of Traits: B.LS3.3*

back to "Item Specifications by Performance Expectation"

B.LS3.3. Apply concepts of statistics and probability to explain the variation and distribution of expressed traits in a population.

OAS-S Clarification Statement:

Emphasis is on distribution and variation of traits in a population and the use of mathematics (e.g., calculations of frequencies based on data from Punnett squares, graphical representations) to describe the distribution of traits in a population, not individuals.

OAS-S Assessment Boundary:

Emphasis is on students' use of genetic models to explain the variation and patterns observed in a population as a combination of genetic and environmental factors. Assessment does not include Hardy-Weinberg calculations.

Science & Engineering Practice:

Analyzing and Interpreting Data

- Apply concepts of statistics and probability (including determining function fits to data, slope, intercept, and correlation coefficient for linear fits) to scientific and engineering questions and problems, using digital tools when feasible.

Disciplinary Core Idea:

Variation of Traits

- Environmental factors also affect expression of traits, and hence affect the probability of occurrences of traits in the population. Thus the variation and distribution of traits observed depends on both genetic and environmental factors.

Crosscutting Concept:

Scale, Proportion, and Quantity

- Algebraic thinking is used to examine scientific data and predict the effect of a change in one variable on another (e.g., linear growth vs. exponential growth).

In Lay Terms:

Students should be able to manipulate and analyze mathematical data to support/explain the effect of genetic inheritance and environmental factors on variation and distribution of traits in populations.

Cluster Clarifications:

- The focus should be on the conceptual understanding rather than knowledge of specific terminology (e.g., directional, stabilizing, disruptive selection; frequency distribution; etc.)
- Algebraic thinking in this context includes interpretation of Punnett square ratios, trends/shifts in population distribution graphs, and interpretation of comparative data for resources/selective factors and trait expression. Students are not actually expected to calculate or identify function fitness, slopes, intercepts, or correlation coefficients (listed in the Science and Engineering Practice dimension).
- In order to address the CCC, stimuli and items should focus on the relationship between independent variables and trait frequency/distribution in an investigative context.

**associated sample cluster included*

Heredity: Inheritance and Variation of Traits: B.LS3.3*

Cluster Stimulus Attributes:

Typical stimulus elements:

- tables, charts, summaries with percentages or ratios (genotypes and/or phenotypes in a population)
- Punnett squares
- graphical representations of directional/stabilizing/disruptive selection
- histograms of species' trait frequencies or distributions
- range distribution maps of species trait variations in populations

Possible contexts:

- literature examples containing descriptions of genotype and phenotype percentages of organisms as they relate to variations and/or environmental conditions
- student investigations of phenomena including mathematical claims based on Punnett squares in contrast to or in combination with environmental data
- scientific studies including graphical representations of examples of directional, stabilizing, or disruptive selection along with information about the function of selective pressure(s)
- student investigations of advantageous/disadvantageous adaptations in changing environments or between contrasting environments for a species of interest
- surveys/summaries of scientific studies regarding the impact of environment/disease/predators/food on the survival of organisms with advantageous/disadvantageous traits and the distribution of those traits as a consequence

Content and evidence to be included: mathematical data about distribution and variation of traits

Types of student responses that need to be supported: analyzing data and making conclusions/supporting explanations about the influence of inheritance and environment on trait distribution according to the data

Allowable Item Types:

- MC
- TEI

Model Item Descriptions for B.LS3.3:

#	Item Type	Model Stem (Items ask students to...)	Response Characteristics*
1	MC	<p>State trends, observations, or direct conclusions about trait variation and distribution as shown by the data/graphs from an investigation.</p> <p>[What trend is shown in the frequency of the coat color of the field mice before and after the introduction of flying drones into the study area?]</p> <p>[Which conclusion is best supported by the graphs of lizard body size versus clutch survival on each island?]</p>	<p>Key may focus on changes/contrasts in percentages, frequency distributions, or ranges of distribution for a trait in a population.</p> <p>Distractors may include statements about the trait(s) or populations that are unrelated to or not supported by the variable relationships in the data.</p>
2	MC	<p>Use empirical data to make a conclusion about cause-effect relationships for trait distribution or variation.</p> <p>[Which environmental factor most likely causes the gray color phase in the western screech owl population?]</p> <p>[Which statement best describes the relationship between habitat type and color variation in the screech owl population?]</p> <p>[Based on the data, what factor is most responsible for the distribution pattern of the different whitetail sub-species shown on the map?]</p>	<p>Key may focus on descriptions of the cause and/or effect illustrated between independent and dependent variables.</p> <p>Distractors may include environmental factors that do not influence the relationship or factors that are not distinctly environmental.</p>
3	MC	<p>Use empirical data to make a conclusion/claim about the degree of variation or distribution of traits.</p> <p>[Which claim about the variation of traits in the owl population is best supported by the probability shown in the Punnett square?]</p>	<p>Key should involve some level of data inference or analysis to distinguish it from model stem #1.</p> <p>Distractors may include claims unsupported by the Punnett square evidence.</p>
4	MC	<p>Describe or explain the relevance of data used to construct an explanation for trait distribution/variation measured in an investigation.</p> <p>[How does the trend shown in the graph (directional selection) help explain the distribution of the gray phase in the owl population?]</p>	<p>Key may focus on how/why the data support or refute the claim/argument made in the explanation.</p> <p>Distractors may include data or explanation elements that are unrelated or irrelevant.</p>
5	MC	<p>Describe, compare, or distinguish the effect of genetic versus environmental factors on a trait.</p> <p>[According to the graph and the Punnett square, which of the following best describes the influence of climate on expression of the gray feather color trait in this screech owl population?]</p>	<p>Key may focus on comparing or distinguishing genetic causation from environmental factor correlation based on the data (as both genetic and environmental factors influence expression).</p> <p>Distractors may include descriptions of effects that do not change expression of the trait or of effects that change the expression of the trait in other ways.</p>

#	Item Type	Model Stem (Items ask students to...)	Response Characteristics*
6	MC	Describe <i>how</i> the data support a given claim or explanation about trait variation or distribution. [How does the change in the distribution of the gray color phase trait in screech owls support the claim that fires became more frequent in the owl's environment after (year)?]	Key may focus on the logical connection between the data and the claim/explanation. Distractors may include statements connecting the trait distribution change erroneously to factors other than the environment or to factors resulting from rather than causing the distribution pattern.
7	MC	Relate the validity or accuracy of statistical data to the reliability of a claim/conclusion about distribution or inheritance of traits. [How does the color phase distribution data affect the reliability of the claim that habitat type affects distribution of this trait in the owl population?]	Key may focus on data measurement or reporting that demonstrates either accuracy/validity or the lack thereof in relation to the claim/conclusion being made. Distractors may include characteristics of the color phase distribution data that do not affect reliability or that affect the reliability of a different claim.
8	MC	Represent or reorganize empirical data in a different form to show trend, frequency, distribution, etc. based on the variables of the investigation. [Which graph illustrates the frequency distribution pattern of the dark versus buff coat color trait shown in the data table?]	Key may focus on converting table data to graphs or map data to tables/charts/graphs. Distractors may include trends, frequencies, or distribution patterns of other data, or may include incorrect patterns or trends.
9	TEI	Represent or reorganize empirical data in a different form to show trend, frequency, distribution, etc. based on the variables of the investigation. [Show the correct frequency distribution graphs and the explanation for each pattern in the correct places on the data chart for both species.]	Drag-drop interaction. Match interaction might alternately be used in some cases. Correct responses show selection/identification/association of correct data representations or transformations. Partial credit would be awarded for a subset of correct responses.
10	MC	Calculate relevant averages, changes, percentage, ratio, etc. to analyze and apply the data from an investigation. [Based on the genetics that determine the seed type of the blue grama grass plant, what is the approximate predicted frequency of awnless seeds in a wild population of blue grama grass?]	Key may focus on calculating averages, percentages, or ratios to determine frequency or distribution patterns of traits in a population. Distractors may include ratios, percentages, comparative values based on common misconceptions, or common application errors.

Student Misconceptions:

*Response options can make use of Student Misconceptions (examples of scientifically incorrect assumptions) related to this performance expectation; references to misconceptions are listed below:

- The information in the DNA molecules of an organism does not affect the functions of an organism's cells or the physical characteristics of the organism.
- Genes are traits.
- The timing of the occurrence of an environmentally induced characteristic will affect whether the characteristic is transmitted to offspring (i.e., the age at which an organism acquires an environmentally induced characteristic will affect whether the characteristic is passed on to its offspring). For example, if a father lost a finger as a child, he will pass the missing finger trait to his children, but if he lost his finger as an adult he will not pass the missing finger to his children.

From www.carolina.com/teacher-resources/Interactive/5-common-misconceptions-in-genetics/tr10631.tr:

- Students often confuse genetic terms (e.g., chromosomes are genes, chromosomes and genes are traits).
- A dominant trait is the most likely to be found in the population (i.e., always more common than recessive traits in a population) (and recessive traits are expressed to a lesser degree than dominant traits).

Students may also believe the following:

- All characteristics of organisms are traits (heritable).
- Expression of traits is controlled only by genes.
- Genetic makeup and the expression of traits can only change through mutation.
- New traits will automatically become more common in a population.
- Organisms act or will themselves to change genetically over time (Lamarck's theory).
- Genes mutate in favorable ways as a response to environmental change.

(Items on the following pages)

Sample Cluster for B.LS3.3:

Use the information to answer the following questions.

Meadow voles are small rodents similar to mice that are found in grassy areas. They store food and give birth to their young in underground burrows. Meadow voles usually have dark fur, but they can sometimes have white fur. Voles with white fur are called albinos. The genetic cause of the albino phenotype is the recessive form of a gene for fur color in voles. The dominant form of the gene codes for dark fur.

Albino voles are typically rare and usually have low survival rates in the population. Scientists recorded the distribution of fur color phenotypes in a vole population in one particular habitat, as shown in the graph.

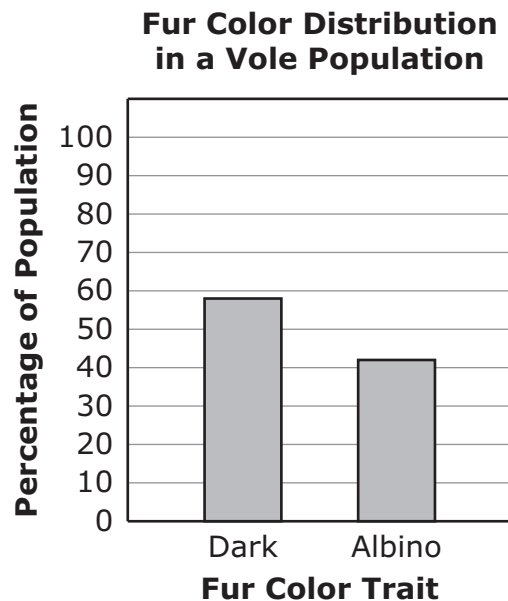

Because the data were not what the scientists expected, they decided to investigate how genetic and environmental factors affect the distribution of expressed traits in vole populations.

Meadow voles are small rodents similar to mice that are found in grassy areas. They store food and give birth to their young in underground burrows. Meadow voles usually have dark fur, but they can sometimes have white fur. Voles with white fur are called albinos. The genetic cause of the albino phenotype is the recessive form of a gene for fur color in voles. The dominant form of the gene codes for dark fur.

Albino voles are typically rare and usually have low survival rates in the population. Scientists recorded the distribution of fur color phenotypes in a vole population in one particular habitat, as shown in the graph.

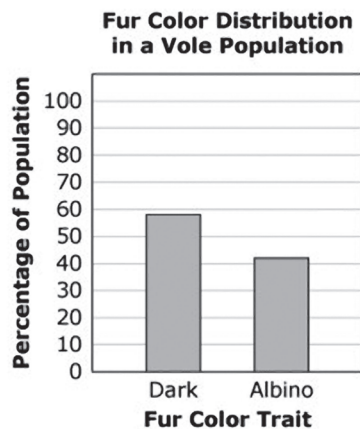

Because the data were not what the scientists expected, they decided to investigate how genetic and environmental factors affect the distribution of expressed traits in vole populations.

Scientists also wondered how another environmental factor, snow, would affect the distribution of fur color in the vole population. They measured survival of dark-furred and albino voles in the winter, after several years with winters that had more snow than usual.

Complete the bar graph to show how the fur color distribution in a vole population would **most likely** change for voles captured under these conditions. Click on the boxes in the graph to create two solid-colored bars with appropriate heights. To select a box, click the box. To deselect a box, click on it again.

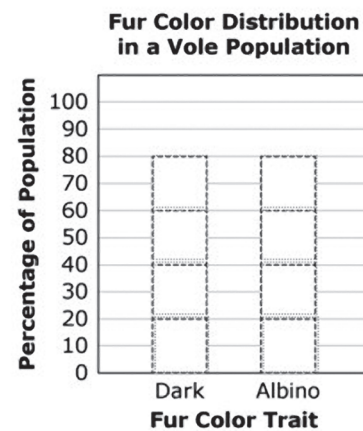

Reset

Pause Test

Standard: Apply concepts of statistics and probability to explain the variation and distribution of expressed traits in a population.

Cognitive Complexity:

SEP: Med

DCI: High

CCC: High

Overall Cognitive Complexity: Low Support

Distractor Rationale:

Correct: More albino voles will most likely be captured since their color will better match the snow than dark-furred voles. The total percentages should combine to 100%.

The student may think that snow will not affect the survival and reproduction of voles.

The student may not understand that the total percentage should be 100%.

Scoring Rubric:

Score	Description
2	2 points for Dark bar showing 40% and Albino bar showing 60% OR Dark bar showing 20% and Albino bar showing 80%
1	1 point for Dark bar showing 20% and Albino bar showing 60% OR Dark bar showing 40% and Albino bar showing 80%
0	0 points for any other combination
Blank	

Sample Response

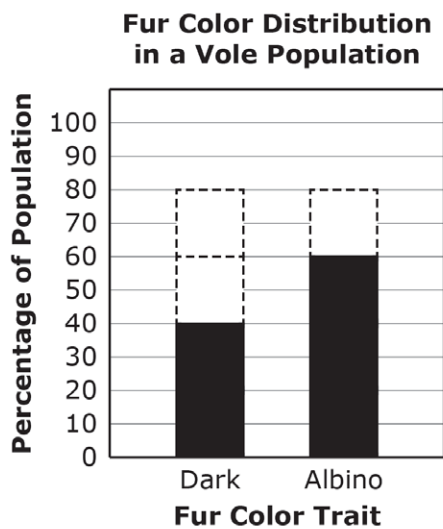

or

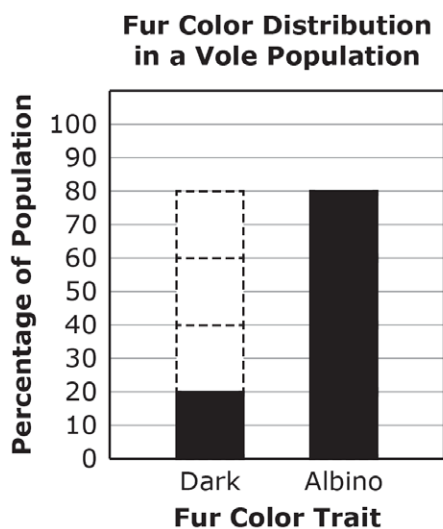

2

When thinking about environmental factors to explain the data in the graph “Fur Color Distribution in a Vole Population,” scientists observed that there were many plants growing close together in the habitat. The scientists hypothesized that the thick plant cover allowed albino voles to be hidden from predators, and that this caused the fur color distribution seen in the vole population.

The scientists set up an experiment to test how the spacing of plants in an area affects the abundance of dark-furred and albino voles. In late spring, scientists released equal numbers of dark-furred and albino voles into habitats with different spacing and numbers of plants. Three months later, they set traps to capture some of the voles remaining in each area.

Which graph shows results that best support the scientists’ hypothesis?

A Effect of Plant Spacing on Vole Abundance

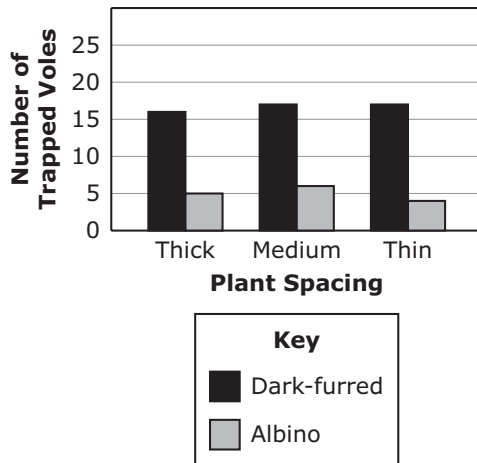

B Effect of Plant Spacing on Vole Abundance

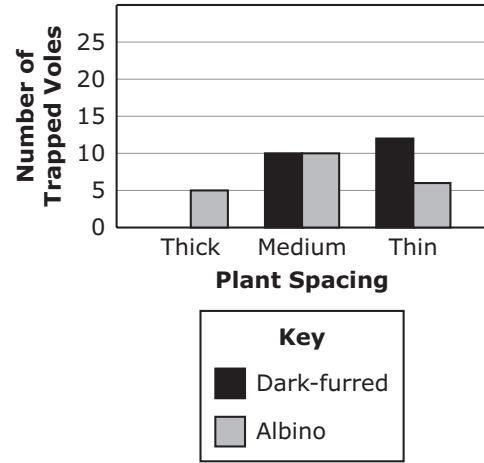

C Effect of Plant Spacing on Vole Abundance

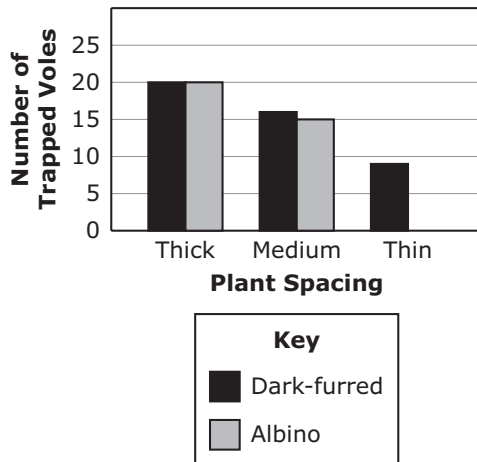

D Effect of Plant Spacing on Vole Abundance

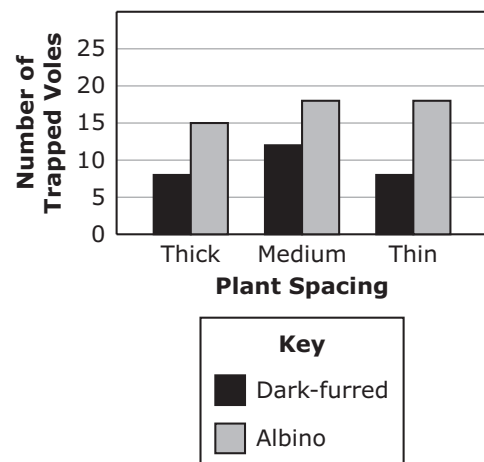

Standard: Apply concepts of statistics and probability to explain the variation and distribution of expressed traits in a population.

Cognitive Complexity:

SEP: Med

DCI: High

CCC: High

Overall Cognitive Complexity: Moderate Support

Distractor Rationale:

- A. The student may think that plant spacing not having a clear effect on the vole population will support the hypothesis.
- B. The student may think that showing a bias against dark-furred voles in thick plant spacing will support the hypothesis.
- C. Correct. The graph shows that albino survival decreases and plant spacing increases.**
- D. The student may think that showing greater numbers of albino voles relative to dark-furred voles supports the hypothesis.

3

Although the environment plays a role in determining the distribution of the fur color trait in the vole population, the percentages of albino voles and voles with dark fur are also influenced by the mating patterns of the voles.

Match each vole cross to its likely outcome to show the expected percentages of offspring with each fur color. To connect a cross and outcome, click the cross and then the outcome, and a line will automatically be drawn between them. To remove a connection, hold the pointer over the line until it turns red, and then click it. You may connect each outcome to more than one vole cross.

Vole cross

AA x AA

Aa x aa

AA x aa

aa x aa

Outcome

50% dark fur and 50% albino fur

100% of offspring with dark fur

100% of offspring with albino fur

Standard: Apply concepts of statistics and probability to explain the variation and distribution of expressed traits in a population.

Cognitive Complexity:

SEP: Low

DCI: Med

CCC: N/A

Overall Cognitive Complexity: Moderate Support

Distractor Rationale:

Correct: The cross AA x AA and AA x aa yields 100% of offspring with dark fur because all offspring will inherit either the AA or Aa genotype. The cross Aa x aa yields 50% of offspring with dark fur and 50% with albino fur because offspring have a 50% chance of inheriting either the Aa or aa genotype. The cross aa x aa yields 100% of offspring with albino fur because all the offspring will inherit the aa genotype.

Incorrect:

The student may not set up the Punnett squares correctly.

The student may not recognize that voles can have dark fur if they inherit either one or two copies of the A allele.

Scoring Rubric:

Score	Description
2	2 points for 4 correct matches
1	1 point for 3 correct matches
0	0 points for 2 or fewer correct matches
Blank	

Sample Response

Vole cross

Outcome

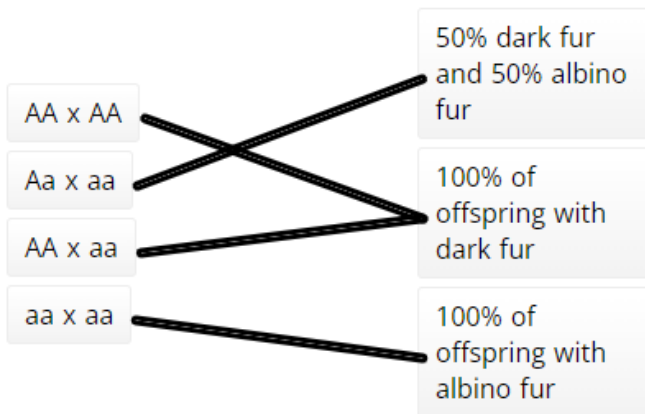

Biological Unity and Diversity: B.LS4.1

back to “Item Specifications by Performance Expectation”

B.LS4.1. Communicate scientific information that common ancestry and biological evolution are supported by multiple lines of empirical evidence.

OAS-S Clarification Statement:

Emphasis is on a conceptual understanding of the role each line of evidence has relating to common ancestry and biological evolution. Examples of evidence should include similarities in DNA and amino acid sequences, but could also include fossil record, anatomical structures, and the order of appearance of structures in embryological development.

OAS-S Assessment Boundary:

Emphasis is on students’ abilities to use evidence such as DNA and amino acid sequences, cladograms, analogous/homologous structures, and fossil records to communicate their understanding of common ancestry and biological evolution.

Science & Engineering Practice:	Disciplinary Core Idea:	Crosscutting Concept:
Obtaining, Evaluating, and Communicating Information <ul style="list-style-type: none">Communicate scientific information (e.g., about phenomena) in multiple formats (including orally, graphically, textually, and mathematically).	Evidence of Common Ancestry and Diversity <ul style="list-style-type: none">Genetic information provides evidence of common ancestry and diversity. DNA sequences vary among species, but there are many overlaps; in fact, the ongoing branching that produces multiple lines of descent can be inferred by comparing the DNA sequences of different organisms. Such information is also derivable from the similarities and differences in amino acid sequences and from anatomical and embryological evidence. Adaptation <ul style="list-style-type: none">Evolution is a consequence of the interaction of four factors: (1) the potential for a species to increase in number, (2) the genetic variation of individuals in a species due to mutation and sexual reproduction, (3) competition for an environment’s limited supply of the resources that individuals need in order to survive and reproduce, and (4) the ensuing proliferation of those organisms that are better able to survive and reproduce in that environment.	Patterns <ul style="list-style-type: none">Different patterns may be observed at each of the scales at which a system is studied and can provide evidence for causality in explanations of phenomena.

In Lay Terms:

Students should be able to communicate information regarding the similarity and differences of form and function of life on Earth. Despite a vast diversity, all organisms share certain characteristics that distinguish them from non-living things.

Biological Unity and Diversity: B.LS4.1

Cluster Clarifications:

- Avoid examples comparing humans to other organisms.
- Time scale, comparative patterns, and causality are important focal points for this performance expectation.

Cluster Stimulus Attributes:

Typical stimulus elements:

- text descriptions of evolutionary patterns/history of organisms' structures, behaviors, and adaptations
- diagrams/photographs of organisms' structures
- data tables, graphs, or models of DNA sequence distributions/patterns
- diagrams/charts/tables that give evidence of organism evolution/relatedness (e.g., cladogram, analogous/homologous structures, fossil records)

Possible contexts:

- comparisons of DNA/amino acid sequences of various organisms to determine degrees of relatedness
- comparisons of characteristics and time scale data for modern species and/or those found in the fossil record to evaluate organism relatedness and evolutionary patterns
- analysis of cladograms along with supporting genetic/physiological evidence to explain common or divergent ancestry
- analysis of vestigial, analogous, homologous, and/or embryological structures to infer patterns of ancestry/evolution

Content and evidence to be included: data regarding various evidence (e.g., DNA sequences, anatomical structures, fossils, development) to analyze in terms of organisms' relatedness and ancestry

Types of student responses that need to be supported: analyzing and interpreting data to describe, explain, and evaluate evidence for relatedness of organisms and biological diversity

Allowable Item Types:

- MC
- TEI

Model Item Descriptions for B.LS4.1:

#	Item Type	Model Stem (Items ask students to...)	Response Characteristics*
1	MC	Analyze similarities/differences in DNA and amino acid sequence evidence among various modern species to determine patterns of origin or diversification over time. [Based on the DNA evidence, which species evolved from the same common ancestor?] [Which conclusion about reptile evolution is best supported by the reptiles' genetic data?]	Key may focus on a pattern showing diversification or similar ancestry based on time scale evidence. Distractors may include incorrect descriptions of patterns or origins/diversity.
2	MC	Analyze and evaluate specific evidence of DNA and amino acid sequences to explain genetic similarities that contrast with variations in physical form among different species. [Which DNA evidence from the study rejects the relationships in the cladogram based on physical similarities?]	Key may focus on how DNA/amino acid evidence contrasts with physical evidence. Distractors may include misinterpretations/misconceptions regarding DNA patterns or incorrect explanations of the evidence.
3	MC	Analyze current data to support explanations of the similarities and differences of organisms illustrated by patterns of genetics, anatomical structures, and embryonic development among species.	This is a broadly focused stem asking for direct comparisons of current data to distinguish relatedness of species/genera. Key may focus on data distinctions that illustrate closeness or gaps in relatedness/evolution of the organisms. Distractors may include incorrect interpretations of patterns or incorrect explanations of organism relationships.
4	MC	Compare evidence of analogous, homologous, and vestigial structures to infer possible origins or ancestral patterns of evolution. [Which relationship shown in the data suggests that whale ancestors once lived on land?] [Which statement about amphibian ancestry is best supported by the structures of the developing frog and fish?]	This stem focuses on comparisons between two data sets for the same organism(s). Key may focus on similarities that illustrate relatedness or common origin/evolution. Distractors may include inferences that are not supported by the data or interpretations of the data that do not infer correct relationships.
5	MC	Analyze cladograms (or other evolutionary models) to describe similarities and differences in the ancestry/origins of species, genera, or families. [Based on the cladogram in study #2, which modern species evolved first?] [Which relationship between modern species is supported by the scientists' evolutionary model?]	Key may focus on correct evaluation of the model to make the necessary distinction of relatedness/diversity. Distractors may include misinterpretations or misconceptions about relationships shown in the model.

#	Item Type	Model Stem (Items ask students to...)	Response Characteristics*
6	MC	<p>Compare species via the time scale of their appearance(s) in the fossil record to support an explanation of similar or different origins/ancestry.</p> <p>[Based on the data table, which model best illustrates the order in which the snail species evolved?]</p> <p>[Which evolutionary relationship between flying birds and flying reptiles is supported by the fossil data?]</p>	<p>Key may focus on fossil evidence to support the order of appearance of organisms, their relatedness, or their evolutionary pathway.</p> <p>Distractors may include misinterpretations or misconceptions about fossil sequences or the superposition logic for the explanation.</p>
7	MC	<p>Identify order or sequence of diagrams to show how an organism changed over time based on empirical evidence of ancestry or evolution.</p> <p>[Which sequence shows the evolution of the horse over time based on the fossil evidence?]</p>	<p>Key may focus on sequences showing progressive evolution in accordance with the data. Data may include time scale, structures, or genetic comparisons as a reference for sequencing.</p> <p>Distractors may include random ordering or ordering based on misinterpretations or misconceptions regarding the evidence.</p>
8	TEI	<p>Order diagrams to show how an organism changed over time based on empirical evidence of ancestry or evolution.</p> <p>[Use the pictures to show how the changes in the organism occurred over time.]</p>	<p>Drag-drop interaction.</p> <p>May also be completed via match or drop-down interaction (to indicate sequence number).</p> <p>Correct responses show accurate selection, placement, and order of organisms. (In some items, student may need to distinguish between options not needed/used).</p> <p>Partial credit would be awarded for a subset of correct responses.</p>
9	MC	<p>Determine the correct position of one or more organisms on a cladogram from provided genetic/fossil data.</p> <p>[Based on the information shown in the data table and diagram, which number on the cladogram represents the most likely position of marine turtles?]</p>	<p>Key may focus on positions distinguished by relationships shown in the data.</p> <p>Distractors may include positions inconsistent with the data.</p>
10	MC	<p>Identify which diagram shows the evolutionary relationships between organisms given data about their genetics/fossils/anatomy.</p> <p>[Based on the evidence provided, which evolutionary tree shows the correct relationships between the organisms?]</p>	<p>Key should show a correct arrangement based on the relatedness/origins shown in the data.</p> <p>Distractors may include combinations of incorrect and correct placements based on misconceptions or erroneous deductions.</p>
11	TEI	<p>Construct a diagram or show the correct position of organisms (two or more) on a cladogram, evolutionary tree, etc. using data about their genetics/fossils/anatomy.</p> <p>[Based on the data, place the four species into their correct positions on the cladogram.]</p>	<p>Drag-drop interaction.</p> <p>May also be completed via match or drop-down interaction (to indicate labeled position).</p> <p>Correct responses show accurate placement of organisms.</p> <p>Partial credit would be awarded for a subset of correct responses.</p>

#	Item Type	Model Stem (Items ask students to...)	Response Characteristics*
12	MC	Interpret data in range or distribution maps of fossil organisms along with genetic/anatomy data to support/reject claims for common ancestry or lines of evolution. [Based on the data shown in the table and the map, which conclusion is best supported about the evolution of flightless birds?]	Key may focus on patterns of evolution reflected in geographic or time scale distribution. Distractors may include misinterpretations or misconceptions relating to the data or its implications.
13	MC	Describe simple patterns and trends in the evolution of a group of organisms based on empirical data. [What pattern is shown in the evolution of hooved mammals?]	Key may focus on traits or characteristics that undergo observable patterns of change through the evolutionary time scale. Distractors may include characteristics/traits of organisms unrelated to the evolutionary pattern/trend.
14	MC	Describe the additional data needed to support a given conclusion about the relatedness or evolution of an organism based on partial data given. [Which additional information would be needed to support the students' conclusion about the evolution of pandas and bears?]	Key may focus on data evidence in another form (genetic, fossil, anatomy) or more accurate/complete data. Distractors may include irrelevant data, data that are less useful in supporting the conclusion, or data that refute/reject the conclusion.

Student Misconceptions:

*Response options can make use of Student Misconceptions (examples of scientifically incorrect assumptions) related to this performance expectation; references to misconceptions are listed below:

From www.montana.edu/kalinowski/documents/2011_Andrews_et_al_AreHumandEvolvingEvoEduOutreach.pdf:

- Students believe change happens as a result of need or desire.
- Students believe change has always occurred and always will occur.
- Students believe traits that are used are retained and those traits that are not used are lost.
- Students believe selection only occurs when organisms die.
- Students believe all organisms in a species are essentially alike.
- Students believe evolution equals speciation.

Biological Unity and Diversity: B.LS4.2*

back to “Item Specifications by Performance Expectation”

B.LS4.2. Construct an explanation based on evidence that biological diversity is influenced by (1) the potential for a species to increase in number, (2) the heritable genetic variation of individuals in a species due to mutation and sexual reproduction, (3) competition for limited resources, and (4) the proliferation of those organisms that are better able to survive and reproduce in the environment.

OAS-S Clarification Statement:

Emphasis is on using evidence to explain the influence each of the four factors has on number of organisms, behaviors, morphology, or physiology in terms of ability to survive and reproduce. Examples of evidence could include mathematical models such as simple distribution graphs and proportional reasoning.

OAS-S Assessment Boundary:

Assessment does not include genetic drift, gene flow through migration, and co-evolution.

Science & Engineering Practice:

Constructing Explanations

- Construct an explanation based on valid and reliable evidence obtained from a variety of sources (including students’ own investigations, models, theories, simulations, peer review) and the assumption that theories and laws that describe the natural world operate today as they did in the past and will continue to do so in the future.

Disciplinary Core Idea:

Natural Selection

- Natural selection occurs only if there is both (1) variation in the genetic information between organisms in a population and (2) variation in the expression of that genetic information—that is, trait variation—that leads to differences in performance among individuals.

Crosscutting Concept:

Cause and Effect

- Empirical evidence is required to differentiate between cause and correlation and make claims about specific causes and effects.

In Lay Terms:

Students should be able to construct and defend explanations using evidence to show how genetic variation leads to differences in the survival and reproduction success of individuals having different traits within populations. This phenomenon is driven by the degree of genetic variation present, the reproductive capacity of the species, competition for resources, and the favorability of particular traits for individuals.

Cluster Clarifications:

- Avoid using artificial selection examples.

Cluster Stimulus Attributes:

Typical stimulus elements:

- mathematical models, including distribution graphs/models of population density (various distribution patterns)
- numerical data as a basis for proportional reasoning
- text scenarios of natural selection examples, including factors and survival/reproduction outcomes

Possible contexts:

- research/investigations about natural selection as an explanation for biological diversity
- heritable genetic variation of individuals in a species due to mutation and sexual reproduction as an explanation for biological diversity
- research/investigations about competition as an explanation for biological diversity
- research/investigations about proliferation of the organisms that are better suited to survive and reproduce as an explanation for biological diversity

Biological Unity and Diversity: B.LS4.2*

Content and evidence to be included: text, models, tables, and graphical representations as evidence for patterns of traits within populations or differential survival due to specific traits leading to increased biological diversity

Types of student responses that need to be supported: explaining the factors that influence biological diversity (i.e., natural selection), including analysis and evaluation of results and observations

Allowable Item Types:

- MC
- TEI

**associated sample cluster included*

Model Item Descriptions for B.LS4.2:

#	Item Type	Model Stem (Items ask students to...)	Response Characteristics*
1	MC	Based on evidence, explain how/why individuals that have a competitive advantage can survive and reproduce at a higher rate. [Based on the data in the table, why does the percentage of green speckles increase in the sunfish population?]	Key may focus on numerical data on survival or population increases to support a trait that conveys a competitive advantage. Distractors may include explanations that include misconceptions or errors regarding the connection between competitive advantage and increased survival or reproduction.
2	MC	Identify evidence that supports an explanation that DNA, mutations, or amino acid sequences result in a physiological difference that affects an organism's survival. [Which data show that the mutation provided future generations of bees a survival advantage?]	Key may focus on a cause-effect relationship between the specified trait and survival. Distractors may include identification of evidence that doesn't support the survival advantage or the trait as the cause.
3	MC	Use evidence to construct an explanation that differential survival and reproduction can lead to natural selection over time. [Which statement best explains why the small key deer body size resulted from natural selection?]	Key may focus on examples of subspecies, speciation, or redistribution of traits in a population. Distractors may include explanations without data support or explanations that include misconceptions about how differential survival enables natural selection.
4	MC	Determine which explanation for why/how genetic variation is necessary for biological diversity to increase is supported by the data. [Based on the cheetah population and genetic data, which statement about future diversity in the African cheetah population is best supported?]	Key may focus on data examples of a genetic diversity decrease in isolated or diminished populations, or on the inability of populations with limited diversity to increase in diversity despite population growth. Distractors may include explanations that are not supported by the data or that contain misconceptions about variation and diversity.
5	MC	Determine whether data support or reject an explanation for how/why mutation/sexual reproduction impacts diversity. [Which data best rejects the student's explanation about how the plant's method of reproduction influences the variety of flower types?]	Key may focus on data that support or refute the explanation based on the variation caused by mutation/sexual reproduction. Distractors may include inaccurate support/refutation statements or statements that neither support nor refute the explanation.
6	MC	Identify the data support for an explanation of diversity due to competition for resources. [Which data support the explanation about how competition affects the diversity of the ant population?]	Key may focus on data that show a relationship between competition and diversity. Distractors may include identification of extraneous data or data that do not adequately support the explanation.

#	Item Type	Model Stem (Items ask students to...)	Response Characteristics*
7	MC	Identify appropriate explanations of cause-effect relationships between genetic variation, opportunity and ability of a species to proliferate, and diversity. [Which statement best explains the relationship between the reproductive rate of African elephants and the genetic diversity shown in the data?]	Key may focus on relationships linking the genetic or environmental cause to the diversity effect. Distractors may include statements that do not sufficiently explain, statements that explain alternate phenomena, or statements lacking critical conceptual connections.
8	MC	Use evidence to explain which diversity mechanism(s) (reproductive capacity, degree of variation, competition, or favorability of traits) applies to the situation cited in an example. [Based on the data, which effect most contributed to the increased variation in guppy body coloration in the experiment?]	Key may focus on the mechanism(s) that most significantly impacted a change in diversity (greater or lesser). Distractors may include explanations not supported by the data or relating to a mechanism without a significant effect.
9	MC	Identify evidence that supports a student explanation for the favorability of a trait leading to an increase in diversity. [What evidence supports the students' explanation for how crows that use traffic nut-cracking techniques became more common in urban areas?]	Key may focus on data evidence of increasing diversity due to favorability of a trait. Distractors may include data that do not provide sufficient/valid evidence or data related to other diversity factors.
10	MC	Provide additional clarification to improve an explanation for a change in diversity due to genetic or environmental factors. [Which additional statement/clarification will best improve the explanation for why thicker fur was an advantage for the foxes living in extreme climates?]	Key may focus on statements linking the factor that influenced the change in diversity to the increase or decrease in diversity, according to the data evidence. Distractors may include information/data/statements that do not provide an improved explanation.
11	TEI	Construct a model of biodiversity by placing the explanations for significant influences appropriately in a flow chart model. [Using the provided statements, create a flow chart model to explain which factors influence biodiversity of this species.]	Drag-drop interaction. Statements would relate to the factors listed in the performance expectation (e.g., sexual reproduction yields genetic variation, competition allows the most fit individuals to survive, faster reproduction rates encourage variation). Correct responses show a complete, accurate model as explanation. Partial credit would be awarded for a subset of correct responses.

#	Item Type	Model Stem (Items ask students to...)	Response Characteristics*
12	TEI	<p>Construct an explanation for genetic variation contributing to diversity by providing a description, evidence, and reasoning based on experimental data.</p> <p>[Using the provided statements, construct an explanation for the process by which diversity in wild sunflowers may change.]</p>	<p>Drag-drop interaction.</p> <p>Statement options would include descriptions, evidence, and reasoning to be selected and placed in cells of a table or flow chart.</p> <p>Item can ask for multiple scenarios (e.g., two different organisms, two different types of change, etc.)</p> <p>Correct responses show an accurate explanation with all required components.</p> <p>Partial credit would be awarded for a subset of correct responses.</p>

Student Misconceptions:

*Response options can make use of Student Misconceptions (examples of scientifically incorrect assumptions) related to this performance expectation; references to misconceptions are listed below:

From www.montana.edu/kalinowski/documents/2011_Andrews_et_al_AreHumandEvolving_EvoEduOutreach.pdf:

- Students believe change happens as a result of need or desire.
- Students believe change has always occurred and always will occur.
- Students believe traits that are used are retained and those traits that are not used are lost.
- Students believe selection only occurs when organisms die.
- Students believe all organisms in a species are essentially alike.
- Students believe evolution equals speciation.

Sample Cluster for B.LS4.2:

Use the information to answer the following questions.

A student learns in class that cliff swallows are birds that live in the northern Great Plains. Cold weather events that last for several days decrease the availability of insects that cliff swallows primarily eat. The student knows that like other animals, cliff swallows store fat in their bodies that can be broken down to provide energy. Fat also helps animals retain heat in their bodies. The student wonders how cold weather events affect cliff swallow populations. They find a graph that shows how the average body size of a cliff swallow population changed after the birds were exposed to average temperatures and below-average temperatures. Body size is an inherited trait. The graph is shown.

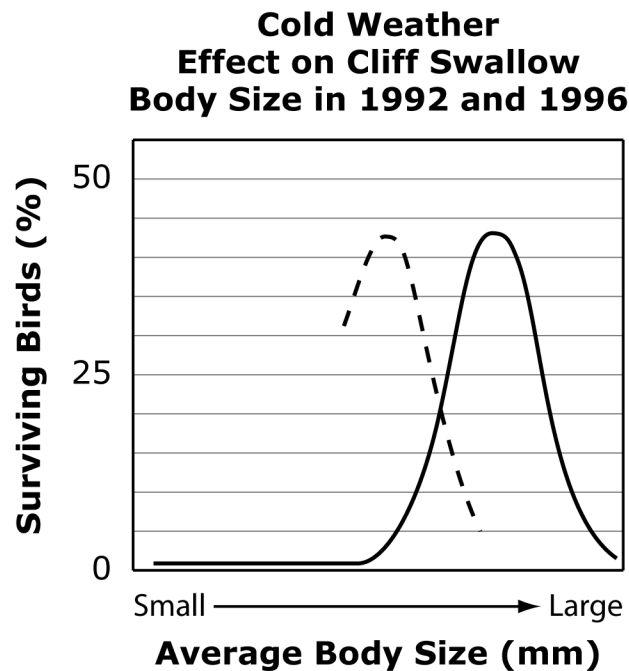

Key

- | |
|--------------------------------|
| - - - = Average temperatures |
| — = Below-average temperatures |

The student learns that there was a high survival rate in the cliff swallow population in 1992, suggesting that the average body size in 1992 was comparable to what it was before there were average temperatures.

They also find a graph that shows how below-average temperatures affected the average body size of the offspring of surviving cliff swallows. The graph is shown.

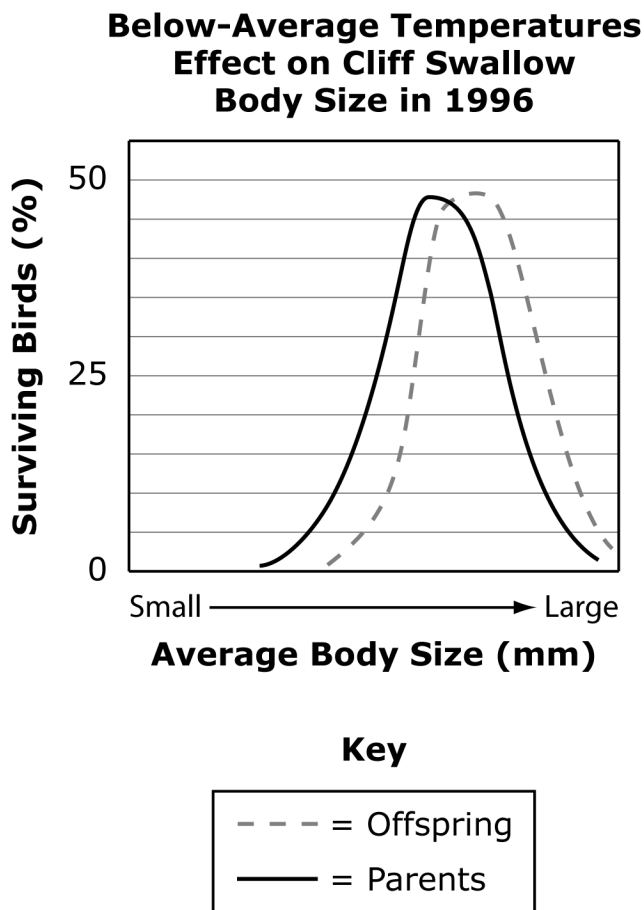

(Items on the following pages)

- 1** Which statement explains what would **most likely** occur to the cliff swallow population after 1996 if below-average temperatures became more frequent?
- A** Cliff swallows with small average body sizes would become smaller because fat stores in individual swallows would decrease.
 - B** More cliff swallows would have larger average body sizes because there would be more birds inheriting larger bodies in each generation.
 - C** More cliff swallows would have smaller average body sizes because birds with smaller bodies would only have offspring with smaller bodies.
 - D** Cliff swallows with large average body sizes would become a new species because there would be more birds with large bodies in each generation.

Standard: Construct an explanation based on evidence that biological diversity is influenced by (1) the potential for a species to increase in number, (2) the heritable genetic variation of individuals in a species due to mutation and sexual reproduction, (3) competition for limited resources, and (4) the proliferation of those organisms that are better able to survive and reproduce in the environment.

Cognitive Complexity:

SEP: Med

DCI: High

CCC: Med

Overall Cognitive Complexity: Low Support

Distractor Rationale:

- A. The data suggests that swallows with smaller average body sizes would become less frequent in the population since having less fat stores would increase the likelihood of birds with smaller bodies dying when temperatures are below-average.
- B. Correct. An increase in the frequency of below-average temperatures would likely increase the proliferation of birds with larger body sizes that are more likely to survive and reproduce.**
- C. The data suggests that birds with larger body sizes would become more frequent in the population if below-average temperatures became more common, since birds with larger body sizes that survive are likely to also reproduce and pass down that body size trait.
- D. Students may think that evolution and speciation are the same, but a proliferation of birds with larger body sizes occurs because of differential survival and reproduction, not speciation

- 2** Based on evidence from the graphs, which statement explains the differences in body size distribution in the cliff swallow population after below-average temperatures?
- A** Below-average temperatures result in fewer birds with smaller bodies reproducing than birds with larger bodies.
 - B** Below-average temperatures result in birds with smaller bodies choosing to develop larger bodies to survive.
 - C** Below-average temperatures result in birds with larger bodies becoming a different species than birds with smaller bodies.
 - D** Below-average temperatures result in more birds with larger bodies in the population because the large body size trait is used and retained.

Standard: Construct an explanation based on evidence that biological diversity is influenced by (1) the potential for a species to increase in number, (2) the heritable genetic variation of individuals in a species due to mutation and sexual reproduction, (3) competition for limited resources, and (4) the proliferation of those organisms that are better able to survive and reproduce in the environment.

Cognitive Complexity:

SEP: Low

DCI: Med

CCC: Med

Overall Cognitive Complexity: Moderate Support

Distractor Rationale:

- A. Correct.** Fewer offspring with smaller body sizes after below-average temperatures suggests that fewer parent birds with smaller body sizes were reproducing and passing down the small body size trait.
- B.** Students may think that change happens as a result of choice and that birds can intentionally choose to have larger bodies.
- C.** Students may think that evolution is the same as speciation.
- D.** Students may think that traits that are not used are lost.

- 3** Based on evidence from the graphs, which statement **best** explains why the cliff swallow body size resulted from natural selection?
- A** Cliff swallows with the largest body sizes can survive cold weather.
 - B** Cliff swallow offspring inherit body size traits that differ from their parents.
 - C** There is variation in the body size trait that leads to differences in cliff swallow survival.
 - D** Variations in body size for the largest birds are uncommon in the cliff swallow population.

Standard: Construct an explanation based on evidence that biological diversity is influenced by (1) the potential for a species to increase in number, (2) the heritable genetic variation of individuals in a species due to mutation and sexual reproduction, (3) competition for limited resources, and (4) the proliferation of those organisms that are better able to survive and reproduce in the environment.

Cognitive Complexity:

SEP: Low

DCI: Med

CCC: Med

Overall Cognitive Complexity: Moderate Support

Distractor Rationale:

- A. While the graphs indicate that this is true, this statement does not indicate how differences in body size arose due to differential survival and reproduction.
- B. While the graphs indicate that this can occur, this statement does not indicate how differences in body size arose due to differential survival and reproduction.
- C. Correct. This statement is supported by the graphs and explains why body size resulted from natural selection, by indicating that body size is a trait variant that was acted upon by natural selection because cliff swallows with a particular variant had a greater chance of surviving to reproduce than cliff swallows with other trait variants.**
- D. This statement is not evidenced from the graphs and does not refer to differential survival as part of how body size resulted from natural selection.

Biological Unity and Diversity: B.LS4.3*

back to “Item Specifications by Performance Expectation”

B.LS4.3. Apply concepts of statistics and probability to support explanations that organisms with an advantageous heritable trait tend to increase in proportion to organisms lacking this trait.

OAS-S Clarification Statement:

Emphasis is on analyzing shifts in numerical distribution of traits and using these shifts as evidence to support explanations for adaptations.

OAS-S Assessment Boundary:

Emphasis is on students’ abilities to analyze shifts in numerical distribution of traits as evidence to support explanations. Analysis is limited to basic statistical and graphical analysis, not allele or gene frequency calculations.

Science & Engineering Practice:

Analyzing and Interpreting Data

- Apply concepts of statistics and probability (including determining function fits to data, slope, intercept, and correlation coefficient for linear fits) to scientific and engineering questions and problems, using digital tools when feasible.

Disciplinary Core Idea:

Natural Selection

- Natural selection occurs only if there is both (1) variation in the genetic information between organisms in a population and (2) variation in the expression of that genetic information—that is, trait variation—that leads to differences in performance among individuals.
- The traits that positively affect survival are more likely to be reproduced, and thus are more common in the population.

Adaptation

- Natural selection leads to adaptation, that is, to a population dominated by organisms that are anatomically, behaviorally, and physiologically well suited to survive and reproduce in a specific environment. That is, the differential survival and reproduction of organisms in a population that have an advantageous heritable trait leads to an increase in the proportion of individuals in future generations that have the trait and to a decrease in the proportion of individuals that do not.
- Adaptation also means that the distribution of traits in a population can change when conditions change.

Crosscutting Concept:

Patterns

- Different patterns may be observed at each of the scales at which a system is studied and can provide evidence for causality in explanations and phenomena.

**associated sample cluster included*

Biological Unity and Diversity: B.LS4.3*

In Lay Terms:

Students should be able to use analyze data to show/verify increased frequency of traits that favor survival in populations. Because these traits favor the survival of individuals, these surviving individuals are more likely to reproduce than individuals without the traits, leading to more offspring that have these traits in the next generation. Successive accumulation of such traits in populations can lead to adaptation of a species in response to changes in environmental conditions.

Cluster Clarifications: (none)

Cluster Stimulus Attributes:

Typical stimulus elements:

- summaries of research evidence
- tables, graphs, and models

Possible contexts:

- genetic/fossil/comparative anatomy statistical studies examining genetic drift, geographic isolation, adaptive radiation, natural selection, adaptation, or extinction events (though the terms for these mechanisms should be avoided or de-emphasized)
- comparisons of proportions within species data to analyze shifts in numerical distribution of traits within a population (without calculating Hardy-Weinburg)
- investigations comparing/contrasting events that cause changes of genetic frequencies

Content and evidence to be included: quantitative and supporting data/information showing proportional changes and shifts in traits within populations

Types of student responses that need to be supported: analyzing data to describe trends or probabilities; describing and explaining data as evidence to support explanations and predictions

Allowable Item Types:

- MC
- TEI

Model Item Descriptions for B.LS4.3:

#	Item Type	Model Stem (Items ask students to...)	Response Characteristics*
1	MC	Analyze information from data tables and graphs to state results of shifts in the numerical distribution of favorable/unfavorable traits within a population. [Which result of periodic drought on the mosquito traits is supported by the data?]	Key may focus on an increase in frequency for a favorable trait or a decrease in frequency for an unfavorable trait. The function of traits should be clearly described in text accompanying the numerical data. Distractors may include data for traits that are not based on favorability or that are unrelated to the population/factors.
2	MC	Use statistical data evidence to support explanations about the influence of traits that directly influence survival on the frequency of that trait in a population or gene pool.	Key may focus on a trend in the data showing a prevalence of the trait in a later generation. Distractors may include evidence that does not support the explanation or misconceptions about the cause of the data trend.
3	MC	Analyze trends in population data to describe/explain how adaptation occurs when continual selection favors survival or reproduction of individuals with a specific trait.	Key may focus on an adaptation in a stable population due to favorable selection. Distractors may include analyses of trends that are not related to the cause-effect scenario or data that do not show trends.
4	MC	Make conclusions about trends involving trait frequency in a population or species as shown by the data/graphs from an investigation. [Which conclusion is best supported by the graphs of bass body length versus flow rate of rivers?] [What trend is shown in the frequency of the late-emerging nymphs in the dragonfly populations among the five study sites?]	Key may focus on increases or decreases in abundance or frequency of traits due to an observed pattern in an influencing environmental factor. Distractors may include conclusions that are unrelated to or not supported by the variable relationships in the data.
5	MC	Use empirical data to make a conclusion about cause-effect relationships affecting adaptation in a species. [Which environmental factor most likely caused the polar bear adaptations?] [Which statement best describes the relationship between habitat type and color variation in the screech owl population?]	Key may focus on descriptions of the cause and/or effect illustrated between independent and dependent variables. Distractors may include environmental factors that do not influence adaptation or factors that are not distinctly environmental.
6	MC	Use empirical data to make a conclusion/claim about the degree of change in variation or distribution of traits. [Which conclusion about the frequency of deer with small antlers is supported by the data?]	Key should involve some level of data inference or analysis to distinguish it from model stem #1. Distractors may include conclusions/statements unsupported by the evidence.

#	Item Type	Model Stem (Items ask students to...)	Response Characteristics*
7	MC	Compare or contrast data for a stabilized trait to data for a trait being selected in a population to describe the effect of the selection pressure on the population. [Based on the data, which of the following best describes the influence of drought on meadowlark nesting behavior?]	Key may focus on identifying the causative factor and describing the effect on the subject population in terms of which trait is affected and how the population will be affected. Distractors may include descriptions of effects that do not change expression of the trait or of effects changing the expression of the trait in other ways.
8	MC	Use population/trait distribution data tables, models, or graphs to show that organisms with advantageous traits appear more frequently over time following an environmental change. [Which graph best represents the traits that appeared over time following the change to the environment?]	Key should focus on representing the trait shift, based on data/evidence and DCI knowledge of selection for advantageous traits. Distractors may include representations based on misconception or other representations not supported by the data or valid concept reasoning.
9	MC	Relate the validity or accuracy of statistical data to the reliability of an explanation/conclusion about which traits are being favored and/or why they are favored in a population. [How is the scientist's claim about mortality in the frog population affected by the lack of data from 1984 to 2002?]	Key may focus on data measurement or reporting that demonstrates either accuracy/validity or the lack thereof in relation to the claim/conclusion being made. Distractors may include characteristics of the data that do not affect reliability or that affect the reliability of a different claim.
10	MC	Explain the cause or basis of absence/rarity of a trait in a population based on the data. [Based on the data, why is the dark color phase of the goose so rare?]	Key may focus on unfavorable traits that are selected against/not favored, based on the data. Distractors may include genetic or environmental factors, or combinations thereof, that would not support the evident pattern in the data.
11	MC	Represent or reorganize empirical data in a different form to show trend, frequency, distribution, etc. based on the variables of the investigation. [Which graph illustrates the frequency distribution pattern of the trait shown in the data table?]	Key may focus on converting the table data to graphs or map data to tables/charts/graphs to illustrate selection trends of traits. Distractors may include trends, frequencies, or distribution patterns of other data, or may show incorrect patterns or trends based on misconceptions.
12	TEI	Represent or reorganize empirical data in a different form to show trend, frequency, distribution, etc. based on the variables of the investigation. [Show the correct frequency distribution graphs for the trait and the explanation for each pattern in the correct places on the data chart for both species.]	Drag-drop interaction. Match interaction might alternately be used in some cases. Correct responses show selection/identification/association of correct data representations or transformations. Partial credit would be awarded for a subset of correct responses.

#	Item Type	Model Stem (Items ask students to...)	Response Characteristics*
13	MC	<p>Calculate relevant averages, changes, percentage, ratio, etc. to analyze and apply the data from an investigation to a question or problem involving trait favorability.</p> <p>[Based on the data, which statement best describes how much the distribution of the traits in the sparrow population changed over the time of the study?]</p>	<p>Key may focus on calculating averages, percentages, or ratios to determine frequency or distribution patterns of traits in a population.</p> <p>Distractors may include ratios, percentages, comparative values based on common misconceptions, or common application errors.</p>

Student Misconceptions:

*Response options can make use of Student Misconceptions (examples of scientifically incorrect assumptions) related to this performance expectation; references to misconceptions are listed below:

From [www.montana.edu/kalinowski/documents/2011 Andrews et al AreHumandEvolving_EvoEduOutreach.pdf](http://www.montana.edu/kalinowski/documents/2011_Andrews_et_al_AreHumandEvolving_EvoEduOutreach.pdf):

- Students believe change happens as a result of need or desire.
- Students believe change has always occurred and always will occur.
- Students believe traits that are used are retained and those traits that are not used are lost.
- Students believe selection only occurs when organisms die.
- Students believe all organisms in a species are essentially alike.
- Students believe evolution equals speciation.

Sample Cluster for B.LS4.3

Use the information to answer the following questions.

Daphne Island is a part of the Galapagos, a group of islands located in the Pacific Ocean near the western coast of South America. A ground finch (small birds that range in color, appearance, and beak size) live on the island. It has been observed that due to genetic variation, the Galapagos finches show variation in beak size. Some ground finches have a small beak and eat mostly soft seeds, whereas other ground finches that have larger beaks can also feed on hard seeds and nuts.



Smaller
beak



Larger
beak

In 1976, a group of scientists conducted a study of 751 ground finches to show the range of beak sizes for the ground finches that inhabited Daphne Island. The first graph shows the results of the 1976 study.

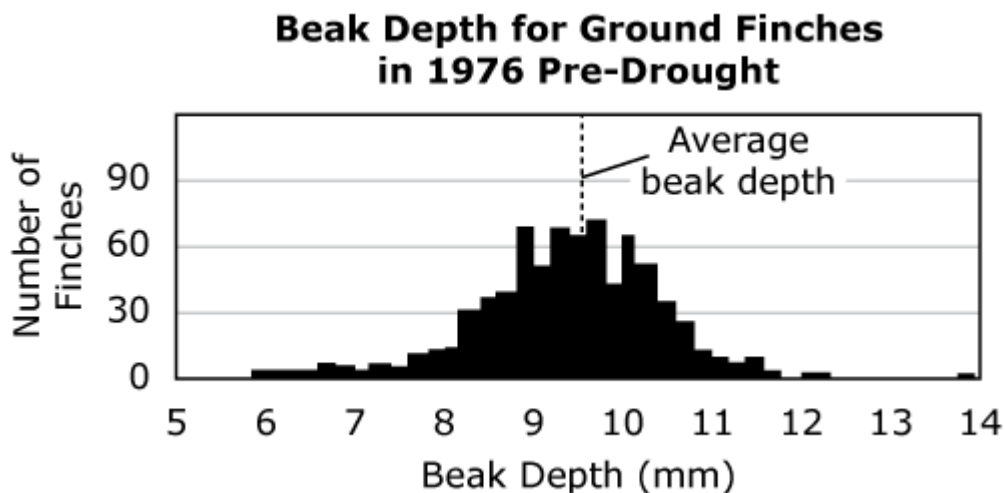

Beak Depth for Ground Finches in 1978 Post-Drought

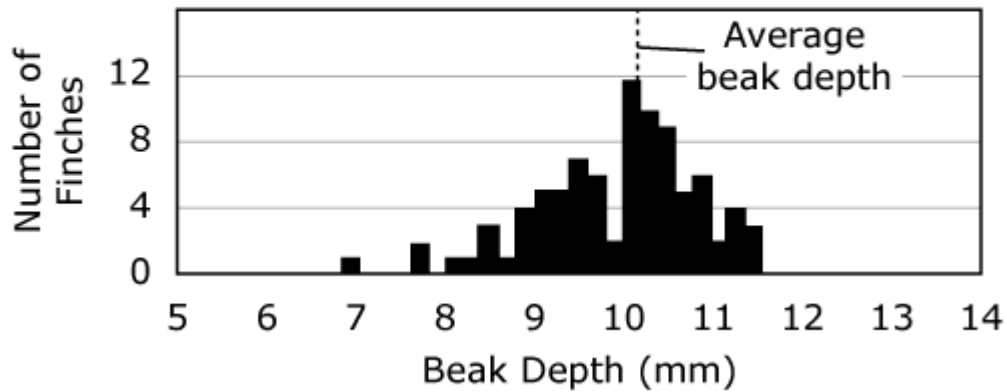

In 1977, the island experienced a severe drought that impacted the amount and type of seeds available. The drought on the island led to a food shortage that caused several hundred finches to die. In 1978 the same scientists conducted a study similar to the one in the 1976, but data were only collected for 90 of the surviving finches. The results for the 1978 study are shown in the second graph.

(Items on the following pages)

1 What do the data in the graphs show?

- A** After the drought, birds with smaller beaks had less access to food.
- B** The drought did not affect the survivability of the finch population.
- C** After the drought, birds with larger beaks had less access to food.
- D** The drought did not affect the size of the beaks in the finch population.

Standard: Apply concepts of statistics and probability to support explanations that organisms with an advantageous heritable trait tend to increase in proportion to organisms lacking this trait.

Cognitive Complexity:

SEP: Low

DCI: Medium

CCC: Medium

Overall Cognitive Complexity: Moderate Support

Distractor Rationale:

- A. Correct.** The data in the 2 graphs show a shift in beak depth, before and after the drought.
- B.** The data in the 2 graphs show a shift in beak depth, before and after the drought.
- C.** The graph does not show the correlation between bird size and beak depth.
- D.** The graph does not show the correlation between species and beak depth.

2 If the drought continues on Daphne Island, which statement describes how the offspring's beak sizes will most likely change over time?

- A** The offspring will grow into adult birds and change their beak sizes.
- B** Most of the offspring with the smallest or largest beaks will not survive over time.
- C** The offspring will grow into adult birds with smaller beaks, on average, than their parents.
- D** Offspring with medium-sized beaks will not survive, but those that adapt to the largest beak size will increase in number.

Standard: Apply concepts of statistics and probability to support explanations that organisms with an advantageous heritable trait tend to increase in proportion to organisms lacking this trait.

Cognitive Complexity:

SEP: Medium

DCI: Medium

CCC: Medium

Overall Cognitive Complexity: Moderate Support

Distractor Rationale:

- A. Individuals themselves cannot evolve.
- B. Correct. When the previous generation of finches encountered drought conditions, most of the finches with very shallow and very deep beaks dies. There is no reason to assume a similar pattern won't happen with the offspring.**
- C. There is no evidence to support this prediction. In drought conditions, the finches with shallower beaks are the least likely to survive.
- D. When the previous generation of finches encountered drought conditions, mainly finches with moderately deep beaks survived.

3 Before the drought, the finch population had a large variation in beak size.

Which statement best explains the variation in beak size?

- A** The environment was not able to support finches with medium sized beaks.
- B** Finches with small beaks migrated to other islands to survive and reproduce.
- C** Finches with small beaks were able to outcompete other finches and produce more offspring.
- D** The environment had sufficient resources so that finches with different beak sizes could survive and reproduce.

Standard: Apply concepts of statistics and probability to support explanations that organisms with an advantageous heritable trait tend to increase in proportion to organisms lacking this trait.

Cognitive Complexity:

SEP: Medium

DCI: Medium

CCC: Medium

Overall Cognitive Complexity: Moderate Support

Distractor Rationale:

- A. The data in the 1976 graph show that the environment was able to support finches with a wide range of beak sizes.
- B. There is no data or evidence to support the claim that finches with smaller beak sizes migrated to other islands.
- C. There is no data or evidence to support the claim that finches with small beaks outcompeted other finches.
- D. Correct. The data in the 1976 graph support the claim that the environment supported finches with different beak sizes.**

Biological Unity and Diversity: B.LS4.4

back to “Item Specifications by Performance Expectation”

B.LS4.4. Construct an explanation based on evidence for how natural selection leads to adaptation of populations.

OAS-S Clarification Statement:

Emphasis is on using data to provide evidence for how specific biotic and abiotic differences in ecosystems (such as ranges of seasonal temperature, long-term climate change, acidity, light, geographic barriers, or adaptation of other organisms) contribute to a change in gene frequency over time, leading to adaptation of populations.

OAS-S Assessment Boundary:

N/A

Science & Engineering Practice:

Constructing Explanations

- Construct an explanation based on valid and reliable evidence obtained from a variety of sources (including students’ own investigations, models, theories, simulations, peer review) and the assumption that theories and laws that describe the natural world operate today as they did in the past and will continue to do so in the future.

Disciplinary Core Idea:

Adaptation

- Natural selection leads to adaptation; that is, to a population dominated by organisms that are anatomically, behaviorally, and physiologically well suited to survive and reproduce in a specific environment.
- That is, the differential survival and reproduction of organisms in a population that have an advantageous heritable trait leads to an increase in the proportion of individuals in future generations that have the trait and to a decrease in the proportion of individuals that do not.
- Changes in the physical environment, whether naturally occurring or human induced, have thus contributed to the expansion of some species, the emergence of new distinct species as populations diverge under different conditions, and the decline—and sometimes the extinction—of some species.

Crosscutting Concept:

Cause and Effect

- Empirical evidence is required to differentiate between cause and correlation and make claims about specific causes and effects.

In Lay Terms:

Students should be able to construct and defend explanations using evidence for how the process of natural selection acts on populations to shape the adaptation of species. Selection pressure in the form of environmental limits and conditions determines the distribution and prevalence of genetic traits within a population. This can lead to the redistribution and change in abundance of species, emergence of new species, or the extinction of species.

Cluster Clarifications: (none)

Biological Unity and Diversity: B.LS4.4

Cluster Stimulus Attributes:

Typical stimulus elements:

- text scenarios
- data tables and graphs of specific biotic and abiotic factors over time
- information (text or graphical) about the distribution of traits or subgroups with similar traits

Possible contexts:

- examples of the roles of various biotic and abiotic factors in natural selection
- effects of natural selection on redistribution of traits within populations or redistribution of populations within a global/continental/regional range
- numeric data showing shifts in gene frequencies associated with specific selection pressures

Content and evidence to be included: text, models, tables, and graphical representations as evidence of abiotic and biotic factors and their effects on population/trait distribution shifts

Types of student responses that need to be supported: analyzing data to support and form explanations of natural selection

Allowable Item Types:

- MC
- TEI

Model Item Descriptions for B.LS4.4:

#	Item Type	Model Stem (Items ask students to...)	Response Characteristics*
1	MC	Identify the evidence that supports the explanation of a shift in genetic frequency/trait for a population. [Which data from the table support the students' explanation for the distribution of the gray color phase in the owl population?]	Key may focus on data that illustrate the causative link between a selection pressure and its effect on a variation in a population. Distractors may include data that do not support the explanation or only support it partially.
2	MC	Explain why a given result (adaptation) under a particular biotic or abiotic change would be expected, based on evidence and content knowledge. [Why would scientists expect the snail population to adapt by producing thicker shells over time in this environment?]	Distractors may include misconceptions or invalid reasoning.
3	MC	Based on evidence, construct an explanation for why the physical environment contributes to the expansion of some species and decline of others. [Based on the climatic data after the last ice age, why did the woolly mammoth become extinct while the coyote became more widespread in North America?]	Key may focus on a specific expansion/decline or may contrast a decline in one species with an expansion of another due to the same causative factor. Distractors may include explanations unsupported by evidence or based on misconceptions about species.
4	MC	Explain why proliferation or survival of a species subject to a particular biotic or abiotic change in the environment would be expected, based on evidence and content knowledge. [Based on the data, why is the harvest mouse population expected to increase over time?]	Key may focus on data links between a causative factor and a direct change in population size, reproductive efficiency, or survival rate. Distractors may include misconceptions or explanations not supported by the data or underlying concept.
5	MC	Based on evidence, explain how/why a population subject to selective pressure will result in a new trait or population distribution. [Based on the data in the table, why will the rise in average temperatures likely cause a change in the range of caribou in North America?]	Key may focus on data for a specific pressure as a cause of a new trait frequency, trait or population distribution pattern, or change in total population. Distractors may include explanations that include misconceptions or errors regarding the connection between pressure and the frequency of the trait or change in population.
6	MC	Identify evidence that supports an explanation that natural selection for a favorable trait may lead to adaptation. [Which data show that natural selection has caused all moose to be better adapted to living in snowy environments?]	Key may focus on data showing a cause-effect relationship between the selection pressure and adaptation of a species. Distractors may include identification of evidence that does not support the selection pressure or the resulting adaptation.
7	MC	Use evidence to explain why natural selection can lead to new subspecies or species. [Which statement best explains why the mouse subspecies likely resulted from natural selection?]	Key may focus on explaining the mechanism for natural selection as the cause of speciation (or subspeciation). Distractors may include explanations without data support or explanations that include misconceptions about the mechanism of natural selection or speciation.

#	Item Type	Model Stem (Items ask students to...)	Response Characteristics*
8	MC	Determine which explanation for why/how natural selection drives the frequency of a trait within a gene pool or population is best supported by the data. [Based on the climate and bloom date data, which statement about the bloom date trait in willow trees is best supported?]	Key may focus on data examples of trait frequency redistribution within a geographic range or population. Distractors may include explanations that are not supported by the data or that contain misconceptions about the natural selection mechanism, gene frequency, or the advantage/disadvantage conferred by the specified trait.
9	MC	Determine whether data do or do not support an explanation for how/why natural selection impacts the range of a species. [Which data best support the student's explanation for why the range of red juniper has increased in Oklahoma since 1930?]	Key may focus on data that support or refute the explanation based on changes in range distribution patterns from maps. Distractors may include inaccurate support/refutation statements or statements that neither support nor refute the explanation.
10	MC	Identify the data support for an explanation of diversity due to competition for resources. [Which data support the explanation about how competition affects the diversity of the ant populations?]	Key may focus on data that show a relationship between competition and diversity. Distractors may include identification of extraneous data or data that do not adequately support the explanation.
11	MC	Identify appropriate explanations of the cause-effect relationship between a change in selective factors and a species' extinction/extirpation or successful emigration/reintroduction. [Which statement best explains the relationship between the habitat data and the extirpation of elk in Oklahoma?]	Key may focus on data showing relationships between a selective factor and the resulting impact on the species. Distractors may include statements that do not sufficiently explain how/why the selective factor(s) are relevant, statements that explain alternate results, or statements lacking a connection between the selective factor(s) and the result.
12	MC	Provide additional clarification to improve an explanation for a change in diversity due to genetic or environmental factors. [Which additional statement/clarification will best improve the explanation for why thicker fur was an advantage for the foxes living in extreme climates?]	Key may focus on statements linking the factor that influenced the change in diversity to the increase or decrease in diversity based on the data evidence. Distractors may include information/data/statements that do not provide an improved explanation.
13	TE	Construct a model as an explanation for selection pressure contributing to adaptation/trait frequency distribution/speciation by providing an explanation, evidence, and reasoning based on experimental data. [Using the provided statements, construct an explanation for the process by which the given selection pressure will change the trait distribution in the sunflower population.]	Drag-drop interaction. Statement options would include descriptions, evidence, and reasoning to be selected and placed in cells of a table or flow chart. Item can ask students to address multiple selection pressures. Correct responses show an accurate explanation with all required components. Partial credit would be awarded for a subset of correct responses.

Student Misconceptions:

*Response options can make use of Student Misconceptions (examples of scientifically incorrect assumptions) related to this performance expectation; references to misconceptions are listed below:

- Students misunderstand the meaning of the terms “adapt” and “fitness.”
- Students do not see the link between genetic variation and adaptation.
- Students do not understand the amount or cause of genetic variation among organisms.

From www.tandfonline.com/doi/abs/10.1080/00958964.1994.9941962#.VPpv-uEpvm4:

- Adaptations occur due to individual needs.
- In all selection fitness is a function of the bigger and stronger organisms.
- All members of a species are very similar, and there is little variation within species or populations.

Biological Unity and Diversity: B.LS4.5

back to “Item Specifications by Performance Expectation”

B.LS4.5. Evaluate the evidence supporting claims that changes in environmental conditions may result in (1) increases in the number of individuals of some species, (2) the emergence of new species over time, and (3) the extinction of other species.

OAS-S Clarification Statement:

Emphasis is on determining cause and effect relationships for how changes to the environment such as deforestation, fishing, application of fertilizers, drought, flood, and the rate of change of the environment affect distribution or disappearance of traits in species.

OAS-S Assessment Boundary:

N/A

Science & Engineering Practice:

Engaging in Argument from Evidence

- Evaluate the evidence behind currently accepted explanations or solutions to determine the merits of arguments.

Disciplinary Core Idea:

Adaptation

- Changes in the physical environment, whether naturally occurring or human induced, have thus contributed to the expansion of some species, the emergence of new distinct species as populations diverge under different conditions, and the decline—and sometimes the extinction—of some species.
- Species become extinct because they can no longer survive and reproduce in their altered environment. If members cannot adjust to change that is too fast or drastic, the opportunity for the species’ adaptation over time is lost.

Crosscutting Concept:

Cause and Effect

- Empirical evidence is required to differentiate between cause and correlation and make claims about specific causes and effects.

In Lay Terms:

Students should be able to identify explanations and claims about the ways environmental changes affect species and, more so, to evaluate the strength of the evidence and reasoning for those explanations and claims. Species may be affected in terms of traits, survival, distribution, speciation, and extinction based on the ability or inability to adapt.

Cluster Clarifications:

- Focus is on examining explanations or claims about how environmental conditions require adaptation and affect survival and, subsequently, how this then causes species to expand, diverge (speciation), decline, or go extinct.
- Environmental changes can be human-induced or natural; examples include human development/habitat destruction, invasive species, deforestation, fishing, application of fertilizers, drought, flood, and fire.
- Students can be asked to summarize/identify the explanation or claim (of cause and effect) in some items, but most items should focus on evaluating the sufficiency and quality of evidence for the explanation or claim.
- The CCC—cause and effect—**must** be included and emphasized in the items (e.g., vocabulary of “causes,” “affects,” “influences,” “impacts,” “results in,” “leads to,” “relationship between”).

Biological Unity and Diversity: B.LS4.5

Cluster Stimulus Attributes:

Typical stimulus elements:

- text scenarios, graphs, and tables
- stated explanations or claims

Possible contexts:

- graphical representations and tables of population change (increase or decrease) as a result of changes in the environment
- adaptation examples with graphical representations of shifts in trait distributions in populations due to selection pressure/environmental change
- data from simulations of populations of organisms as they are affected by changes in the environment
- research/studies of historical context of organisms affected by changes in the environment (biodiversity changes, population size changes, speciation, extinction)

Content and evidence to be included: graphs, tables, and textual descriptions related to environment, trait, and/or population changes; complete or partial explanations or claims

Types of student responses that need to be supported: identifying explanations or claims; evaluating the evidence and reasoning for given explanations and claims

Allowable Item Types:

- MC
- TEI

Model Item Descriptions for B.LS4.5:

#	Item Type	Model Stem (Items ask students to...)	Response Characteristics*
1	MC	<p>Identify the explanation or claim that is expressed or should be inferred about how environmental changes affect species traits and adaptation.</p> <p>[Based on the data, which statement summarizes the cause-effect relationship between the size of predator populations and the body size distribution in the insect population?]</p>	<p>Key must focus on cause-effect explanation or claim.</p> <p>Distractors may include misinterpretation of the presented data and evidence or misconceptions about mechanisms for adaptation.</p>
2	MC	<p>Identify the explanation or claim that is expressed or to be inferred about how environmental changes, selection pressure, and/or adaptations affect species survival, speciation, or extinction (i.e., biodiversity).</p> <p>[Which explanation of how deforestation has affected the biodiversity of the ecosystem is supported by the data?]</p>	<p>Key must focus on cause-effect explanation or claim.</p> <p>Distractors may include misinterpretation of the presented data and evidence or misconceptions about mechanisms for biodiversity and species change.</p>
3	MC	<p>Identify the specific change in environmental conditions that causes the observed changes in species' traits, survival, distribution, speciation, and extinction.</p> <p>[Which change in environmental conditions most likely caused the declines in the monarch butterfly populations?]</p>	<p>Distractors may include irrelevant factors and conditions, particularly those based on misconceptions or confusion of causation versus correlation.</p>
4	MC	<p>Compare multiple explanations or claims about the influence of environmental changes on species (traits, distribution, survival or population size, speciation, extinction) to evaluate their relative accuracy, evidence, and reasoning.</p> <p>[Which of the explanations for the cause of the animals' extinction is better supported by the data and why?]</p>	<p>When justifications are required, key may focus on merit due to most relevant evidence, sufficient amounts of evidence, and logical reasoning.</p> <p>Distractors may include identifications and justifications that are incorrect or inconsistent with the scenario and evidence presented.</p>
5	MC	<p>Identify evidence that supports (or rejects) the explanation or claim about the effect(s) of environmental factors/changes on species.</p> <p>[Which evidence best supports the explanation for the shark populations' decline due to habitat destruction?]</p>	<p>Distractors may include incorrect, insignificant, or irrelevant data.</p>
6	MC	<p>Identify or describe the reasoning for the explanation or claim about species changes based on the evidence.</p> <p>[Which reasoning best supports the explanation for the observed changes in seed size over time?]</p> <p>[How does the evidence support the explanation for the appearance of the new salamander species?]</p>	<p>Distractors may include invalid or unsupported reasoning, particularly based on misconceptions.</p>

#	Item Type	Model Stem (Items ask students to...)	Response Characteristics*
7	MC	Evaluate the quality of the data, evidence, and/or reasoning for the explanation or claim about the cause of the changes in traits or biodiversity (i.e., do—and/or <i>how</i> do—the data, evidence, or reasoning support the explanation or claim?). [Which statement best evaluates whether the given evidence supports the explanation for the decrease in the number of frog species in the ponds?]	Key may focus on the relevance, accuracy, and/or sufficiency of the data/evidence. Distractors may include misunderstanding of quality evidence, illogical connections, and/or misapplication of the data/evidence based on misconceptions.
8	MC	Explain whether the given explanation or claim about the cause of the changes in traits or biodiversity is supported or d rejected by the observations/data/evidence (i.e., merit of the explanation or claim). [Which statement explains whether the explanation for the cause of the changes in shell coloration over time is supported by the data?]	Distractors may include misinterpretation of data and evidence or may draw from misconceptions or unrelated cause-effect observations.
9	MC	Identify additional evidence that would support the explanation or claim about how environmental changes affect species traits and biodiversity. [Which additional evidence would support the explanation for how changes in water pH have caused the decreases in biodiversity in the lake?]	Key may focus generally on the type of evidence needed (e.g., “data about the pH range within which each fish species can survive”) or identify specific data (e.g., “the pH decreased from 7.4 in 1980, to 6.5 in 1990, to 5.2 in 2000”). Distractors may include incorrect or irrelevant data, particularly based on misconceptions.
10	MC	Differentiate between cause and correlation based on the given evidence about the changes in environment and species. [Which statement explains whether the changes in average fish body size were caused by changes in gill net size or were only correlated with changes in gill net size?]	Distractors may include incorrect classifications based on misconceptions and incorrect reasoning around causation versus correlation.
11	TEI	Distinguish evidence that supports from evidence that does not support an explanation and provide reasoning for the distinction. [Sort the evidence statements into those that support the explanation for the changes in the species and those that do not.]	Drag-drop interaction. Some items may require students to associate reasoning with their responses. Correct responses show proper sorting of evidence that does and does not support the explanation. Partial credit would be awarded for a subset of correct responses.

Student Misconceptions:

*Response options can make use of Student Misconceptions (examples of scientifically incorrect assumptions) related to this performance expectation; references to misconceptions are listed below:

- Students misunderstand the meaning of the terms “adapt” and “fitness.”
- Students do not see the link between genetic variation and adaptation.
- Students do not understand the amount or cause of genetic variation among organisms.

From www.tandfonline.com/doi/abs/10.1080/00958964.1994.9941962#.VPpv-uEpm4:

- Adaptations occur due to individual needs.
- In all selection fitness is a function of the bigger and stronger organisms.
- All members of a species are very similar, and there is little variation within species or populations.

Matter and Its Interactions: PS.PS1.1*

back to “Item Specifications by Performance Expectation”

PS.PS1.1. Use the periodic table as a model to predict the relative properties of elements based on the patterns of electrons in the outermost energy level of atoms.

OAS-S Clarification Statement:

Examples of properties that could be predicted from trends and patterns could include reactivity of metals, types of bonds formed, numbers of bonds formed, and reactions with oxygen.

OAS-S Assessment Boundary:

Assessment is limited to main group elements. Assessment does not include understanding of ionization energy and electronegativity.

Science & Engineering Practice:	Disciplinary Core Idea:	Crosscutting Concept:
Developing and Using Models <ul style="list-style-type: none">Use a model to predict the relationships between systems or between components of a system.	Structure and Properties of Matter <ul style="list-style-type: none">Each atom has a charged substructure consisting of a nucleus, which is made of protons and neutrons, surrounded by electrons.The periodic table orders elements horizontally by the number of protons in the atom’s nucleus and places those with similar chemical properties in columns. The repeating patterns of this table reflect patterns of outer electron states.	Patterns <ul style="list-style-type: none">Different patterns may be observed at each of the scales at which a system is studied and can provide evidence for causality in explanations of phenomena.

In Lay Terms:

Students should be able to make predictions about the behavior and properties of main group elements based upon their relative position in the periodic table, and the trends in their outermost energy levels of electrons.

Cluster Clarifications:

- In contrast to PS.PS1.2, this PE deals with elements in isolation.
- This PE focuses on the periodic table being used as a model. Therefore, questions concerning specific trends relating to groups and periods (atomic radius) need to be provided as data that can be referenced.
- The structure of the periodic table must be referenced in stimulus (i.e., groups and periods defined).
- Terms such as “atomic radius,” “electron affinity,” and “metalloid” should be defined. The terms electronegativity and ionization energy should not be used.
- Ions are not assessable content.
- For the purposes of this assessment and this PE, reactivity is defined as the likelihood of an element to gain or lose electrons.
- To align to CCC, items may examine a phenomenon at two different scales or the cluster may examine a phenomenon at two different scales (macroscopic and microscopic).

**associated sample cluster included*

Matter and Its Interactions: PS.PS1.1*

Cluster Stimulus Attributes:

Typical stimulus elements:

- periodic table
- data table describing properties of elements; for example, number of protons, electrons, atomic mass, size of nucleus (see OAS-S Clarification Statement)
- atomic model
- text descriptions

Possible contexts:

- specific trends seen in periodic table: atomic radii; metallic character (e.g., metal, metalloid, non-metal); atomic number; mass; numbers of protons, neutrons, electrons in atoms
- mercury in Lewis and Clark expedition
- use of helium versus hydrogen in Hindenburg (i.e., How did small scale properties produce large scale properties in that explosion?), or why are balloons filled with helium instead of hydrogen gas?
- atomic number increases, atomic mass increases (correlation)
- model of an atom in comparison to periodic table
- complete model/make prediction of structure of second based on existing model of atom and periodic table

Content and evidence to be included: information/descriptions of properties of elements; models; patterns

Types of student responses that need to be supported: interpreting the periodic table to describe trends and make predictions, explaining how evidence supports predictions, relating trends in periodic table to atomic structure, analyzing evidence to support the model

Allowable Item Types:

- MC
- TEI

Model Item Descriptions for PS.PS1.1:

#	Item Type	Model Stem (Items ask students to...)	Response Characteristics*
1	MC	Use the periodic table to identify the subatomic structure of atoms.	Distractors may include models showing incorrect placement of subatomic structures, or structure of nearby atoms.
2	MC	Explain how the data fit/support the model (i.e., are evidence for the model). [How does the data support the position of elements shown in the periodic table?]	Distractors may include explanations that incorrectly relate the data to the model.
3	MC	Analyze evidence to support the model. [Mendeleev identified gaps in his periodic table. Based on the information in the table, which unknown element (W, X, Y, Z) best fills the gap shown?]	Distractors may include evidence that is irrelevant or which can serve to reject the model. Note that the unknown elements should not be identified with atomic number, etc., so that students are using DCI knowledge and not simply noticing a trend in the data.
4	MC/ TE	Determine which element(s) behave most like another when given information from the periodic table. [Click on the elements that will behave most like lithium when reacted with oxygen.] [(Provide number of electrons in outer shell in data table.) Which of these four elements would behave similarly? (e.g., carbon, silicon)]	Hot-spot interaction. Distractors may include other elements of the periodic table.
5	MC	Use data and the periodic table to predict how the valence electrons of an atom affect its reactivity. [Based on the data table and the periodic table, how does the number of valence electrons affect the reactivity of an element?]	Distractors may include predictions made from only a portion of the relevant data. Define reactivity in stimulus.
6	MC/ TE	Describe trends in sizes of atoms as one moves down a group or across a row of the periodic table. [Drag the symbols to predict the structure of the atom based on the information in the periodic table and the atom shown.] [Drag and drop the data to complete the periodic table (using data not shown in the provided periodic table).]	Drag-drop interaction. Data to drag and drop includes: atomic radius
7	MC	Use the periodic table/data to predict the relative reactivity of an element. [Based on the information shown in the periodic table and data shown in the table, which of the elements in Group I will react most vigorously when added to water?]	Distractors may include predictions that interpolate or extrapolate data that is irrelevant or inconsistent with the pattern described. Define reactivity in stimulus.

#	Item Type	Model Stem (Items ask students to...)	Response Characteristics*
8	MC	Use the periodic table to explain that elements with similar chemical properties are placed in groups.	Distractors may include statements that do not sufficiently explain, statements that explain alternate phenomena, or statements lacking critical conceptual connections. Stem/stimulus must also contain a chart containing valence electrons.
9	MC	Describe the cause-effect relationship between patterns of reactivity of elements and the outermost electrons for their atoms. [How do the observations shown in the table relate to their atomic structure?]	Distractors may include statements that do not sufficiently explain, statements that explain alternate phenomena, or statements lacking critical conceptual connections. Define reactivity in stimulus.
10	MC	Relate the large and small scale properties of substances to their position on the periodic table.	Distractors may include statements that do not sufficiently explain, statements that explain alternate phenomena, or statements lacking critical conceptual connections.

Student Misconceptions:

*Response options can make use of Student Misconceptions (examples of scientifically incorrect assumptions) related to this performance expectation; references to misconceptions are listed in the links below:

- The periodic table provides only an element's name, symbol, atomic number, and atomic mass.
- The more subatomic particles contained in an atom, the larger the atom.
- When the total number of electrons is changed in the atom, periodic properties do not change.
- Electrons have a positive charge.

From onlinelibrary.wiley.com/doi/10.1002/tea.3660290203/full

- Students misuse atomic mass when analyzing patterns of reactivity from the periodic table.

Sample Cluster for PS.PS1.1

Use the information to answer the following questions.

In the 1930s, the first commercial airlines carried passengers across the Atlantic Ocean. But the passengers did not travel in airplanes. Instead, they traveled in airships.

The Zeppelin Construction Company, a German company, built an airship they named "LZ-129 Hindenburg." The Hindenburg was the largest object ever flown. Most of the volume of this airship was filled with the 200,000 cubic meters of gas used to lift the ship into the air.

When designing the Hindenburg, engineers considered the density of air, which is 1.229 g/L. They considered two different gases to fill the airship, hydrogen and helium. Characteristics of those gases, plus other gases produced in the 1930s, are listed in the table. Reactivity describes how likely a substance is to gain or lose electrons.

Properties of Gases Produced in the 1930s

Gas	Number of Electrons in Valence Shell	Density (g/L)	Reactivity
Hydrogen	1	0.089	Highly likely
Helium	2	0.090	Not likely
Fluorine	7	1.700	Highly likely
Neon	8	0.900	Not likely
Chlorine	7	3.200	Highly likely
Argon	8	1.784	Not likely

Due to cost concerns, the Hindenburg engineers chose inexpensive hydrogen gas to fill their airship.

The Hindenburg made thirty-seven flights across the Atlantic Ocean in 1936 and 1937.

Then, on May 6, 1937, disaster struck as the ship was landing in stormy weather. Most researchers agree that a spark ignited leaking hydrogen. Within thirty-two seconds, the entire ship was engulfed in flames, taking the lives of some on board. The photograph, taken in the first few seconds of the explosion, shows the scale of the disaster.

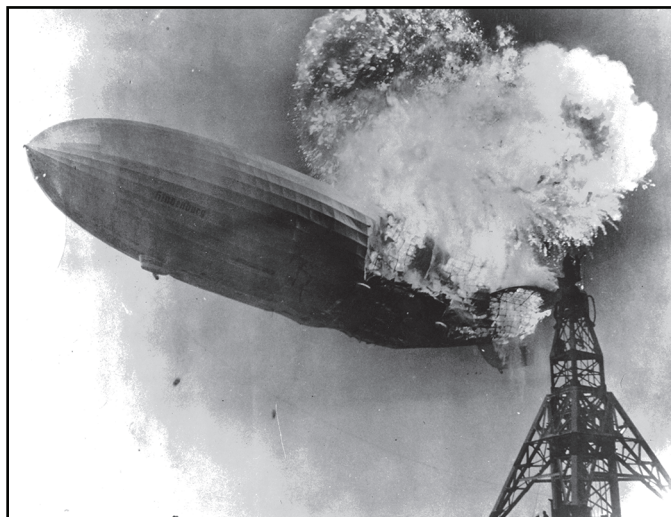

U.S. Navy

Today, airships are still used across the world. However, as a result of the Hindenburg disaster, they are no longer filled with hydrogen.

(Items on the following pages)

1 Based on the information shown in the periodic table and data table, what is the subatomic structure of helium?

A

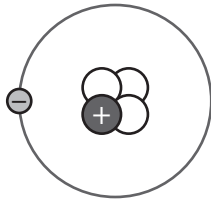

B

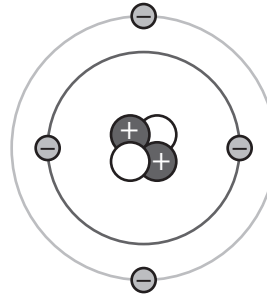

C

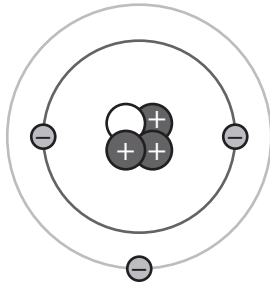

D

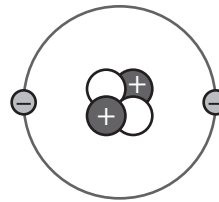

Standard: Use the periodic table as a model to predict the relative properties of elements based on the patterns of electrons in the outermost energy level of atoms.

Cognitive Complexity:

SEP: Low

DCI: Low

CCC: N/A

Overall Cognitive Complexity: Scripted

Distractor Rationale:

- A. The student may think that proton number should match valence electrons.
- B. The student may think that the first electron shell is filled and then there are two valence electrons.
- C. The student may think that this model represents two valence electrons and that there should be an equal number of protons.
- D. **Correct.** The number of valence electrons matches number of protons, and the number of nuclear particles matches atomic mass.

2 The periodic table organizes information into horizontal rows called periods and vertical columns called groups. How do the data shown in the table relate to the organization of the periodic table?

- A** Elements with similar densities are placed into the same group.
- B** Elements with similar densities are placed into the same period.
- C** Elements with similar numbers of valence electrons are placed into the same group.
- D** Elements with similar numbers of valence electrons are placed into the same period.

Standard: Use the periodic table as a model to predict the relative properties of elements based on the patterns of electrons in the outermost energy level of atoms.

Cognitive Complexity:

SEP: Low

DCI: Med

CCC: Med

Overall Cognitive Complexity: Moderate Support

Distractor Rationale:

- A. The student may have confused density with reactivity.
- B. The student may think that density increases proportionally with atomic mass.
- C. Correct. This pattern is seen for He, Ne, and Ar as well as for Cl and F.**
- D. The student may be confused about the organization of the periodic table.

3 How does the observation of reactivity described in the data table and text relate to hydrogen's location on the periodic table?

- A** Hydrogen's location shows that it has one free electron in its valence shell; this electron is given up freely during reactions.
- B** Hydrogen's location shows that it has one free electron in its valence shell; this electron reacts with other elements until it has seven other electrons to fill hydrogen's valence shell.
- C** Hydrogen's location shows that it has more protons than neutrons in its nucleus; hydrogen reacts with other elements until the number of protons is balanced by additional electrons.
- D** Hydrogen's location shows that it has more protons than neutrons in its nucleus; hydrogen reacts with other elements until the number of electrons is reduced to equal the number of neutrons.

Standard: Use the periodic table as a model to predict the relative properties of elements based on the patterns of electrons in the outermost energy level of atoms.

Cognitive Complexity:

SEP: Low

DCI: Med

CCC: Med

Overall Cognitive Complexity: Moderate Support

Distractor Rationale:

- A. Correct.** Because hydrogen has one electron in its valence shell it is highly reactive, giving up this electron freely during reactions.
- B.** The student may think that hydrogen reacts to fill an octet.
- C.** The student may be confused about the relationship between neutrons and the organization of the periodic table and think that hydrogen reacts to balance protons to electrons.
- D.** The student may be confused about the relationship between neutrons and the organization of the periodic table and think that hydrogen reacts based on the numbers of neutrons and electrons.

Matter and Its Interactions: PS.PS1.2

back to "Item Specifications by Performance Expectation"

PS.PS1.2. Construct and revise an explanation for the outcome of a simple chemical reaction based on the outermost electron states of atoms, trends in the periodic table, knowledge of the patterns of chemical properties, and formation of compounds.

OAS-S Clarification Statement:

Identifying patterns in reactions allows the emphasis to be on student explanation of observed reaction outcomes. Reactions that students could be exposed to are synthesis (limited to elements forming a compound), decomposition (limited to a compound producing two or more elements), combustion, single displacement, or double displacement).

OAS-S Assessment Boundary:

Assessment is limited to chemical reactions involving main group elements.

Science & Engineering Practice:

Constructing Explanations

- Construct and revise an explanation based on valid and reliable evidence obtained from a variety of sources and the assumption that theories and laws that describe the natural world operate today as they did in the past and will continue to do so in the future.

Disciplinary Core Idea:

Structure and Properties of Matter

- The periodic table orders elements horizontally by the number of protons in the atom's nucleus and places those with similar chemical properties in columns. The repeating patterns of this table reflect patterns of outer electron states.

Chemical Reactions

- The fact that atoms are conserved, together with knowledge of the chemical properties of the elements involved, can be used to describe and predict chemical reactions.

Crosscutting Concept:

Patterns

- Different patterns may be observed at each of the scales at which a system is studied and can provide evidence for causality in explanations of phenomena.

In Lay Terms:

Students should be able to use evidence from multiple sources (including the periodic table and their knowledge of the patterns of chemical properties and formation of compounds) to explain how, why, whether or not, and/or under what conditions certain chemical reactions take place.

Cluster Clarifications:

- Does not include understanding of ionization energy and electronegativity because PS.PS1.1 does not require understanding.
- Limit reactions to those containing no more than two reactants and two products.
- For the purposes of this assessment, students are not responsible for classifying reactions. However, reaction types can be defined conceptually in the stimulus.
- Combustion reactions should be limited to those containing main group elements (e.g., hydrocarbons).
- Combustion reactions should be limited to smaller hydrocarbons (fewer than 8 carbon atoms).
- To allow equal access for physics students, focus phenomena on those taught in biology (e.g., carbon and oxygen, carbon and hydrogen).
- The structure of the periodic table must be referenced in stimulus (i.e., groups and periods defined).
- For the purposes of this assessment and this PE, reactivity is defined as the likelihood of an element to gain or lose electrons.
- To align to CCC, items may examine a phenomenon at two different scales or the cluster may examine a phenomenon at two different scales (macroscopic and microscopic).
- Equations must include both names of reactants/products and symbols.

Matter and Its Interactions: PS.PS1.2

Cluster Stimulus Attributes:

Typical stimulus elements:

- text descriptions and equations for chemical reactions
- diagrammatic models of reactions (e.g., Lewis structures for individual elements (not compounds), Bohr models, ball-and-stick models, space-filling models)
- data tables (e.g., for valence electrons, info about properties, conservation)

Possible contexts:

- combustion of butane
- $2\text{C}_4\text{H}_{10} + 13\text{O}_2 \rightarrow 8\text{CO}_2 + 10\text{H}_2\text{O} + \text{energy}$ (revise to combustion of butane)
- combustion of wood
- combustion of ethanol versus octane
- explain why the formation of NaCl generates heat
- explain why potassium and hydrogen can react similarly
- stabilization of lithium to produce compounds such as drugs
- why group I elements tend to bond with group VII elements
- red dirt in OK (oxidized iron; not a lot of reactive metals in OK soil because redoxed and oxidized over time, therefore must add fertilizer (which reacts readily with water and leads to acidification of water))
- why gold stays shiny
- baking soda and vinegar (conservation of mass experiment)
- tungsten as filament material
- wheels containing Mg are more likely to burn in car accidents

Content and evidence to be included: information/descriptions about the chemical reaction(s)

Types of student responses that need to be supported: explaining with evidence and reasoning; using evidence to make predictions; supporting and revising explanations based on valid and reliable evidence obtained from a variety of sources; determining which explanation is/is not supported by the evidence

Allowable Item Types:

- MC
- TEI

Model Item Descriptions for PS.PS1.2:

#	Item Type	Model Stem (Items ask students to...)	Response Characteristics*
1	MC	Use the periodic table to explain the difference in reactivity among elements. [(Table showing reaction of group 2 metals with HCl) What explains the difference in reaction results that the student observed?]	Distractors may include statements that do not sufficiently explain, statements that explain alternate phenomena, or statements lacking critical conceptual connections. Define reactivity in stimulus.
2	MC	Use the periodic table to make inferences about the valence electrons of elements.	Distractors may include unsupported inferences.
3	MC/ TE	Use data, models, and other evidence to predict the product that will form in a given reaction (i.e., provide the reasoning). [What product will form between X and Y?]	Distractors may include representations that include only a subset of data or which misinterpret data. Reactions must follow the exact same pattern in terms of valence electrons. TEI: Matching, drag-drop interactions.
4	MC	Describe the evidence that supports a given model. [How is the model showing differences in valence electrons supported by the difference in reactivities seen in the table?]	Distractors may include information that is irrelevant to the pattern analyzed.
5	MC	Determine which explanation for the outcome of a simple chemical reaction is supported/not supported by the data. [($2\text{Mg} + \text{O}_2 \rightarrow 2\text{MgO}$) How can the data be used to explain why this reaction occurs?] [Why is the product 2MgO ?] [How should this equation be revised and why?] [Which revision to the equation is best supported and why?]	Distractors may include explanations unsupported by the data or explanations that do not relate factors in an appropriate way. Stimulus should include data about valence electrons or information about conservation.
6	TE	Construct an explanation for the outcome of a simple chemical reaction by providing an explanation statement, evidence, and reasoning based on experimental data. [Identify an explanation, evidence, and reasoning for the process by which magnesium and oxygen form magnesium oxide.] [Identify an explanation, evidence, and reasoning for the differences in mass observed when baking soda is mixed with vinegar in an open versus closed system.]	Drag-drop interaction. Could also be completed with match or drop-down interaction in some cases. Item provides table/columns for placing and connecting explanation, evidence, and reasoning. Multiple pieces of evidence/reasoning could be required. Correct responses show accurate identification and association of explanation, evidence, and reasoning. Partial credit would be awarded for a subset of correct responses. Data may include mass.

#	Item Type	Model Stem (Items ask students to...)	Response Characteristics*
7	MC	Describe the cause-effect relationship between patterns of reactivity of elements and their relative electronegativity. [(Selecting a material for a particular use; for example, wheels containing magnesium are likely to burn) What relationship can be described between the reactivity of the metals tested in this experiment and their electronegativities?]	Distractors may include statements that do not sufficiently explain, statements that explain alternate phenomena, or statements lacking critical conceptual connections. Define reactivity in stimulus.
8	MC	Revise an explanation about the outcome of a chemical reaction to incorporate additional evidence. [How should the explanation be adjusted to account for this additional evidence?]	Key may focus on a revision that adds detail, clarity, or additional data support to the explanation. Additional evidence may include masses, valence electrons, chemical properties including flammability, heat of combustion. Distractors may include explanations that detract from or reduce the value of the given explanation or explanations that add information but do not logically account for all of the referred to data.
9	MC	Revise an explanation about the outcome of a chemical reaction to correct conceptual misunderstandings. [What was the mistake in the student's thinking and what change to the equation will fix it?] [(Open and closed system) Where did the mass go?]	Key may focus on a revision that adds clarity to the explanation. Distractors may include explanations that detract from or reduce the value of the given explanation or explanations that add information but do not correct an identified misconception. Students are not responsible for knowing formulas of compounds. Pictorial representations should be used.
10	MC	Justify a revision to an explanation by accounting for the additional information incorporated in the explanation. [How does the additional evidence (e.g., about the difference in mass between the open and closed system—second piece of evidence is pictorial equation) justify the revision to the students' explanation?]	Key may focus on a justification that adds clarity to the explanation while accounting for additional information. Distractors may include justifications that do not add clarity, which reduce the value of the given explanation, or which incompletely account for additional data.

Student Misconceptions:

*Response options can make use of Student Misconceptions (examples of scientifically incorrect assumptions) related to this performance expectation; references to misconceptions are listed in the links below:

- The periodic table provides only an element's name, symbol, atomic number, and atomic mass.
- The more subatomic particles contained in an atom, the larger the atom.
- When the total number of electrons is changed in the atom, periodic properties do not change.
- Molecules form from isolated atoms.
- Electrons have a positive charge.
- In a closed system, the total mass increases during a precipitation reaction.
- In a closed system, mass decreases after a solid dissolves in a liquid.
- When a chemical reaction occurs, matter just disappears. For example, gasoline is used up in the car and disappears.
- Matter can disappear with repeated division, dissolving, evaporation, or chemical change.

From onlinelibrary.wiley.com/doi/10.1002/tea.3660290203/full

- Students misuse atomic mass when analyzing patterns of reactivity from the periodic table.

Matter and Its Interactions: PS.PS1.5*

back to “Item Specifications by Performance Expectation”

PS.PS1.5. Apply scientific principles and evidence to provide an explanation about the effects of changing the temperature or concentration of the reacting particles on the rate at which a reaction occurs.

OAS-S Clarification Statement:

Emphasis is on student reasoning that focuses on the qualitative evidence for number and energy of collisions (Collision Theory) and relationships between rate and temperature.

OAS-S Assessment Boundary:

Assessment is limited to explaining the result of changing one condition at a time in a simple reaction in which there are only two reactants.

Science & Engineering Practice:

Constructing Explanations

- Apply scientific reasoning, theory, and/or models to link evidence to the claims to assess the extent to which the reasoning and data support the explanation or conclusion.

Disciplinary Core Idea:

Chemical Reactions

- Chemical processes, their rates, and whether or not energy is stored or released. These can be understood in terms of the collisions of molecules and the rearrangement of atoms into new molecules, with consequent changes in the sum of all bond energies in the set of molecules that are matched by changes in kinetic energy.

Crosscutting Concept:

Cause and Effect

- Cause and effect relationships can be suggested and predicted for complex natural and human designed systems by examining what is known about smaller scale mechanisms within the system.

In Lay Terms:

Students should be able to explain that the rate, or how fast a chemical reaction occurs, is determined by the collisions of the molecules that make up the chemical reaction and how much energy is in those collisions. The number of collisions that occur during a chemical reaction can be influenced by temperature as well as the amount of particles present during a chemical reaction.

Cluster Clarifications:

- Catalysts are beyond the scope of this assessment.
- The scientific principles to be applied in explanations include: the kinetic molecular theory (students are responsible for concept but not the name of this theory); movement of heat.
- Concentrations should be expressed in grams per liter, parts per million, etc., not moles/molarity.
- Equations must include both names of reactants/products and symbols.
- The term “precipitant” should not be used. Rather, use “solid,” or “product.”

**associated sample cluster included*

Matter and Its Interactions: PS.PS1.5*

Cluster Stimulus Attributes:

Typical stimulus elements:

- models and diagrams
- data tables and graphs
- scientific reports or summaries
- pictures/drawings of reactions under different conditions

Possible contexts:

- using a spectrometer to measure reaction between food dye and bleach
- rate of reaction of antacids in cold and hot water
- rate of reaction of baking soda and vinegar at different concentrations of each reagent
- change in brightness of glow stick at different temperatures as measured by light meter
- rate of reaction of potassium iodate with sodium bisulfate
- potassium permanganate and oxalic acid reaction (measure time it takes color to change)
- sodium thiosulfate plus hydrochloric acid
- decomposition of sodium peroxide (change in mass)
- reaction of magnesium metal and different concentrations of HCl
- mercury and aluminum (removal of aluminum oxide so that reaction can begin)
- bromothymol blue as indicator for CO₂
- factors affecting the spherification process (food science)
- organic peroxides in industrial setting and issues during power losses due to need to cool (do not reference Hurricane Harvey)
- recovery of athletes in hyperbaric chambers (recovery times of muscles)
- cryotherapy
- torpor in hummingbirds and small mammals
- effect of photoperiod on starlings and other organisms
- baking
- design problems: manipulating limestone content to produce concrete that is more resistant to weathering; when to speed up or slow down rate of weathering
- galvanizing metal to slow down rate of reaction
- salt in winters and rusting of cars (Is it temperature variant? Does it get worse during melt?)
- absolute zero and movement of molecules
- slowing metabolism in Greenland sharks
- thermite reaction (reaction of rusted ball bearing and bearing wrapped in aluminum foil)
- fizzy bath bombs and water
- hydrogen bombs
- deep water vents and density-dependent accretion of chimneys (black smokers)
- other extremophiles
- differential corrosion in the Baltic sea

Content and evidence to be included: graphs showing increase in temperature or increase in concentration versus change in product; images of reactions at different concentrations/temperatures; design problem to analyze

Types of student responses that need to be supported: applying scientific principles to construct explanations, including analyzing the evidence for the explanation

Allowable Item Types:

- MC
- TEI

Model Item Descriptions for PS.PS1.5:

#	Item Type	Model Stem (Items ask students to...)	Response Characteristics*
1	MC	Describe or explain cause-and-effect relationships pertaining to concentration/temperature and reaction rate/collisions of molecules. [Which statement explains the relationship between temperature and number of collisions between molecules?] [Which statement explains the relationship between concentration and number of collisions between molecules?]	Key may focus on processes or steps in the cause-effect chain of events. Distractors may include statements that do not sufficiently explain, statements that explain alternate phenomena, or statements lacking critical conceptual connections.
2	MC	Explain through a model or models the effects of changing temperature or concentration of the reacting particles on the rate at which a reaction occurs. [Based on the data, which model of particle motion shows how temperature affects the way that products form?]	Models may be atomic/molecular, conceptual, or mathematical (i.e., tables showing mathematical relationships, or equations). Distractors may include models with unrelated molecules.
3	MC	Identify/use evidence to support an explanation of relationships pertaining to concentration/temperature and reaction rate/collisions of molecules. [What evidence supports the students' explanation for how concentration is related to rate of reaction?]	Key may include evidence such as production of gas, amount of precipitant (solid), reaction time, color changes, etc. Distractors may include data that do not provide sufficient/valid evidence or data related to processes. The term "precipitant" should not be used; Rather use "solid" or "product."
4	MC	Develop an explanation (text-based) for the effects of changing temperature or concentration of the reacting particles on the rate at which a reaction occurs. [Which explanation for how concentration of reactants affects the rate of the reaction is supported by the data?] [Which explanation for how temperature of reactants affects the rate of the reaction is supported by the data?]	Items should be limited to common examples containing only two reactants. Distractors may include explanations of alternate mechanisms.
5	TE	Complete a model/diagram to explain the effects of changing temperature or concentration of the reacting particles on the rate at which a reaction occurs. [Complete the model to show how increasing temperature produces the results seen in the data table/graph.] [Complete the sequence to show how increasing concentration affects the number of collisions between molecules.]	Drag-drop interaction. Could also be done using drop-down or match interaction. Item may have more draggable options/choices than are needed to construct the model explanation. Items should address interactions that cannot be easily illustrated in static examples or are too complex to explain in a multiple-choice item. Correct responses show all products requested. Partial credit would be awarded for a subset of correct responses.

#	Item Type	Model Stem (Items ask students to...)	Response Characteristics*
6	MC	<p>Develop a molecular explanation for a real-world/macro observation or phenomenon based on the evidence.</p> <p>[Which statement best explains why the contents of the first test tube took 5 minutes to change color, but the contents of the second test tube took 1 minute to change color?]</p>	<p>Key may focus on explanation of the macro observation or phenomenon based on interpreting the reaction occurring in terms of collisions.</p> <p>Distractors include statements explaining reasoning for other outcomes or erroneous explanations for the observation or phenomenon.</p> <p>Experimental design must be included; for example, constants, differences in pressure, temperature, etc. May use diagrams or data tables to show setup.</p>
7	MC	<p>Connect reasoning to the evidence that concentration/temperature affect reaction rate/collisions of molecules (i.e., how the data support the particular explanation).</p> <p>[Which statement best describes the reason for the difference in color for the contents of test tubes 1 through 10?]</p> <p>[How does the evidence support the student's claim that at higher temperatures molecules are more likely to collide?]</p> <p>[How does the evidence support the claim that higher concentrations mean more particle collisions in a given amount of time?]</p> <p>[How does the evidence support the students' claim that at a given concentration, molecules with higher kinetic energy collide more often?]</p> <p>[How does the evidence support the idea that collisions at higher temperatures are more likely to result in a chemical reaction?]</p>	<p>Key may focus on a particular chemical reaction that illustrates the effect of increasing temperatures/concentration of reactants.</p> <p>Distractors may include statements including invalid/unsupported reasoning or reasoning for alternate phenomena, incorrect data interpretations, and/or misconceptions.</p> <p>Experimental design must be included; for example, constants, differences in pressure, temperature, etc. May use diagrams or data tables to show setup.</p>
8	MC	<p>Provide evidence-based clarification/additional data to improve an explanation pertaining to concentration/temperature and reaction rate/collisions of molecules.</p> <p>[Based on the evidence, which additional statement/clarification will best improve the students' explanation for the results seen in the experiment?]</p>	<p>Distractors may include information/data/trivial statements that do not provide an improved explanation.</p>
9	MC	<p>Explain how the data show that changing the temperature or concentration of reacting particles results in changes in the rate at which a reaction occurs.</p> <p>[Which statement best explains what the data illustrate about how changes in concentration of reactants affect reaction rate?]</p>	<p>Key may focus on relationship between temperature and energy of collisions, or concentration and likelihood of collisions.</p> <p>Data may include temperature versus reaction time, temperature versus gas released, temperature versus product, or qualitative results.</p>

#	Item Type	Model Stem (Items ask students to...)	Response Characteristics*
9 cont.	MC	<p>[How does the data support the idea that as temperature increases, more collisions are occurring?]</p> <p>[Based on the graph (temperature versus reaction time) which conclusion/explanation best reflects the data?]</p> <p>[How is an increase in temperature to X likely to affect reaction rate?]</p> <p>[Based on the data, what can be done to increase the reaction rate?]</p> <p>[Based on the data, should more or less of reactant A be added to the system? (plus reasoning)]</p>	
10	TE	<p>Construct an explanation for the effects of changing temperature or concentration of the reacting particles on the rate at which a reaction occurs by providing an explanation statement, evidence, and reasoning based on experimental data.</p> <p>[Describe the explanation, evidence, and reasoning for a process by which increasing temperature affects the rate of a chemical reaction.]</p> <p>[Select all the possible changes in the experimental design that would cause an increase in hydrogen gas.]</p>	<p>Drag-drop or hot-spot interaction.</p> <p>Could also be completed with matching or drop-down interaction in some cases.</p> <p>Item provides table/columns for placing and connecting explanation, evidence, and reasoning.</p> <p>Multiple pieces of evidence/reasoning could be required.</p> <p>Correct responses show accurate identification and association of explanation, evidence, and reasoning.</p> <p>Partial credit would be awarded for a subset of correct responses.</p> <p>For hot-spot, a maximum of 6 choices, with 3 correct.</p>

Student Misconceptions:

*Response options can make use of Student Misconceptions (examples of scientifically incorrect assumptions) related to this performance expectation; references to misconceptions are listed in the links below:

- A chemical reaction always happens when two substances are combined together.
- A chemical change is irreversible.
- A solid substance is always formed during a chemical reaction.
- The average speed of the atoms or molecules of a substance remains the same with a change in temperature.
- The average speed of the atoms or molecules of a substance decreases when the temperature increases and increases when the temperature decreases.
- Increasing the speed of the atoms or molecules of a substance does not change the temperature of the substance.

From modeling.asu.edu/modeling/KindVanessaBarkerchem.pdf

- All collisions result in a chemical reaction.
- During a chemical reaction, the original substance vanishes.

Sample Cluster for PS.PS1.5

Use the information to answer the following questions.

A student cleans a tarnished silver ring by placing it in a solution of baking soda, salt, and water. After several hours, the ring is clean. She then decides to clean a necklace using twice the amount of baking soda and salt in her mixture. The necklace is clean after only 15 minutes.

The student investigates whether concentration affects the time of other chemical reactions. She chooses to observe different concentrations of sodium thiosulfate ($\text{Na}_2\text{S}_2\text{O}_3$) solution reacting with a 7.29% hydrochloric acid (HCl) solution. This reaction forms sulfur and sulfur dioxide.

The student makes this claim:

As the concentration of $\text{Na}_2\text{S}_2\text{O}_3$ increases, the reaction with HCl will take less time.

The student carefully measures different concentrations of sodium thiosulfate ($\text{Na}_2\text{S}_2\text{O}_3$) solutions into five separate beakers. She then adds 10 mL of the HCl solution (excess reactant) and records the time of each reaction. An excess reactant is defined as a chemical that has some left over after all the other chemicals have reacted. The student records data in the table, showing the percent concentration of $\text{Na}_2\text{S}_2\text{O}_3$ in each beaker.

$\text{Na}_2\text{S}_2\text{O}_3$ Reaction Times

Beaker	$\text{Na}_2\text{S}_2\text{O}_3$ Concentration (%)	Reaction Time (s)
1	2.37	22.3
2	1.90	27.5
3	1.42	35.0
4	0.948	60.1
5	0.474	159.0

The student graphs the data as shown.

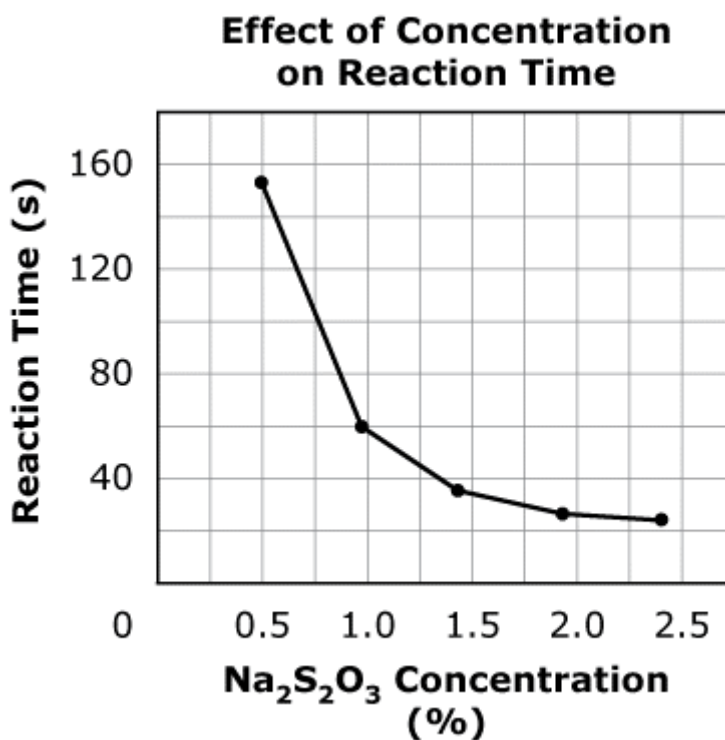

The student attempts to explain her observations using particle collision theory. The collision theory states that the rate of a chemical reaction depends on three factors:

- Number of collisions per second
- Number of collisions with enough energy to react
- Number of collisions with the proper orientation, allowing the particles to react

(Items on the following pages)

1 How do the data about higher concentration levels support particle collision theory?

- A** An increased reaction rate shows that the number of collisions per second increases when more particles are present.
- B** A decreased reaction rate shows that the number of collisions per second decreases when particles of different substances are mixed.
- C** An increased reaction rate shows that the number of collisions with enough energy to react increases when the particles are farther apart.
- D** A decreased reaction rate shows that the number of collisions occurring with the proper orientation decreases when particles are dissolved in solution.

Standard: Apply scientific principles and evidence to provide an explanation about the effects of changing the temperature or concentration of the reacting particles on the rate at which a reaction occurs.

Cognitive Complexity:

SEP: Medium

DCI: Medium

CCC: Medium

Overall Cognitive Complexity: Moderate Support

Distractor Rationale:

- A. Correct.** The higher concentration causes particle spacing to be denser, resulting in a greater overall number of collisions, and thus a higher number of collisions with enough energy to facilitate a reaction.
- B.** The reaction rate increased at higher concentrations.
- C.** Increase in concentration doesn't mean an increase in energy. Particles being farther apart would decrease the reaction rate.
- D.** The reaction rate increased at higher concentrations.

2 Based on the graph, which statement describes how the reaction time would change if the concentration of $\text{Na}_2\text{S}_2\text{O}_3$ was changed to 4.74%?

- A** Reaction time would decrease because it is dependent on the concentration of $\text{Na}_2\text{S}_2\text{O}_3$.
- B** Reaction time would not change because it is independent to the concentration of HCl.
- C** Reaction time would increase because it is dependent on the concentration of $\text{Na}_2\text{S}_2\text{O}_3$.
- D** Reaction time would not change because it is independent of the concentration of either reactant.

Standard: Apply scientific principles and evidence to provide an explanation about the effects of changing the temperature or concentration of the reacting particles on the rate at which a reaction occurs.

Cognitive Complexity:

SEP: Medium

DCI: Medium

CCC: Medium

Overall Cognitive Complexity: Moderate Support

Distractor Rationale:

- A. **Correct.** Reaction time will decrease when the concentration of $\text{Na}_2\text{S}_2\text{O}_3$ increases.
- B. The concentration of HCl is constant in this investigation.
- C. Reaction time would decrease if the concentration was increased.
- D. Reaction time is dependent on the concentration of reactants.

3 Which statement best explains the trend related to reaction time shown in the data table?

- A As concentration increases, reactant particles speed up.
- B As concentration decreases, reactant particles collide less often.
- C As concentration decreases, reactant particles take up more space.
- D As concentration increases, reactant particles collide with more force.

Standard: Apply scientific principles and evidence to provide an explanation about the effects of changing the temperature or concentration of the reacting particles on the rate at which a reaction occurs.

Cognitive Complexity:

SEP: Medium

DCI: Medium

CCC: Medium

Overall Cognitive Complexity: Moderate Support

Distractor Rationale:

- A. Concentration does not affect the speed of particles.
- B. **Correct.** Dilution causes fewer collisions, resulting in an increase in reaction time.
- C. Fewer particles are less likely to interact because there is more space between them.
- D. Concentration does not alter the force of collisions.

Matter and Its Interactions: PS.PS1.7

back to “Item Specifications by Performance Expectation”

PS.PS1.7. Use mathematical representations to support the claim that atoms, and therefore mass, are conserved during a chemical reaction.

OAS-S Clarification Statement:

Emphasis is on using mathematical ideas to communicate the proportional relationships between masses of atoms in the reactants and the products, and the translation of these relationships to the macroscopic scale. Mathematical representation can include balancing chemical equations to represent the laws of conservation of mass, constant composition (definite proportions) and understanding the ratio of the coefficients between reactants and products.

OAS-S Assessment Boundary:

Assessment does not include complex chemical reactions or stoichiometry. Emphasis is on assessing students' use of mathematical reasoning and not on memorization and rote application of problem-solving techniques.

Science & Engineering Practice:

Using Mathematics and Computational Thinking

- Use mathematical representations of phenomena to support claims.

Disciplinary Core Idea:

Chemical Reactions

- The fact that atoms are conserved, together with knowledge of the chemical properties of the elements involved, can be used to describe and predict chemical reactions.

Crosscutting Concept:

Energy and Matter

- The total amount of energy and matter in closed systems is conserved.

In Lay Terms:

Students should be able to use mathematical representations to support the following claims:

- There is equality between the mass of the atoms in the reactants and the mass of the atoms in a product.
- The number of atoms that make up a specific mass can be used to relate the conservation of mass predicted at the atomic scale to the data seen at the macroscopic scale.

Cluster Clarifications:

- The rote process of balancing of equations is not the focus of this PE. The focus is the conceptual understanding that mass is conserved during reactions.
- For pre-balanced equations, limit reactions to those containing no more than a total of four reactants and products, and no more than six elements.
- The word “mole” should be defined as a specific quantity of particles. Avogadro’s number may be introduced in stimuli but may not be used in stoichiometric calculations (moles to moles).
- For students to do conversions, necessary data must be included in a data table (atoms to moles, or grams to moles, but not moles to moles).
- Avoid formulas containing multiple polyatomic ions (e.g., $\text{Ca}(\text{NO}_3)_2$) or $(\text{NH}_4)_2\text{CO}_3$.

Limit balancing of equations to the following reaction types: single displacement, decomposition, and synthesis. (Note that students are not responsible for knowing the names of these reactions types, and reactions should be placed within the context of a real-world, engaging phenomenon.)

- Reactions may include:
 - $2\text{H}_2 + \text{O}_2 \rightarrow 2\text{H}_2\text{O}$
 - $2\text{H}_2\text{O}_2 \rightarrow 2\text{H}_2\text{O} + \text{O}_2$
 - $2\text{Na} + \text{O}_2 \rightarrow 2\text{Na}_2\text{O}$
 - $\text{P}_4 + 3\text{O}_2 \rightarrow \text{P}_4\text{O}_6$
 - $\text{C} + 2\text{H}_2 \rightarrow \text{CH}_4$
 - $2\text{Al}_2\text{O}_3 \rightarrow 4\text{Al} + 3\text{O}_2$
 - $\text{Mg} + 2\text{HCl} \rightarrow \text{MgCl}_2 + \text{H}_2$

Matter and Its Interactions: PS.PS1.7

- $\text{Cl}_2 + \text{KI} \rightarrow \text{KCl} + \text{I}_2$
- $2\text{Na} + 2\text{HCl} \rightarrow \text{H}_2 + 2\text{NaCl}$
- Mathematical representations include balanced chemical equations, pictorial representations, or tables/charts of mass or particle data.
- Limiting reactants are not in the scope of this assessment.
- Catalysts are not in the scope of this assessment.
- The terms “matter” and “mass” are not to be used interchangeably in the same cluster.
- Use the term “reactant,” not “reagent.”
- Do not account for energy in chemical equations.
- Students are not responsible for calculating percent error, but are responsible for analyzing causes/sources of error conceptually.

Cluster Stimulus Attributes:

Typical stimulus elements:

- graphs
- diagrams
- text descriptions
- tables
- chemical equations
- experimental data

Possible contexts:

- synthesis of water (Mars)
- decomposition of water, hydrogen peroxide
- decomposition of carbonic acid in soft drinks: $\text{H}_2\text{CO}_3 \rightarrow \text{H}_2\text{O} + \text{CO}_2$
- simple synthesis, decomposition, single reactions
- Statue of Liberty gaining mass as it oxidizes
- ozone depletion or regeneration
- oxygen generation
- carbon sequestration
- Apollo carbon dioxide scrubber
- steel wool ignited with 9-volt battery gaining mass
- buildings with exposed metal changing mass
- tombstones losing mass
- Michelangelo’s statues losing mass versus Statue of Liberty gaining mass
- log burning produces tiny pile of ash. (How do you account for rest of the log? [Need to limit to mass, not energy release.] Do younger logs produce less ash?)
- assembly lines

Content and evidence to be included: graphs, tables, equations, or other relevant information about reactants and products of a chemical reaction

Types of student responses that need to be supported: identifying claims supported by mathematical relationships; making conclusions or claims about mathematical relationships; relating mathematical relationships to claims; using mathematical data to support claims; using mathematical relationships to make predictions and calculations/conversions

Allowable Item Types:

- MC
- TEI

Model Item Descriptions for PS.PS1.7:

#	Item Type	Model Stem (Items ask students to...)	Response Characteristics*
1	MC	<p>Choose the most appropriate mathematical representation for parts or relationships in a system showing conservation during a chemical reaction.</p> <p>[Which representation best shows the change in reactants and products in this system over time?]</p>	<p>Key may focus on the mathematical representation that best illustrates the specified parts or relationships.</p> <p>Distractors may include expressions that contain a subset of the factors seen in the correct expression or that contain similar but not identical factors.</p>
2	MC	<p>Make a conclusion or claim describing what the mathematical representation shows about conservation of atoms and/or mass.</p> <p>[Which statement best describes what the graph shows about the relationship between reactants and products as this reaction proceeds?]</p> <p>[Based on the information shown in the formula and data table, how much calcium carbonate was produced in this reaction?]</p>	<p>Key may focus on describing what the representation illustrates overall about conservation of atoms and mass.</p> <p>Distractors may include unsupported claims, or claims that misstate the proportional relationships between masses of atoms in reactants and products and or misunderstanding of the idea of the mole as a link between the atomic/molecular and macroscopic scales.</p>
3	MC	<p>Identify which claim about relationships between products and reactants is supported based on the mathematical representation.</p> <p>[Which claim about the products and reactants in this reaction is supported, based on the information shown in the table?]</p>	<p>Key may focus on a claim comparing the molar masses of products versus reactants, the amount of a specific product to be produced, or differences between experimental and theoretical yields (conceptual analysis only).</p> <p>Distractors may include claims unsupported by the data or irrelevant to the matter or energy concept.</p>
4	MC	<p>Relate the mathematical representation to the claim/describe how the mathematical representation links to the concept (in the claim).</p> <p>[How does the information shown in the table/graph/equation relate to the student's claim about the relationships between the number of atoms in the reactants versus the number of atoms in the products?]</p> <p>[How does the data support the claim that the number of atoms in a system does not change during a chemical reaction?]</p> <p>[How do the (non-stoichiometric) calculations support the claim that matter is conserved in this reaction?]</p>	<p>Key may focus on how the mathematical representation provides support for the concept presented in the claim (reasoning with content).</p> <p>Distractors may include explanations that misinterpret the relationship described in the expression or representation.</p>
5	MC	<p>Use mathematical data to select/support a claim about the relationships among reactants and/or products.</p> <p>[Based on the data (showing numerical calculations of molar mass), which claim about the relationship between reactants and products is supported?]</p>	<p>Key may focus on correlations.</p> <p>Distractors may include statements describing inverse/tangential/irrelevant relationships to those seen in the data (per common misconceptions) or comparisons of uncorrelated data.</p>

#	Item Type	Model Stem (Items ask students to...)	Response Characteristics*
6	MC	Use data to support claims related to the relationship between masses of atoms in reactants and products. [Which data supports the students' claim that there is a direct relationship between the amount of oxygen reacted and the amount of water produced?]	Key may focus on data directly supporting the claim, such as data showing a proportional relationship between variables. Distractors may include data from sets including confounding variables.
7	TE	Given a mathematical representation and a list of claims about changes to atoms/mass after a chemical reaction, distinguish those that are supported from those that are unsupported by the given representation. [Select all of the claims about changes to atoms/mass that are supported by the mathematical model the scientists created.]	Interaction type may be drag-drop (sorting which claims are supported) or drop-down (menus for evaluating each claim). Claims to evaluate may include those that represent misconceptions or invalid interpretations of the data. Claims should focus on conservation of mass and atoms, etc. Correct responses show the multiple claims that are supported by the data. Partial credit would be awarded for a subset of correct responses.
8	MC	For a given chemical reaction, use a mathematical representation to calculate the mass of a component of the reaction when given the mass of other components of the reaction. [Which equation shows how to determine the number of grams of oxygen produced in this reaction?]	Distractors may include comparative values based on common misconceptions or common application errors. All other data must be supplied in the stimulus/item.

Student Misconceptions:

*Response options can make use of Student Misconceptions (examples of scientifically incorrect assumptions) related to this performance expectation; references to misconceptions are listed in the links below:

- Mass is not conserved during processes in which gases take part.
- If a gas is produced during a chemical reaction that takes place in a closed system, the total mass decreases.
- In a closed system, the total mass increases during a precipitation reaction.
- In a closed system, mass decreases after a solid dissolves in a liquid.
- When a chemical reaction occurs, matter just disappears. For example, gasoline is used up in the car and disappears.
- Mass increases after a solid dissolves in a liquid.
- Matter can disappear with repeated division, dissolving, evaporation, or chemical change.

Motion and Stability: Forces and Interactions: PS.PS2.5*

back to “Item Specifications by Performance Expectation”

PS.PS2.5. Plan and conduct an investigation to provide evidence that an electric current can cause a magnetic field and that a changing magnetic field can cause an electric current.

OAS-S Clarification Statement:

Students’ investigations should describe the data that will be collected and the evidence to be derived from that data. Examples could include electromagnets/solenoids, motors, current carrying wires, and compasses.

OAS-S Assessment Boundary:

Assessment is limited to planning and conducting investigations with provided materials and tools.

Science & Engineering Practice:

Planning and Carrying Out Investigations

- Plan and conduct an investigation individually and collaboratively to produce data to serve as the basis for evidence, and in the design: decide on types, how much, and accuracy of data needed to produce reliable measurements and consider limitations on the precision of the data (e.g., number of trials, cost, risk, time), and refine the design accordingly.

Disciplinary Core Idea:

Types of Interactions

- Forces at a distance are explained by fields (gravitational, electric, and magnetic) permeating space that can transfer energy through space.
- Magnets or electric currents cause magnetic fields; electric charges or changing magnetic fields cause electric fields.

Definitions of Energy

- “Electrical energy” may mean energy stored in a battery or energy transmitted by electric currents.

Crosscutting Concept:

Cause and Effect

- Empirical evidence is required to differentiate between cause and correlation and make claims about specific causes and effects.

In Lay Terms:

Forces acting at a distance provide evidence for the existence of magnetic or electric fields. Students should be able to describe how to carry out investigations that help demonstrate the following:

- Magnets and electrical currents produce magnetic fields that can apply a force.
- Electrical charges and changing magnetic fields produce electric fields that can apply a force.
- Forces acting at a distance transfer energy through space.

Cluster Clarifications:

- Although this PE asks students to plan and conduct an investigation, the focus of the assessment is not controlling variables, identifying hypotheses, or performing other steps of the scientific method. Rather, it extends into using data as evidence to refine designs considering the reliability, accuracy, and limitations of the data collected.
- Students are not responsible for labeling variables as independent or dependent. (i.e., do not ask, “What is the independent variable?” Rather, examine the relationship between variables.)
- Descriptions of relationships between variables should not use the traditional if/then hypothesis format.
- Simple circuits should be provided for demonstration purposes, not for manipulation.
- Units: stimuli should define units used. Use “tesla” to describe magnetic field strength. Use “amps” to describe current. Use “newtons” to describe force. Use “joules” to describe energy. Use “volts” to describe electric field.
- Instead of using specific units, items may describe forces conceptually.
- Induced charge is within the scope of this assessment, but other aspects of inductance (e.g., metal detector) are beyond the scope of this assessment.
- Energy stored in batteries is beyond the scope of this assessment.
- AC current is beyond the scope of this assessment.
- Items should not include calculations/analysis of input/output efficiency.

Motion and Stability: Forces and Interactions: PS.PS2.5*

- Investigations must provide evidence for and test mathematical, conceptual, physical, and empirical models.
- Exclude specifics about mechanics of tools/tool usage or identification of tools.
- Students may apply the use of significant figures to evaluate evidence, but significant figures should not be the main focus of the item.

Cluster Stimulus Attributes:

Typical stimulus elements:

- diagrams
- tables
- text descriptions of experimental designs that can be evaluated for design problems
- images
- graphs
- experimental data

Possible contexts:

- simple electromagnets
- voice coil applications
 - speaker
 - speaker + computer fan
- solenoid applications
- hand crank flashlight/radio/generator
- bicycle DIY dynamo
- bicycle battery-free headlight
- homopolar motor
- electric train
- electric motor
- aurora borealis
- southern lights
- rail gun (simple applications)
- high speed train (simple applications)
- gravity wave observatory (LIGO) (simple applications)
- Tesla coil
- magnetosphere
- high power line repair from helicopters
- solar flares
- EMPs
- slot cars
- electric railway cars
- using compass to detect magnetic fields induced by electricity from household/classroom electronics (including cell phone)

Content and evidence to be included: graphs, data charts, tables, or other relevant information about the investigation and data not presented in the stimulus; information that enables refinement of design or that highlights limitations

Types of student responses that need to be supported: evaluating, refining, and using evidence to justify experimental designs; examining accuracy/reliability/limitations of data; controlling variables that will affect the reliability/accuracy of data

Allowable Item Types:

- MC
- TEI

**associated sample cluster included*

Model Item Descriptions for PS.PS2.5:

#	Item Type	Model Stem (Items ask students to...)	Response Characteristics*
1	MC	Describe the steps in an investigation (e.g., of change in magnetic field as electric current changes) that produce the most useful results. [Which procedure should follow step 4 in this investigation?] [Which step should be added to make sure the results are reliable?] [Which step(s) should students include in their procedure to ensure that they gain the evidence required?]	Key may incorporate both an understanding of the process steps (observing all trials/control, when to observe) and characteristic results of the phenomenon being investigated. Distractors may include orders or descriptions that focus on the incorrect question/hypothesis, or misconceptions about the mechanism of the phenomenon being investigated.
2	TE	Complete the procedure for an investigation. [Select the best steps to complete the experimental procedure.]	Drag-drop interaction. The stimulus should contain data for students to analyze to determine the best procedural steps to produce reliable data. Two goals should be used with 4–6 draggers to choose from.
3	MC	Select which (dependent) variable to measure to gather data about how the experimental system will respond to a change in a(n) (independent) variable. [What measurement or observation will provide data to best help answer the research question?] [What is the most likely reason that a change in a variable did not affect the system? OR What change will not affect the system?] [How should the students modify the procedure/setup/circuit to double the number of paper clips picked up by the electromagnet?]	The system being studied should examine the interaction of magnetic field and electric current/magnets. Distractors may include misunderstandings of the cause-and-effect relationship between the independent and dependent variables, or between the dependent variable and other variables.
4	MC	Identify the problem of a detailed investigation about the relationship between electric currents and magnetic fields. [Which is being investigated by the setup/procedure shown?] [What problem are the students trying to solve?]	Key may focus on the dependent variable's response to the intended change in the independent variable. Distractors may include variables or predictions that do not connect the relevant cause-effect pattern. Descriptions of relationships between variables should not use the traditional if/then hypothesis format. Engineering design contexts may work well for this model stem.
5	MC	Based on supplied data/observations, identify the phenomenon being investigated. [Which statement best describes the phenomenon being investigated by gathering the data in Table 1?]	Distractors may include related phenomena that cannot be investigated with the data or observations supplied.

#	Item Type	Model Stem (Items ask students to...)	Response Characteristics*
6	MC	Describe the data/observations that would support the purpose of an investigation or claim being investigated. [(Aurora borealis data) Which of the following observations would provide evidence that there is a direct relationship between the location of a magnetic field and the movement of electrons through the atmosphere?]	Distractors may include descriptions of related claims that cannot be investigated (or may be only partially investigated) with the data or observations supplied.
7	MC	Critique an investigation for inaccuracies, limitations, or flaws in procedures, or expected results considering the question or hypothesis. [Which statement best explains why the data from the table may not be reliable to answer the question being investigated?] [Which statement best explains why the data from the table does not provide evidence to answer the question being investigated?]	Items should incorporate elements of content misconceptions in addition to consideration of varying degrees of impact of the investigative shortcomings on the results. Distractors may include steps/procedures that do not significantly affect results or conclusions.
8	MC	Describe the investigation plan that will provide the most useful evidence to answer a given question or support/reject a claim related to changes in magnetic fields produced by magnetic or electric currents. [Which investigation plan should the students use to demonstrate the idea that the strength of a magnetic field is related to the current passing through the coil?]	Distractors may include irrelevant steps or process that will be less useful in providing data to answer the question or support/reject the claim.
9	MC	Modify an investigation plan (e.g., to improve quality of data) to produce data to support a given claim related to changes in magnetic fields produced by magnets or electric currents. [Which of the following shows how to modify the investigation/plan/procedure to test whether the wire thickness affects the strength of a magnetic field?] [How should the students modify their investigation to increase the validity of their conclusion about the effect of wire thickness/ number of turns on a magnetic field?]	Distractors may include modifications that will make the data less useful in supporting the claim or will add procedures irrelevant to supporting the claim. This may include increasing the number of trials while introducing uncontrolled variables, limiting uncontrolled variables while also decreasing the number of trials, or increasing the amount of data collected while reducing the number of trials for each factor tested.
10	MC	Explain how the manipulation of one or more procedures would be expected to influence the result of an investigation of the relationship between magnetic fields and electric currents. [What would taking measurements more often show about the relationship of the dependent variable to field strength?]	Key may focus on impacts of changes in procedures on the dependent variable or on the significance of the data relative to the hypothesis. Distractors may include statements that reveal an incorrect understanding of how the procedure influences the results. Exclude specifics about mechanics of tools/tool usage.

#	Item Type	Model Stem (Items ask students to...)	Response Characteristics*
11	TE	<p>Given a diagram of an electromagnetic system, decide on types of data, how much data, and the accuracy of data needed to produce reliable measurements that show how the system changes in response to changes in one independent variable.</p> <p>[Identify the type of data, how much data, and the accuracy of data needed to provide reliable measurements to support the claim that the number of loops/diameter of the single loop will affect the strength of the magnetic field.]</p>	<p>Drop-down interaction.</p> <p>Include menus placed strategically on labels of the diagram of the system, such that at each point students decide one of the three data dimensions (i.e., type, how much, accuracy).</p> <p>Menus should contain one example of each data dimension (only one correct dimension) plus 1–3 extraneous dimensions.</p> <p>Correct responses will show all selections correctly.</p> <p>Partial credit would be given for a subset of correct responses.</p> <p>Stimulus must include data showing manipulation of thickness, number of turns, diameter of loops, etc., related to magnetic field strength.</p>
12	MC	<p>Describe characteristics of procedures that distinguish causal from correlational relationships.</p> <p>[Which procedure will help the students determine whether the relationship between electric current and changing magnetic field is causal rather than correlational?]</p>	<p>Key should explain <i>why</i> this procedure distinguishes the cause-and-effect relationship.</p>

Student Misconceptions:

*Response options can make use of Student Misconceptions (examples of scientifically incorrect assumptions) related to this performance expectation; references to misconceptions are listed in the links below:

- Energy is not transferred from one object to another unless those objects are in direct contact with each other.
- Energy can be transformed into a force.

From www.researchgate.net/publication/251302224 From [problem solving to a knowledge structure An example from the domain of electromagnetism](#)

- Students see electric and magnetic fields as having an unchanging nature.

From www.asee.org/public/conferences/8/papers/4051/download

- A charge in a magnetic field always experiences a force, even when stationary.
- Electric fields are the same as magnetic fields.

From onlinelibrary.wiley.com/doi/10.1002/sce.10119/pdf

- Students consider magnetic field lines to be real.
- Magnetic interaction occurs because of attraction and repulsion of the field lines.

Sample Cluster for PS.PS2.5:

Use the information to answer the following questions.

A student is riding their bike when their headlight turns off due to a dying battery. The student decides to find another way to power the headlight. The student researches alternative energy sources and finds a battery-free headlight powered by an electromagnet. The diagram shows the parts of the battery-free headlight.

Battery-Free Headlight

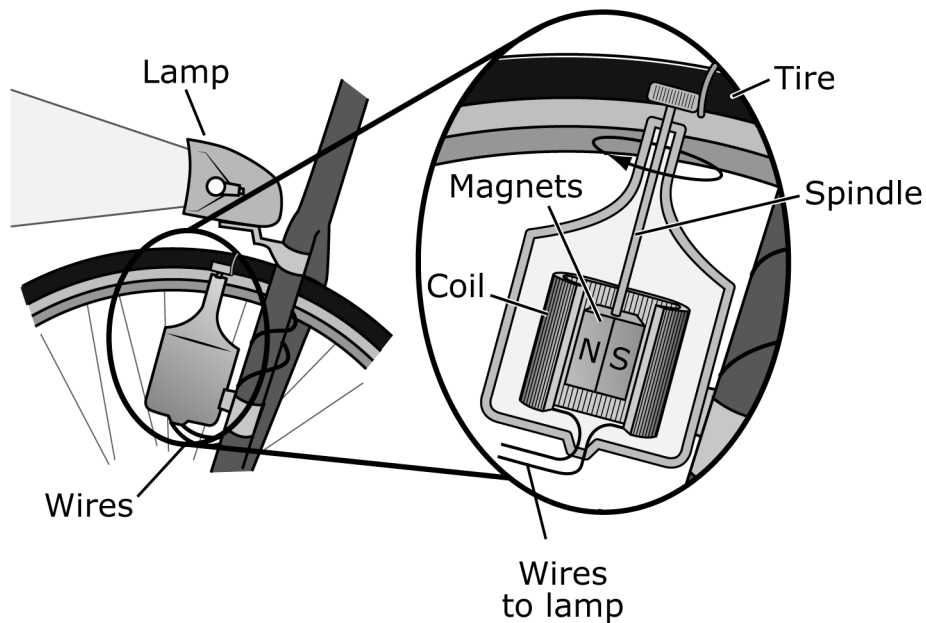

The student knows an electric current is produced when the tire spins the magnet. The electric current then travels through the wires to the headlight and provides the energy needed for the light bulb to turn on. The student wants to use the electromagnet as the new energy source for their headlight but wants to make the light brighter. They learn that the more current that flows through the bulb, the brighter the light will be. They decide to set up and conduct an investigation to determine how to produce more current from the electromagnet. The student investigates the effect of the magnetic strength of the magnet on the electric current. The diagram shows the student's experimental setup.

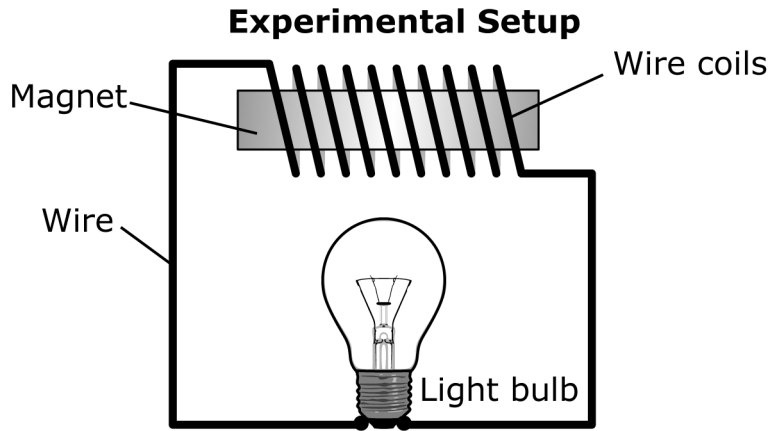

The student uses four magnets of different magnetic strengths. The magnetic strength of each magnet is measured in Tesla (T) and the electric current is measured in microamperes (μA). The graph shows the recorded data.

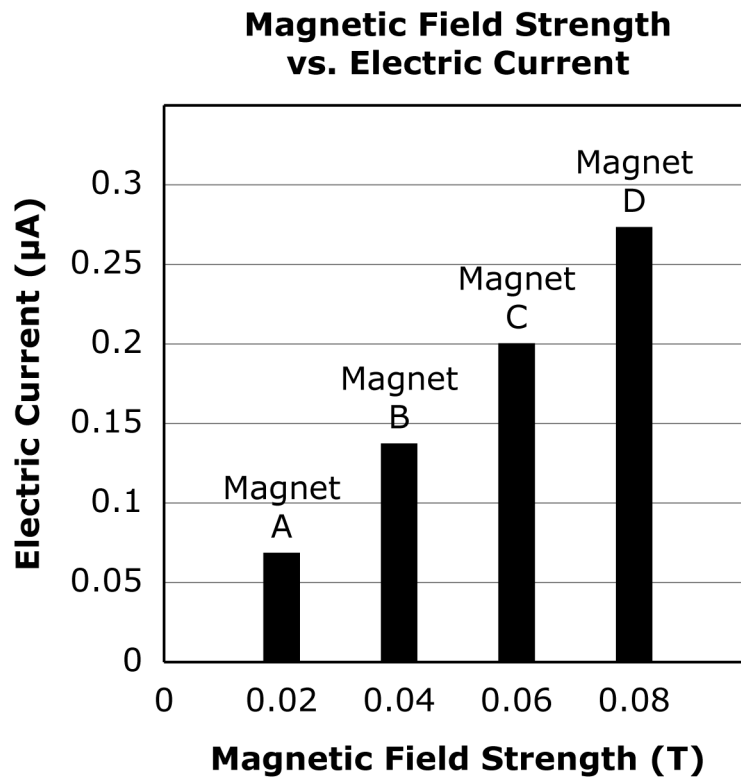

(Items on the following pages)

- 1** The student places the magnet in the wire coils as shown in the Experimental Setup diagram. The light does not come on. The student measures an electrical current of zero in the circuit but measures a magnetic field from the magnet.

How should the student modify the setup to measure an electric current?

- A** Change the magnetic field by using less wire.
- B** Change the magnetic field by adding another light bulb.
- C** Change the magnetic field by moving the magnet back and forth.
- D** Change the magnetic field by wrapping fewer coils around the magnet.

Standard: Plan and conduct an investigation to provide evidence that an electric current can cause a magnetic field and that a changing magnetic field can cause an electric current.

Cognitive Complexity:

SEP: Med

DCI: Med

CCC: Med

Overall Cognitive Complexity: Moderate Support

Distractor Rationale:

- A. Using less wire would lower the resistance but it is negligible.
- B. Adding another light bulb would not change the energy in the circuit.
- C. Correct. Moving the magnet back and forth creates a changing magnetic field which produces the electric field, which moves the electrical energy through the wire.**
- D. Making fewer turns in the wire coils would decrease the electrical current and it does not add energy to the circuit.

- 2** Based on the Battery-Free Headlight diagram and the Experimental Setup, which claim **best** describes how the magnet produces an electric current without a battery?
- A** The spinning magnet produces friction, which transfers static charge to the coil.
 - B** The spinning magnet produces heat energy, which is converted to the coil as electrical energy.
 - C** The spinning magnet produces a changing magnetic field, which causes an electric field in the coil.
 - D** The spinning magnet produces a changing magnetic field that attracts the coil, making it spin, which causes an electric field.

Standard: Plan and conduct an investigation to provide evidence that an electric current can cause a magnetic field and that a changing magnetic field can cause an electric current.

Cognitive Complexity:

SEP: Low

DCI: Med

CCC: Med

Overall Cognitive Complexity: Moderate Support

Distractor Rationale:

- A. The magnet does not touch the coil, so friction is not produced.
- B. The spinning magnet does not move fast enough to produce heat and there is no conversion method for the heat energy to electrical energy in the electromagnet.
- C. Correct. Electric current, which comes from the electric field, is only produced when the magnetic field is changing due to the spinning magnet.**
- D. The coil does not move even though the spinning magnet creates a magnetic field.

- 3** Which change to the investigation would **best** provide evidence that there is a direct relationship between the magnetic field and the electric current?
- A** Use a stronger magnet in the setup.
 - B** Remove the light bulb from the setup.
 - C** Increase the length of each trial in the experiment.
 - D** Measure the current on a different part of the circuit.

Standard: Plan and conduct an investigation to provide evidence that an electric current can cause a magnetic field and that a changing magnetic field can cause an electric current.

Cognitive Complexity:

SEP: Med

DCI: Med

CCC: Med

Overall Cognitive Complexity: Moderate Support

Distractor Rationale:

- A. Correct.** By doing this, students could determine how changing the strength of a magnet affects the electrical current that is produced.
- B.** Removing the light bulb takes away a location for the electric current to go but does not affect the amount of electric current.
- C.** The length of each trial does not affect the magnetic field strength or electric current.
- D.** Measuring the current on a different part of the circuit would not affect the magnetic field strength.

Energy: PS.PS3.1

back to “Item Specifications by Performance Expectation”

PS.PS3.1. Create a computational model to calculate the change in the energy of one component in a system when the change in energy of the other component(s) and energy flows in and out of the system are known.

OAS-S Clarification Statement:

Emphasis is on utilizing calculations to understand that energy is transferred in and out of systems and conserved, as well as explaining the meaning of mathematical expressions used in the model

OAS-S Assessment Boundary:

Assessment is limited to two or three components and the transfer of thermal energy, kinetic energy, potential energy, and/or the energies in gravitational, magnetic, or electric fields.

Science & Engineering Practice:

Using Mathematics and Computational Thinking

- Create a computational model of a phenomenon, process, or system based on basic assumptions.

Disciplinary Core Idea:

Definitions of Energy

- Energy is a quantitative property of a system that depends on the motion and interactions of matter and radiation within that system. That there is a single quantity called energy is due to the fact that a system’s total energy is conserved, even as, within the system, energy is continually transferred from one object to another and between its various possible forms.

Conservation of Energy and Energy Transfer

- Conservation of energy means that the total change of energy in any system is always equal to the total energy transferred into or out of the system.
- Energy cannot be created or destroyed, but it can be transported from one place to another and transferred between systems.
- Mathematical expressions, which quantify how the stored energy in a system depends on its configuration (e.g., relative positions of charged particles, compression of a spring) and how kinetic energy depends on mass and speed, allow the concept of conservation of energy to be used to predict and describe system behavior.
- The availability of energy limits what can occur in any system.

Crosscutting Concept:

Systems and System Models

- Models can be used to predict the behavior of a system, but these predictions have limited precision and reliability due to the assumptions and approximations inherent in models.

Energy: PS.PS3.1

In Lay Terms:

As the energy within a system changes form, energy is conserved but may flow in or out of the system. Students should be able to create computational models to describe energy of the parts of the system and energy flow and to support the idea that energy is conserved, while also helping to predict motion within the system.

Cluster Clarifications:

- Models must be simple (e.g., linear algebraic equations or data tables that can produce such equations).
- Engine cycles are beyond the scope of this assessment.
- Define energy in terms of joules.
- The relationship between kinetic energy and mass and speed is part of this assessment, but forces in general, including the relationship $F=ma$, is outside of the scope of this assessment.
- Avoid rotational energy.
- Focus is not on identifying energy types (e.g., thermal, gravitational, potential, kinetic, mechanical, light, sound, chemical) or energies in gravitational, electric or magnetic fields.
- The boundaries of the system must be defined in the stimulus.

Cluster Stimulus Attributes:

Typical stimulus elements:

- graphs, data tables, and text describing a model representing energy changes within a system
- pictorial depictions of objects in different stages of a process (time series)
- partial equations or computational models
- incorrect equations showing misconceptions or gaps in understanding

Possible contexts:

- roller coaster physics (safety of existing roller coasters)
- toy race car tracks
- air tracks/inclined planes
- cart with falling mass
- compression of a spring (pull back car, click-pen, mouse trap car, comeback can)
- pendulum
- simulations
- hurricanes, severe storms
- solar energy budget
- earthquakes
- car collision safety (bumpers/seat belts)
- efficiency of renewable forms of energy
- power plants: new plants are not steam run; direct heating of piston via gas or diesel fuel (e.g., city of Stillwater)
- tsunami
- heat packs/cold packs
- down jacket
- calorimetry to measure heat transfer
- heat lost by organism to environment as Calories burned
- boiling water in liquid nitrogen
- cell phone case dropping from height—focus on energy of impact; avoid force

Content and evidence to be included: data, descriptions, and/or partial models to support model creation/ completion and/or revision

Types of student responses that need to be supported: creating, completing, and/or improving/modifying models through the use of evidence in order to describe energy changes and conservation of energy within a system; describing what the models need to include in order to demonstrate flow of energy or conservation of energy

Allowable Item Types:

- MC
- TEI

Model Item Descriptions for PS.PS3.1:

#	Item Type	Model Stem (Items ask students to...)	Response Characteristics*
1	MC	Identify the best model to describe the given phenomenon. [Which computational model and explanation best fits the data from this experiment?]	Distractors may include models that show an incorrect or incomplete understanding of the phenomenon, process, or relationship.
2	MC	Identify what needs to be added to the model to complete it (and explain why). [Why is it important to have a reference level for potential energy in this system?] [Which of the following explains why initial energy should be added to this model?][Which of the following needs to be added to the computational model, and why?] [What happened to the energy (that is not accounted for in the model)?]	Distractors may include responses based on misconceptions.
3	MC	Complete or revise the model to demonstrate the underlying concept of conservation of energy. [What should be added to the model to demonstrate how energy changes within the system?] [Which change will allow this model to demonstrate conservation of energy?]	Distractors may include descriptions of changes that show an incorrect understanding of the underlying concept, or that do not correct or improve the model representation.
4	MC	Select the (best) model to describe/represent conservation of energy. [Which computational model (best) demonstrates the change in energy for component X?] [Which model correctly shows what happens to the energy within this system?]	Distractors may include computational models that are missing terms or contain additional terms.
5	TE	Complete a computational model for a system when given a data table describing the interaction of components within that system. [Based on the diagram and data table, drag and drop the components shown to complete the computational model.]	Drag-drop interaction. The system explored must show a change that can be modeled by the equation. The model should be in the form of a linear algebraic equation. Students should select from 5–6 draggers to complete 2 to 3 components of the model.
6	MC	Predict how results will change if characteristics of inputs to a model are changed. [How will the movement of the car change if the height of the loop is decreased to 0.25m?]	Distractors may include predictions that show a misunderstanding of the interactions of the components of the model. Exclude friction; Relationship to be explored is: increases in PE → increases in KE Do not include calculations to show $F=ma$

#	Item Type	Model Stem (Items ask students to...)	Response Characteristics*
7	MC	Identify relationships between inputs and outputs that need to be shown in the model being developed. [(cell phone in protective case, dropped from different heights) Which statement describes the relationship that should be shown between height and energy?]	Distractors may contain statements describing possible misconceptions related to inputs, outputs, and processes described in the model, or incorrect relationships.
8	MC	Identify relationships to be shown in a computational model. [How should the relationship between initial and final energy states be shown in the model?]	Distractors may include statements describing alternate relationships or misconceptions about functions/processes.
9	MC	Relate the relevance of a model to the quality or quantity of supporting evidence. [Which evidence from the data table would support the claim that the model is accurate?] [Based on the data in the table, which model is more relevant?] [Which set of data is more relevant to the model?]	Key may focus on aspects of the evidence that validate or provide greater accuracy to the model. Distractors may include data that relate to broader processes/relationships but do not support the claim or central concept.
10	MC	Relate the precision/reliability of a model to the approximations and assumptions made during its creation. [What evidence supports the students' claim that model X is less precise than model Y?] [What assumptions did students make when creating their model and how do these affect the precision of the model? (e.g., did not consider differences in amount of wind, which affects total energy of system)] [How would rounding off variable X to the tenths place affect the reliability of the model?]	Key may focus on aspects of the evidence that provide greater precision or reliability to the model. Distractors may include data that relate to broader processes/relationships but do not support the claim or central concept.
11	MC	Analyze data/diagrams to complete a computational model, expressed algebraically. [Based on the diagram/data, what additional factors should the students also consider as they build their computational model?]	Item requires student to analyze a diagram to complete the model (the diagram is complete; the model that the student is completing is not). Components of the diagram may include considering boundaries, a reference level for potential energy, initial energies of components, energy flows into and out of the system, final energies, etc.
12	MC	Use data describing initial and final energy states within a system and energy flow to create a computational model based on the principle of conservation of energy. [Based on the data in the table, which (computational) model best describes the behavior of the system?]	Distractors may incorporate data that is irrelevant to the model, or incomplete models.

#	Item Type	Model Stem (Items ask students to...)	Response Characteristics*
13	MC	Describe the limitations of the presented computational model in describing energy changes/energy flow. [What is one limitation of this computational model in describing energy flow?]	Distractors may include misconceptions about energy changes/energy flow.
14	MC	Use a computational model to calculate changes in energy for components of the system described by the model. [Based on the model, what is the maximum possible change in energy for the roller coaster car?]	Distractors may include calculations that ignore portions of the computational model, or which misidentify components of the system.

Student Misconceptions:

*Response options can make use of Student Misconceptions (examples of scientifically incorrect assumptions) related to this performance expectation; references to misconceptions are listed in the link below:

- One form of energy cannot be transformed into another form of energy (e.g., chemical energy cannot be converted to kinetic energy).
- Energy can be destroyed.
- Energy is associated mainly with human beings, not inanimate objects.
- The motion energy of an object does not depend on speed. (The motion energy of an object does not increase as the speed increases.)
- The motion energy of an object depends on the direction the object is traveling.
- The motion energy of an object depends on its shape.
- The gravitational potential energy of an object depends upon the path the object takes to get to the distance above the reference point.
- The gravitational potential energy of an object does not depend on the distance the object is above the ground.
- The gravitational potential energy of an object decreases as an object moves farther away from the center of the earth and the gravitational potential energy increases as the object falls toward the earth.
- An object has gravitational potential energy only at the edge of a cliff or table but not at some distance from the edge.
- The elastic energy of an object does not depend on how difficult it is to stretch or compress the object.
- Only objects that are stretched have elastic energy. Compressed objects do not have elastic energy.
- Elastic potential energy is the potential for an object to be stretched or compressed. For example, a rubber band has less elastic energy when it is stretched very far than when it is stretched a little bit because it can't be stretched much more, and a rubber band that is stretched a little bit has more elastic energy because it can be stretched a lot more.
- Springs or other elastic objects have the same amount of elastic energy regardless of how much they are stretched or compressed.
- Gravitational potential energy is the potential to fall; an object will lose all of its gravitational potential energy as soon as it starts to fall.
- Gravitational potential energy cannot be converted into thermal energy.
- Motion energy is not transformed into thermal energy, especially when there is no noticeable temperature increase.
- Motion energy cannot be transformed into gravitational potential energy.
- Gravitational potential energy cannot be transformed into motion energy.
- For a ball traveling over a frictionless hill, the steepness of the path is the most important factor affecting the ball's speed and motion energy.
- An object has energy within it that is used up as the object moves.
- For a ball traveling over a frictionless hill, the length of the path is the most important factor affecting the ball's speed and motion energy.
- An object always gains energy as it moves. For example, the height that a pendulum reaches after it is released is greater than its starting height because it gains energy as it swings.

Energy: PS.PS3.2

back to “Item Specifications by Performance Expectation”

PS.PS3.2. Develop and use models to illustrate that energy at the macroscopic scale can be accounted for as either motions of particles or energy stored in fields.

OAS-S Clarification Statement:

Examples of phenomena at the macroscopic scale could include the conversion of kinetic energy to thermal energy, the energy stored due to the position of an object above the earth (considered as stored in fields), and the energy stored between two electrically-charged plates. Examples of models could include diagrams, drawings, descriptions, and computer simulations.

OAS-S Assessment Boundary:

Assessment does not include quantitative calculations, chemical energy, or effects of air resistance/friction.

Science & Engineering Practice:

Developing and Using Models

- Develop, revise, and/or use a model based on evidence to illustrate and/or predict the relationships between systems or between components of a system.

Disciplinary Core Idea:

Definitions of Energy

- Energy is a quantitative property of a system that depends on the motion and interactions of matter and radiation within that system. That there is a single quantity called energy is due to the fact that a system’s total energy is conserved, even as, within the system, energy is continually transferred from one object to another and between its various possible forms.
- At the macroscopic scale, energy manifests itself in multiple ways, such as in motion, sound, light, and thermal energy.
- These relationships are better understood at the microscopic scale, at which all of the different manifestations of energy can be modeled as a combination of energy associated with the motion of particles and energy associated with the configuration (relative position of the particles). In some cases the relative position energy can be thought of as stored in fields (which mediate interactions between particles). This last concept includes radiation, a phenomenon in which energy stored in fields moves across space.

Crosscutting Concept:

Energy and Matter

- Energy cannot be created or destroyed—only moves between one place and another place, between objects and/or fields, or between systems.

In Lay Terms:

Energy is always changing from one form to another, but the total energy is conserved. Students should be able to develop and use models to describe the different forms of energy at the microscopic scale as either energy associated with the motion of particles or energy associated with relative position of particles. When considering energy related to relative position, energy can be thought of as stored in fields.

Energy: PS.PS3.2

Cluster Clarifications:

- The boundaries of the system must be defined in the stimulus.
- Define energy in terms of joules.
- The relationship between kinetic energy and mass and speed is part of this assessment, but forces in general, including the relationship $F=ma$, is outside of the scope of this assessment.
- Focus is not on identifying energy types (thermal, gravitational, potential, kinetic, mechanical, light, sound).
- Chemical energy is outside of the scope of this assessment.
- Exclude effects of air resistance/friction.

Cluster Stimulus Attributes:

Typical stimulus elements:

- text descriptions of observations and phenomena for conversions of energy
- partial or complete diagrams showing energy conversions
- experimental data

Possible contexts:

- capacitors (Taser, electromagnetic can crusher)
- object changing in elevation or position (vertically)
- model rocket launch
- collision between a ball and a bat
- heating curve
- intensity of sound
- phase changes—particle slowdown near absolute zero
- sound levitation
- 3D Rubens' tubes
- acoustic weapons (aka loud concerts)
- light intensity (related to solar eclipse; use lumens as unit)
- magnetic braking (limit to energy in field, not force applied)
- cathode ray tube
- electron microscope
- scanning EM (not scanning tunneling)
- EM radiation
- defibrillator

Content and evidence to be included: descriptions and diagrams/pictures of phenomena involving energy conversions and/or models of energy conversions; tables and graphs of data

Types of student responses that need to be supported: creating, completing, and/or improving models that describe energy conversions (and conservation of energy during these conversions); describing and interpreting energy conversions and conservation of energy using these models; predicting behavior using these models

Allowable Item Types:

- MC
- TEI

Model Item Descriptions for PS.PS3.2:

#	Item Type	Model Stem (Items ask students to...)	Response Characteristics*
1	MC	Identify the model that shows the correct labeling of a system undergoing energy transformations.	Distractors may include models with incorrect organization/labeling.
2	MC	Describe the components and/or system that are shown/need to be shown by the model. [What is the system shown by this model?] [What are some of the components that should be included in this model?]	Distractors may contain misinterpretations of the model and its components, particularly tied to misconceptions.
3	MC	Describe the purpose of the model. [Which statement best describes how this model is important to understanding how energy is converted when water condenses on the outside of a cool glass?]	Distractors may contain misinterpretations of the purpose of the model, particularly tied to misconceptions.
4	MC	Identify evidence that supports the model. [Which evidence supports this model?]	Distractors may include evidence that is irrelevant or which can serve to reject the model.
5	MC	Complete the model to demonstrate the underlying concepts of conversion and/or conservation of energy. OR Identify a missing component of the model or something that should be added to the model. [What should be added to the model to account for all of the energy?] [Which component should be added to the model to demonstrate the conservation of energy?]	Distractors may include additions that do not account for the conversions/transfer of energy in the system.
6	MC	Revise the model to demonstrate the underlying concept about conversion of energy and/or conservation of energy. [Which change will allow this model to demonstrate conservation of energy?]	Distractors may include changes that fail to account for conservation of energy, changes based on other misconceptions, or changes that do not correct or improve the model.
7	MC	Analyze the model to identify the impact of change in an independent variable on energy conversions and conservation of energy. [Which statement best describes how an increase in the height of the hill will affect PE, KE, and total energy in the system?]	The mass of the object being moved must be discounted. Friction/air resistance must be discounted. Focus is conceptual (PE→KE), not calculations. Object should be moving straight up/down.

#	Item Type	Model Stem (Items ask students to...)	Response Characteristics*
8	MC	Describe the interactions among components of the model related to conversion or conservation of energy. [Based on the model, how is the amount of PE at point X related to the amount of KE at point X?] [How is the change in kinetic energy of the particles shown from times x to y related to conservation of energy?]	Distractors may include misinterpretations/misconceptions about the relationships in the model and conversions/conservation of energy.
9	MC	Identify the key process shown in the model. [In which locations in the model is PE increasing?]	Distractors may include locations/steps not related to the key process shown in the model.
10	MC	Describe the interactions among components of the model related to energy conversion or conservation. [Based on the information shown in the model, how is KE related to PE?]	Items should focus on particle changes. Key may focus on energy or conversions. Distractors may include descriptions of roles not related to the specified process/function or interactions that occur but are not involved directly in the process.
11	MC	Identify the best model to describe a related phenomenon involving energy conversions or conservation of energy, based on the initial model. [Based on the students' model, which model demonstrates how energy conversions differ for a pendulum released at twice the original height?]	Distractors may include models that show a misunderstanding/misconception of the relationship portrayed in the model.
12	MC	Select and explain the model that best fits a set of observations or data illustrating energy conversions/conservation of energy. [Which model best describes the data shown in the table?]	Distractors may include models that do not represent or incorrectly represent energy conversions/conservation of energy.
13	MC	Explain how data support a particular model of energy conversions or conservation of energy. [Which statement describes how the data collected in this investigation support the model?]	Distractors may include statements related to data that do not support the model or model components unrelated to the data.
14	MC	Explain how a (given) model supports or fits observations/experimental results, or vice versa. [Which explanation for the results of the students' experiment is best supported by the model, and why?] [How does the data shown in the table provide evidence for the model the students created?]	Explanatory statements may include inputs/outputs or component comparisons and reasoning based on energy transformation(s). Distractors may include plausible explanations that do not directly provide evidence for the results obtained.

#	Item Type	Model Stem (Items ask students to...)	Response Characteristics*
15	MC	Relate a model to supporting evidence. [Which evidence from the data table would support the claim that the model is accurate?]	Key may focus on energy evidence or component evidence that supports energy transformations. Distractors may include data that relate to broader relationships but do not support the claim of accuracy.
16	TE	Create/complete a model to show the conversion of energy within a system. [Complete the model showing conversion of energy as a pendulum moves within its path.] [Complete the model to compare the total energy for a BASE jumper at different positions.]	Drag-drop interaction. A minimum of three and maximum of four correct associations should be used. Distractor choices may be incorrect associations that include characteristics that do not apply to the phenomenon described. Correct responses show all labels placed appropriately. Partial credit would be given for a subset of correct labels.
17	MC	Use a model to make predictions about a phenomenon. [Based on the graph, how would the kinetic energy of the water change at 15 minutes if twice as much water was heated?]	Distractors may include predictions that misinterpret components of the model.
18	MC	Use the model to describe the energy flows between the system and its surroundings.	Possible contexts for this model stem include absolute zero, condensation, or melting.
19	MC	Explain how the model works at both the macroscopic and molecular/atomic levels.	Key should focus on how changes at the molecular/atomic level account for observations at the macroscopic level.
20	MC	Use the model to explain how changes in the relative position of objects in fields can affect the energy of the field. [How will the movement of the charged particles away from each other affect the field energy?]	Possible contexts for this model stem include cathode ray tube and changing electron direction.
21	MC	Use the model to explain how increases in one form of energy affect other forms of energy. [How will an increase in thermal energy shown at location X affect the amount of gravitational potential energy shown at location Y?]	Distractors may include explanations that incorporate misconceptions related to transformations of energy.

Student Misconceptions:

*Response options can make use of Student Misconceptions (examples of scientifically incorrect assumptions) related to this performance expectation; references to misconceptions are listed in the link below:

- One form of energy cannot be transformed into another form of energy.
- Energy can be destroyed.
- Energy can be created.
- Gravitational potential energy is the potential to fall; an object will lose all of its gravitational potential energy as soon as it starts to fall.
- Gravitational potential energy cannot be converted into thermal energy.
- Motion energy is not transformed into thermal energy, especially when there is no noticeable temperature increase.
- An object has energy within it that is used up as the object moves.
- Energy is associated mainly with human beings, not inanimate objects.
- Thermal energy is not related to the kinetic energy of the molecules that make up an object.
- Motion energy cannot be transformed into gravitational potential energy.
- Gravitational potential energy cannot be transformed into motion energy.
- An object always gains energy as it moves. For example, the height that a pendulum reaches after it is released is greater than its starting height because it gains energy as it swings.

Energy: PS.PS3.3*

back to “Item Specifications by Performance Expectation”

PS.PS3.3. Design, build, and refine a device that works within given constraints to convert one form of energy into another form of energy.*

OAS-S Clarification Statement:

Emphasis is on both qualitative and quantitative evaluations of devices. Examples of devices could include Rube Goldberg devices, wind turbines, solar cells, solar ovens, and generators. Examples of constraints placed on a device could include the cost of materials, types of materials available, having to use renewable energy, an efficiency threshold, and time to build and/or operate the device.

OAS-S Assessment Boundary:

Assessment for quantitative evaluations is limited to total output for a given input. Assessment is limited to devices constructed with materials provided to students.

Science & Engineering Practice:

Designing Solutions

- Design, evaluate, and/or refine a solution to a complex real-world problem, based on scientific knowledge, student-generated sources of evidence, prioritized criteria, and tradeoff considerations.

Disciplinary Core Idea:

Definitions of Energy

- At the macroscopic scale, energy manifests itself in multiple ways, such as in motion, sound, light, and thermal energy.

Defining and Delimiting Engineering Problems

- Criteria and constraints also include satisfying any requirements set by society, such as taking issues of risk mitigation into account, and they should be quantified to the extent possible and stated in such a way that one can tell if a given design meets them.

Interdependence of Science, Engineering, and Technology

- Modern civilization depends on major technological systems. Engineers continuously modify these technological systems by applying scientific knowledge and engineering design practices to increase benefits while decreasing costs and risks.

Crosscutting Concept:

Energy and Matter

- Changes of energy and matter in a system can be described in terms of energy and matter flows into, out of, and within that system.

*The performance expectations marked with an asterisk integrate traditional science content with engineering through a Practice or Disciplinary Core Idea.

In Lay Terms:

Students should be able to create and build machines that demonstrate the following:

- Energy can be seen in multiple ways and be used to accomplish goals by building machines that capture and use that energy.
- These machines can convert one form of energy to another form.
- Because energy cannot be created or destroyed, the total energy is conserved, as energy flows into, out of, and within systems.

**associated sample cluster included*

Energy: PS.PS3.3*

Cluster Clarifications:

- The boundaries of the system must be defined in the stimulus.
- Criteria and constraints should be a part of the initial design presented to the student, but may or may not be identified as such.
- Designs should be presented within the context of the engineering design cycle.
- Do not use brand names of commercially available devices.
- Devices should have real-life applications that are relevant or accessible to high-school students.
- Carefully consider cultural bias when selecting devices, providing background information as necessary.
- Devices should be buildable within the high school classroom or via simple simulations.
- Stimuli and items should use familiar units (e.g., Calories, watts, joules, degrees C)
- Students should not be required to make unit conversions to determine inputs and outputs.

Cluster Stimulus Attributes:

Typical stimulus elements:

- data tables
- diagrams, pictures, models, or text descriptions of devices
- diagrams or text descriptions of mechanisms/explanations

Possible contexts:

- Rube Goldberg devices
- gravity light
- solar ovens
- photovoltaic cells
- hydroelectric generator
- wind turbine
- coal (or other organic fuel) power plant
- solar water heater
- doorbell circuit
- microphone circuit
- piezoelectric generator
- water mill
- compound pulley systems (in a novel context)
- handheld centrifuge
- camping stove electronics charger
- solar tiles on roadways
- solar windows
- solar spray paint
- underwater turbines
- pumps

Content and evidence to be included: comparisons of multiple designs and diagrams showing components of design; data tables comparing properties of materials to be incorporated into design; data tables showing preliminary test results, tradeoffs, return on investment

Types of student responses that need to be supported: predicting the result of changing a variable; evaluating a design; modifying a design; making qualitative comparisons of efficiency and benefit/risk analysis and/or mitigation; prioritization of criteria; simple quantitative calculations of total output for a given input

Allowable Item Types:

- MC
- TEI

Model Item Descriptions for PS.PS3.3:

#	Item Type	Model Stem (Items ask students to...)	Response Characteristics*
1	MC	<p>Describe how to modify/change a design to meet a particular design criterion or constraint.</p> <p>[How can this device be refined to decrease cost/meet cost requirement/other constraint?]</p> <p>[How should the students change their design to meet the requirements of this device?]</p> <p>[Based on the data in the table, which change to the design will increase how quickly the device converts electrical energy to sound energy? (distractors must all show electrical to sound conversion)]</p> <p>[Based on the students' results, which combination of materials would be most useful to meet the requirements of this device?]</p> <p>[Based on the data in the table, which change should the student make to increase the efficiency of the device?]</p>	<p>Distractors may include modifications/changes that are irrelevant to a design criterion or which exceed or fail to meet the constraint.</p>
2	MC	<p>Evaluate the usefulness of a design.</p> <p>[(Bike charging device that can charge a cell phone in 5 hours) Is this device useful, taking into account the required input and the resulting output?]</p>	<p>Key may require students to evaluate quantitatively. However, all outputs should use the same units as inputs and require no unit conversions.</p>
3	MC	<p>Evaluate different designs to determine which would be the best for a particular goal, or how to incorporate specific strengths of each into a new design.</p> <p>[How should the student combine these designs to best meet the constraints of the project?]</p> <p>[How should the student combine these designs to best meet (a particular requirement) of the project?]</p> <p>[How should the student combine these designs to improve efficiency?]</p> <p>[Which aspect of model 1 or 2 best meets criterion X and why?]</p> <p>[Which design would (best) demonstrate the transformation of mechanical to electrical energy? (electricity)?]</p>	<p>Distractors may include designs that do not achieve a particular goal or which incorporate features that are less effective at meeting the goal.</p>

#	Item Type	Model Stem (Items ask students to...)	Response Characteristics*
4	MC	<p>Predict results of a specific action or change based on the use of or modifications to a device.</p> <p>[(Table of thermal conductivities of different metals.) How will changing from aluminum to copper tubing affect the amount of solar energy absorbed by the system?]</p> <p>[How will insulating the water tank affect the results of this experiment?]</p> <p>[How will painting the inside of the solar collector white affect the results of this experiment?]</p> <p>[Which graph shows the temperature changes that are likely to result if the insulation surrounding the water tank is increased to 2 cm?]</p>	<p>Item and options may be qualitative or quantitative in nature.</p> <p>Distractors may include predictions that contradict results obtained from previous modifications.</p>
5	MC/TE	<p>Evaluate and/or compare the efficiency of one or more energy transformation devices.</p> <p>[Based on the data, which device is most efficient?]</p> <p>[Which characteristics of this device make it more energy efficient than the earlier device created by the team?]</p> <p>[Which evidence supports the conclusion that device X is most efficient at transforming kinetic energy into electricity?]</p> <p>[Based on the data table showing current output, how does the angle between the reflector and the solar panel affect efficiency?]</p> <p>[The table shows the amount of solar energy absorbed by the devices in kJ. Based on the designs for each device, drag and drop the most likely reasons for the differences in efficiency seen in each device.]</p> <p>[What does the pattern of data allow you to conclude about efficiency of this/each device?]</p>	<p>Distractors may include irrelevant characteristics of the device, irrelevant evidence, or incorrect conclusions.</p> <p>TEI: Drag-drop or matching interaction.</p>
6	MC	<p>Identify the constraints for a given system, which may include amount and cost of materials, safety, and time of functioning.</p> <p>[What are the constraints in this system?]</p> <p>[What are safety constraints in this system?]</p> <p>[Which constraints did the students build into this design?]</p> <p>[(Context of power plant) Which environmental constraints did the students consider in developing this plan?]</p>	<p>Distractors may include constraints not built into the design or characteristics that are not identified in the stimulus as constraints.</p>

#	Item Type	Model Stem (Items ask students to...)	Response Characteristics*
7	MC	Evaluate criteria and constraints for a given system, which may include amount and cost of materials, safety, and time of functioning. [How well does this design meet the criteria and constraints of the project?] [(Data describing lithium batteries' efficiency rate, catastrophic failure rate, and constraint of meeting safety requirements) Which battery will be the best to choose based on the priorities listed?]	Distractors may include conclusions that are based on misprioritization of criteria and constraints, or of prioritization characteristics that are not identified in the stimulus as constraints.
8	TE	Calculate the output efficiency of a given device or devices. [Complete the table to show how efficiency of the solar cell changed as the angle of the solar cell was varied.]	Matching interaction. Key will match tilt to efficiency.
9	TE	Rank modification to an existing device based on increasing efficiency.	Drag-drop interaction. Four modifications should be required for ranking.
10	TE	Using the existing device, choose the modifications that will increase efficiency.	Drag-drop interaction. 6 draggers to manipulate: 4 increase, 2 decrease or remain the same.
11	MC	Identify and/or describe the relationships among the parts and/or processes within a system. [Which part of the energy system does this model show?] [At which point does the energy conversion occur?] [What would happen if you increased component X?]	Distractors may describe relationships not seen within the system.
12	MC	Revise a model, based on new evidence. [How should this model(s) be revised in light of the new evidence?]	Key may focus on a revision that adds clarity to the model. Distractors may include revisions that detract from or reduce the value of the given model or revisions that add information but do not add value to the model.
13	MC	Analyze a system to determine the cause of its failure or inefficiency. [Based on your data what appears to be the cause of the system failure/low efficiency?]	Distractors may include evidence that is irrelevant or which would improve the efficiency of the system.

Student Misconceptions:

*Response options can make use of Student Misconceptions (examples of scientifically incorrect assumptions) related to this performance expectation; references to misconceptions are listed in the links below:

- One form of energy cannot be transformed into another form of energy.
- Energy can be created.
- Gravitational potential energy cannot be transformed into motion energy.

From edtechdev.wordpress.com/2010/01/02/misconceptions-about-design

- Engineering is a linear process, not one that moves in iterative cycles that revisit past decisions and consider alternate strategies/design pathways.
- Engineering is only about coming up with ideas, not implementing them.
- Engineers can ignore design constraints to come up with the best design regardless of cost or other factors.
- The first solution to a problem is the best solution.

Sample Cluster for PS.PS3.3:

Use the information to answer the following questions.

Students in a science class were asked to build a device that would convert one form of energy into another form. The students were given the following design criteria:

- device must charge a battery to run a six-watt cell phone for seven hours (forty-two watt hours [Wh])
- device must be portable
- device must be built from recycled materials

One group of students designed a bike-powered charging station. They learned that a motor run in reverse can work as an electrical generator. They built their generator by attaching a roller skate wheel to an old scooter motor. The generator was mounted to a wooden board, as shown in the first diagram.

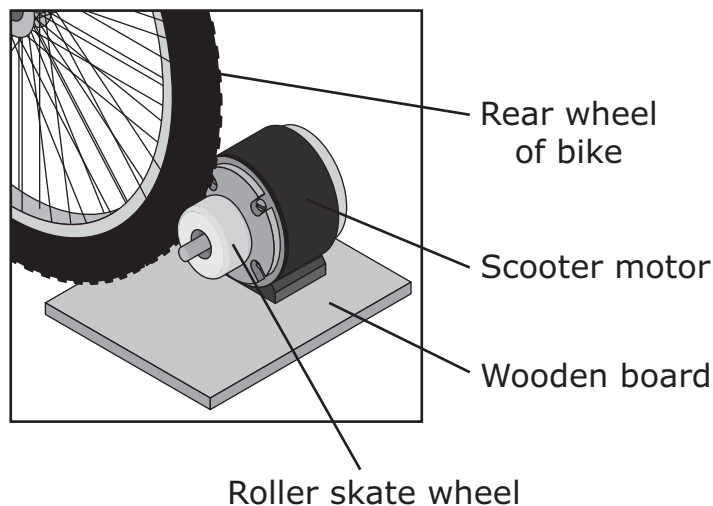

The generator was placed behind the rear wheel of the bike with the roller skate wheel touching the bike wheel. When the bike wheel spun it caused the roller skate wheel to rotate, spinning the generator and producing electricity. Next, the students built a wooden stand to hold the bike upright. Then the students attached the generator to a rechargeable twelve-volt battery.

The second diagram shows the completed setup.

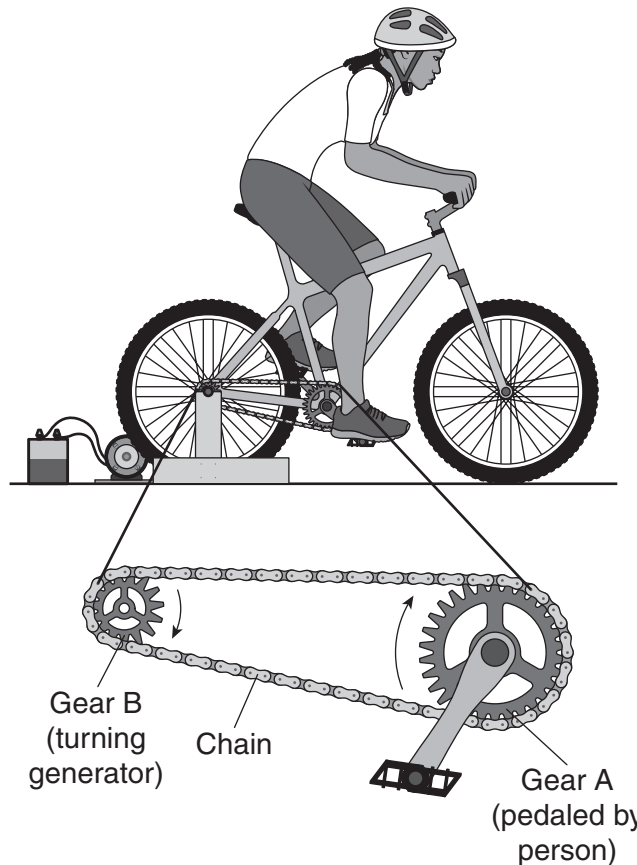

A person pedaled to turn Gear A, which caused the chain attached to the gear to move. This, in turn, caused Gear B and the back wheel to spin, producing electricity and charging the battery. The students noticed that Gears A and B turned at different rates. The students learned this difference in rate is called gear ratio. The third diagram shows how gear size affects gear ratio. Gear speed is measured in rpm (revolutions per minute).

Gear Ratio

Ratio 1 to 1

Ratio 2 to 1

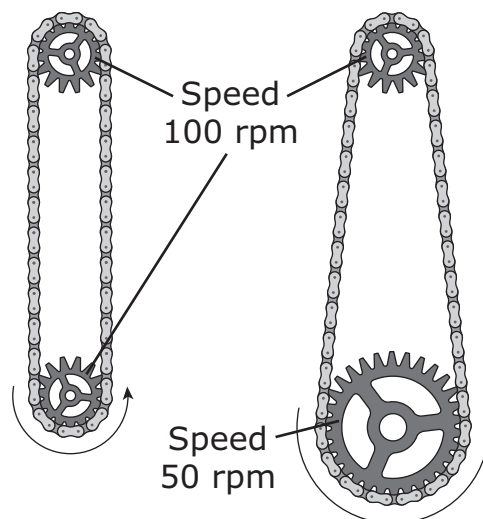

The data table shows speed data the students recorded for four people using the bike generator.

Speed Testing

3-minute Test				
	Gear Speed (rpm)			
Person	Gear A	Gear B	Charging Power (W)	Stored Energy (Wh)
W	103	323	129.1	6.46
X	105	330	151	7.55
30-minute Test				
Y	102	315	105	52.5
Z	101	316	106	53

The students also learned that not all of the energy put into the battery would be available to charge the cell phone. In general, only about 70% of the energy stored in a battery can be used to charge a device.

(Items on the following pages)

1 Which statement best describes an energy conversion in this system?

- A** Mechanical energy is converted to potential energy between Gear A and the chain.
- B** Kinetic energy is converted to potential energy between the rear wheel and Gear B.
- C** Potential energy is converted to chemical energy between the generator and the battery.
- D** Mechanical energy is converted to thermal energy between the rear wheel and the generator.

Standard: Design, build, and refine a device that works within given constraints to convert one form of energy into another form of energy.

Cognitive Complexity:

SEP: Low

DCI: Med

CCC: Med

Overall Cognitive Complexity: Moderate Support

Distractor Rationale:

- A. The student may think that the moving chain is potential energy.
- B. The student may think that the moving wheel is potential energy.
- C. The student may think that the moving generator is potential energy.
- D. Correct. As the rear wheel rubs on the generator, causing it to spin, one form of mechanical energy is converted to thermal energy due to friction.**

2 Based on the input and output data shown in the table, is the design useful?

- A** Yes, because 3 minutes of pedaling will produce an average of 140 W of power, and 98 W will be available to charge the phone.
- B** No, because 30 minutes of pedaling will produce an average of 52.8 Wh of power, and 37 Wh will be available to charge the phone.
- C** Yes, because 30 minutes of pedaling will produce an average of 105.5 W of power, and 42 W are needed to run the cell phone for 7 hours.
- D** No, because 3 minutes of pedaling will produce an average of 7.01 Wh of power, and 42 Wh are needed to run the cell phone for 7 hours.

Standard: Design, build, and refine a device that works within given constraints to convert one form of energy into another form of energy.

Cognitive Complexity:

SEP: Med

DCI: Med

CCC: High

Overall Cognitive Complexity: Low Support

Distractor Rationale:

- A. The student may not understand that they should consider watt-hours.
- B. Correct. Although sufficient watt-hours are produced, not all energy stored in the battery can be put to use.**
- C. The student may not understand that they should consider watt-hours.
- D. The student may not understand that they should also look at the 30-minute test data.

3 Which change will decrease the amount of time it takes to transfer energy to the battery, assuming the cyclist continues pedaling at approximately 100 rpm?

- A** replace Gears A and B with two larger gears
- B** replace Gears A and B with two smaller gears
- C** replace Gear A with a larger gear and Gear B with a smaller gear
- D** replace Gear A with a smaller gear and Gear B with a larger gear

Standard: Design, build, and refine a device that works within given constraints to convert one form of energy into another form of energy.

Cognitive Complexity:

SEP: High

DCI: High

CCC: High

Overall Cognitive Complexity: Low Support

Distractor Rationale:

- A. The student may not understand that the ratio between the gear sizes is the variable needed to be changed.
- B. The student may not understand that the ratio between the gear sizes is the variable needed to be changed.
- C. Correct. In this scenario the gear ratio increases, and the rpm for gear B increases decreasing the amount of time needed to charge the battery.**
- D. The student may not understand that in this scenario, the gear ratio decreases because gear B is increasing in size, and the rpm for gear B decreases. This increases the amount of time needed to charge the battery.

Energy: PS.PS3.4

back to “Item Specifications by Performance Expectation”

PS.PS3.4. Plan and conduct an investigation to provide evidence that the transfer of thermal energy when two components of different temperature are combined within a closed system results in a more uniform energy distribution among the components in the system (second law of thermodynamics).

OAS-S Clarification Statement:

Emphasis is on analyzing data from student investigations and using mathematical thinking to describe the thermal energy changes both quantitatively and conceptually. Examples of investigations could include mixing liquids at different initial temperatures or adding objects at different temperatures to water.

OAS-S Assessment Boundary:

Assessment is limited to devices constructed with materials provided to students. Assessment includes both quantitative and conceptual descriptions of energy change.

Science & Engineering Practice:

Planning and Carrying Out Investigations

- Plan an investigation or test a design individually and collaboratively to produce data to serve as the basis for evidence as part of building and revising models, supporting explanations for phenomena, or testing solutions to problems. Consider possible confounding variables or effects and evaluate the investigation’s design to ensure variables are controlled.

Disciplinary Core Idea:

Conservation of Energy and Energy Transfer

- Energy cannot be created or destroyed, but it can be transported from one place to another and transferred between systems.
- Uncontrolled systems always evolve toward more stable states—that is, toward more uniform energy distribution (e.g., water flows downhill, objects hotter than their surrounding environment cool down).

Crosscutting Concept:

Systems and System Models

- When investigating or describing a system, the boundaries and initial conditions of the system need to be defined and their inputs and outputs analyzed and described using models.

In Lay Terms:

Student should be able to describe how to carry out an investigation that helps demonstrate:

- Students should be able to carry out an investigation and collect data that will help demonstrate that thermal energy will distribute throughout a system until a balance is reached.

Cluster Clarifications:

- Note that the focus of this PE is not naming and labeling variables; however a maximum of one item per cluster may address the idea of controlling variables. Items should not address the idea of control groups.
- Descriptions of relationships between variables should not use the traditional if/then hypothesis format.
- Context may include multiple investigations, each addressing a different variable, but any data tables should be shown separately to make it clear that only one variable is to be changed per investigation.
- Use degrees Celsius or Kelvin, depending on context.
- Stimulus/items should focus on energy transfer and keeping track of energy, not heat transfer. Likewise, stimulus/items should focus the reliability of measurements, not efficiency calculations.
- Engine cycles are beyond the scope of this assessment.
- Simple steam engine, presented conceptually, are within the scope of this assessment.
- Stimuli should not discuss tornadoes, due to sensitivity issues.

Energy: PS.PS3.4

Cluster Stimulus Attributes:

Typical stimulus elements:

- initial observation, question or claim to be investigated
- diagrams and/or text-based descriptions of investigation design
- (partial) data tables
- experimental data
- theoretical data
- system models

Possible contexts:

- adding cold water to hot bath
- adding ice to a hot beverage
- using stone blocks to cool a room temperature beverage
- soil temperature change in freezer
- warm air and water (swamp cooler)
- “density cubes”
- thermal pollution
- lake inversion
- sea ice melting
- temperature inversions in ponds
- uneven heating of earth, cold water from poles, prevailing winds
- fireplace
- urban heat island
- storms
- Native American cooking stones
- pizza stones/brick ovens
- immersion bath (*sous vide*)
- pho
- lake heating in summer
- lake-effect snow
- offshore breezes
- electromagnetic background radiation and distribution in universe
- heat death of universe
- pressure cooker
- cubed versus crushed ice
- mantle convection
- double-walled insulated cups with vacuum seal
- thermal windows (argon gas)

Content and evidence to be included: diagram and experimental data, pictures, data tables, written explanations and descriptions, graphs, transitional diagrams (time series)

Types of student responses that need to be supported: evaluation of experimental design, refining experimental design, using data as evidence to justify designs, examining accuracy/reliability of data, limitations of data or design or system, controlling variables; boundaries/conditions, inputs and outputs of system

Allowable Item Types:

- MC
- TEI

Model Item Descriptions for PS.PS3.4:

#	Item Type	Model Stem (Items ask students to...)	Response Characteristics*
1	MC	Predict how a given modification (e.g., change in proportion of hot and cold water) will affect temperature of thermal equilibrium. [How will increasing the percentage of hot water to 70% affect the temperature of the system when it reaches equilibrium?]	Distractors may incorrect predictions of the amount of time, temperature or other component of system. Possible contexts for this model stem include: immersion cooker and circulation pump, and effect on system.
2	MC	Predict how a given modification will affect the thermal equilibrium within a closed system. [Which graph shows how increasing the size of the metal cylinder will most likely affect the temperature when the system reaches thermal equilibrium?] [Which material would give results most similar to the graph for the insulator, wood?]	Distractors may include incorrect assumption that modification will stop transfer of thermal energy. Possible contexts for this model stem include: counter current circulation
3	TE	Define the inputs, outputs and boundaries of the system being investigated. Which model defines the inputs, outputs and boundaries of this system? [Drag and drop the labels to define the inputs, outputs and boundaries of this system.]	Drag-drop or drop-down interaction. Possible contexts for this model stem include: the universe, traditional versus tankless hot water heater, top and bottom of traditional hot water heater versus heater with circulation pump
4	MC	Calculate the change in thermal energy for a system with components of identical mass/ volume and composition. [Which expression shows how the students should calculate the change in thermal energy in their system?]	
5	MC	Describe/Explain the change in thermal energy for a system with components of identical mass but different composition.	A table must be provided, including information about specific heat.
6	TEI	Describe how to build a closed system required by the experimental design, describing the boundaries of the system, limitations, and the initial conditions of the system [Complete the sentence to describe how to complete the system, selecting the boundaries of the system and the initial conditions of the system.]	Drop-down interaction. Include menus placed strategically on labels of the diagram of the system undergoing thermal transfer, such that at each point students decide one of the two data dimensions (i.e., boundaries, initial conditions). Menus should contain one example of each data dimension (only one correct dimension) plus 1–3 extraneous dimensions. Correct responses will show all selections correctly. Partial credit would be given for a subset of correct responses.
7	MC/ TE	Identify possible ways that energy is escaping from the system. [Click on the parts of the system where energy is likely to escape the system]	Hot-spot interaction.

#	Item Type	Model Stem (Items ask students to...)	Response Characteristics*
8	MC	Adjust experimental design to account for apparent loss of energy from the system.	Distractors may include adjustments that do not alter the amount of energy loss from the system or which increase the energy loss from the system.
9	MC	Describe the direction of thermal energy transfer between the components within a system.	Distractors may include descriptions that show misconceptions about energy transfer within a system.
10	MC	Predict data/results of an investigation about thermal energy transfer. [Which result of the investigation would support the hypothesis that an increase in the mass of the X will result in a change in thermal equilibrium?]	Key may focus on processes/mechanisms involved in thermal energy transfer and what data/variables should be observed or measured to evaluate/analyze the process or mechanism. Distractors may include misunderstandings of thermal energy transfer or of the data necessary to support a prediction about energy transfer.
11	MC	Identify the hypothesis of an investigation about transfer of thermal energy. [Which question/hypothesis is being investigated in this procedure?]	Key may focus on the dependent variable's response to the intended change in the independent variable. Distractors may include variables or questions/predictions that do not connect the relevant cause-effect pattern.
12	MC	Critique an investigation for inaccuracies, limitations, or flaws in procedures, or expected results considering the question or claim. [Which statement best explains why the data from the table may not be reliable to answer the question/claim being investigated?]	Items should incorporate elements of content misconceptions in addition to consideration of varying degrees of impact of the investigative shortcomings on the results. Distractors may include steps/procedures that do not significantly affect results or conclusions.
13	MC	Describe the data/observations that would support the purpose of a question or claim being investigated. [Which of the following observations would provide evidence that thermal energy transfer decreases predictably over time?]	Distractors may include descriptions of related claims that cannot be investigated (or may be only partially investigated) with the data or observations supplied.
14	MC	Explain how to measure relevant properties of the parameter(s) being investigated. [What components of the system should students monitor to confirm that energy transfer is occurring?]	Distractors may include incorrect procedures.
15	MC	Explain how to manipulate or analyze measurements to be collected in an investigation. [What would be the best data to collect to ensure that the data is reliable?]	Distractors may include manipulations of inappropriate factors, inappropriate calculations or relationships, incorrect selection of measurement criterion, or inappropriate limits of acceptable accuracy/reliability.

#	Item Type	Model Stem (Items ask students to...)	Response Characteristics*
16	MC	Describe the investigation plan that will provide the most useful evidence to answer a given question or support/reject a claim related to thermal energy transfer. [Which investigation plan should the students use to demonstrate the idea that thermal energy transfer depends on both the mass of object and the amount of thermal energy each object contains?]	Distractors may include irrelevant steps or process that will be less useful in providing data to answer the question or support/reject the claim.
17	MC	Modify an investigation plan (e.g., to improve quality of data) to produce data to support a given claim related to changes in a system undergoing thermal energy transfer. [Which of the following shows how to modify the investigation/plan/procedure to test whether the type of material used affects thermal energy transfer?] [How should the students modify their investigation to support the accuracy of their conclusion about the effect of differences in initial temperature between the two liquids?]	Distractors may include modifications that will make the data less useful in supporting the claim or will add procedures irrelevant to supporting the claim. This may include increasing the number of trials while introducing uncontrolled variables, limiting uncontrolled variables while also decreasing the number of trials, or increasing the amount of data collected while reducing the number of trials for each factor tested.
18	TE	Given a diagram of a setup for an investigation of thermal energy transfer and a claim, decide on types of data, how much data, and the accuracy of data needed to produce reliable measurements to support the claim. [Identify the type of data, how much data, and the accuracy of data needed to provide measurements to support the claim that a system undergoing thermal energy transfer will evolve toward equilibrium.]	Drop-down interaction. Include menus placed strategically on labels of the diagram of the system undergoing thermal transfer, such that at each point students decide one of the three data dimensions (i.e., type, how much, accuracy). Menus should contain one example of each data dimension (only one correct dimension) plus 1-3 extraneous dimensions. Correct responses will show all selections correctly. Partial credit would be given for a subset of correct responses. For accuracy of instrumentation refer to as accurate to the hundredths place, etc. (focus is on significant figures. Answer is limited to the precision/uncertainty of the least precise instrument.)
19	TE	Modify a diagram to represent an investigation setup that will test the claim described. [Modify the diagram to show how to test the claim that temperature difference affects transfer of thermal energy.]	Drag-drop interaction. Correct responses will show all required associations that modify the diagram as intended. Partial credit would be given for a subset of correct responses.

#	Item Type	Model Stem (Items ask students to...)	Response Characteristics*
20	MC	Identify or justify the independent, dependent, and/or controlled variables in an investigation set up to measure transfer of thermal energy. [In this investigation, why is composition of material important to consider?] [What is one variable the students should control to increase the accuracy of results in this investigation?]	Distractors may include independent and dependent variables as well as variables that may be/are controlled.

Student Misconceptions:

*Response options can make use of Student Misconceptions (examples of scientifically incorrect assumptions) related to this performance expectation; references to misconceptions are listed in the links below:

- Perceptions of hot or cold are unrelated to energy transfer.
- The temperature of an object depends on its size.
- Heat and cold flow like liquids (e.g., if hands become cold it is because cold is flowing into them).
- Temperature can be transferred.
- Hot objects naturally cool down and cold objects naturally warm up.
- Hot and cold temperatures are properties of substances (e.g., metal objects are cold, polystyrene objects are room temperature).
- Heat always rises.
- Water cannot be at 0°C.
- Ice is at 0°C and/or cannot change temperature.
- Heat and cold are substances.
- Some materials, like wool, have the ability to warm things up.
- Thermal energy is not related to the kinetic energy of the molecules that make up an object.
- Motion energy is not transformed into thermal energy, especially when there is no noticeable temperature increase.
- When two objects at different temperatures are in contact with each other, thermal energy is transferred from the warmer object to the cooler object and “coldness” or “cold energy” is transferred from the cooler object to the warmer object .
- The thermal energy of an object is not related to the mass of the object.
- The thermal energy of an object is not related to the temperature of the object.
- Only things that are warm or hot have thermal energy.
- Cold/frozen objects do not have any thermal energy.
- Thermal energy is not related to the speed of the molecules that make up an object.
- Thermal energy is not related to the number of molecules that make up an object.
- Thermal energy is not related to the type of molecules that make up an object.
- Thermal energy will continue to be transferred by conduction even after the objects in contact with each other reach the same temperature; the temperature of the object getting warmer will continue to increase and the temperature of the object getting cooler will continue to decrease.
- When a cold and a warm object are placed in contact with each other, the warm object gets colder and the cold object gets warmer because “coldness” is transferred from one object to the other.

Waves and Their Applications in Technologies for Information Transfer: PS.PS4.1

back to “Item Specifications by Performance Expectation”

PS.PS4.1. Use mathematical representations to explain both qualitative and quantitative relationships among frequency, wavelength, and speed of waves traveling in various media.

OAS-S Clarification Statement:

Emphasis is on using mathematical representations to understand how various media change the speed of waves. Examples of waves moving through various media could include: electromagnetic radiation traveling in a vacuum or glass, sound waves traveling through air or water, or seismic waves traveling through Earth.

OAS-S Assessment Boundary:

Assessment is limited to algebraic relationships and describing those relationships qualitatively.

Science & Engineering Practice:	Disciplinary Core Idea:	Crosscutting Concept:
<p>Mathematical and Computational Thinking</p> <ul style="list-style-type: none"> Use mathematical representations of phenomena or design solutions to describe and/or support claims and/or explanations. 	<p>Wave Properties</p> <ul style="list-style-type: none"> The wavelength and frequency of a wave are related to one another by the speed of travel of the wave, which depends on the type of wave and the medium through which it is passing. 	<p>Cause and Effect</p> <ul style="list-style-type: none"> Empirical evidence is required to differentiate between cause and correlation and make claims about specific causes and effects.

In Lay Terms:

Students should be able to use mathematical representations (e.g., mathematical expressions, simple algebraic functions represented in diagrams, models, equations, tables, and graphs, including seismographs, sonograms [whale]) to demonstrate qualitatively and quantitatively the following:

- The speed at which a wave travels is related to the wave’s frequency and wavelength.
- There are two classes of waves: transverse and longitudinal. These two classes of waves have different characteristics.
- A wave’s speed and wavelength can be affected by the material through which it travels.
- The frequency of a wave is unaffected by changes in media.

Cluster Clarifications:

- The focus of this PE goes beyond mechanical waves, although students are not responsible for identifying the terms “transverse” and “longitudinal.”
- Although students are using algebraic relationships, they are only describing these relationships qualitatively.
- Students may be asked to explain given calculations but are not responsible for doing calculations. Note that focus is on conceptual understanding (no plug and chug or algorithms).
- Describe frequency in hertz (base unit).
- Describe speed of wave in m/sec (base unit).
- Unit for wavelength will depend on context (base unit = meters).
- All units should be consistent across measurements such that students are not converting units.

Waves and Their Applications in Technologies for Information Transfer: PS.PS4.1

Cluster Stimulus Attributes:

Typical stimulus elements:

- graphs
- data tables showing frequency, speed, and wavelength plus media
- diagrams
- text descriptions
- algebraic equations and expressions
- computational simulations

Possible contexts:

- blue LED (frequency and wavelength only)
- sound waves to determine blockages in pipes
- sound waves as fire suppression
- echolocation (the “human bat” or real bats)
- filtration of different wavelengths of light at different depths of ocean
- Why is sunset orange?
- sun dogs
- size of instruments (tuba, bass, not French horn, avoid length of pipe)
- sound waves in swimming pool versus air (voice underwater)
- scuba diver communication (metal rod banging on tank)
- feeling the bass but not hearing the words when a car pulls up
- how density affects the vibration of the strings of a musical instrument
- Rayleigh scattering
- movement of light through gelatin
- sound moving through air of different densities
- sound moving through air of different temperatures
- wave traveling through ropes of different thicknesses (or wave machine set up with different densities)
- ground motion during earthquake through solid bedrock and into muddy/filled area (media of different densities); through shadow zones, Mohorovičić discontinuity (moho)
- Rubens’ tube
- musical Tesla coil
- determining habitability of planets based on spectrum
- earthquake waves—difference in speed compared to tsunamis (water) (~100 times faster)
- speed of sound through helium versus sulfur hexafluoride

Content and evidence to be included: pictures, text descriptions, graphs, tables, models/diagrams, or other relevant information about waves in different media

Types of student responses that need to be supported: displaying mathematical representations and describing relationships seen in models/graphs/data of waves in different media; explaining and predicting wave characteristics (wavelength/frequency/speed) using models/graphs/data

Allowable Item Types:

- MC
- TEI

Model Item Descriptions for PS.PS4.1:

#	Item Type	Model Stem (Items ask students to...)	Response Characteristics*
1	MC	Choose the most appropriate mathematical representation for parts or relationships in the system. [Which mathematical representation (graph) best represents the relationship among frequency, wavelength, and speed (using the data in the table)?]	Key may focus on the mathematical representation that best illustrates the specified parts or relationships. Distractors may include expressions that contain a subset of the factors seen in the correct expression or that contain similar but not identical factors. Mathematical representations should be graphs of frequency versus wavelength
2	MC	Make a conclusion or claim describing what the mathematical representation shows about wave movement through different media. [Which statement best describes what the graph shows about the change in wave speed as a wave moves from air into water?]	Key may focus on describing what the representation illustrates overall about wave movement. Distractors may include unsupported claims or claims that misstate the relationship among frequency, wavelength, and speed.
3	MC	Relate the mathematical representation to the claim/describe how the mathematical representation links to the concept (in the claim). [How do the mathematical relationships shown in the table/graph/equation relate to the student's claim about the relationships between wave speed and wavelength for the samples shown?]	Key may focus on how the mathematical representation provides support for the concept presented in the claim (reasoning with content). Distractors may include explanations that misinterpret the relationship described in the expression or representation.
4	MC	Use mathematical data to select/support a claim about the relationships among wavelength, frequency, and/or speed as waves move through different media. [Based on the data, which claim about the relationship among wavelength/frequency/speed is supported?]	Key may focus on correlations between two of the three variables. Distractors may include statements describing inverse/tangential/irrelevant relationships to those seen in the data (per common misconceptions) or comparisons of uncorrelated data.
5	MC	Predict how and why a mathematical representation would change due to a change in medium, given data. [Which graph shows how the wave will change as it enters the ocean?]	Key (graph) should be based on research and show all necessary attributes (speed, wavelength, frequency). Distractors may include incorrect predictions or be based on misconceptions or misinterpretations of the data.
6	MC	Analyze diagrams of waves to determine which has the greatest speed.	Distractors may contain waves of varying wavelength and frequency. This is conceptual; no formula required.

#	Item Type	Model Stem (Items ask students to...)	Response Characteristics*
7	MC	<p>Use data to support claims related to relationships among variables within the equation $v = f\lambda$.</p> <p>[Which data support the students' claim that there is a direct relationship between wavelength and speed of waves?]</p> <p>[A student claimed that the wave speed for a particular type of wave traveling through a particular medium will always be constant. Which data support this claim?]</p>	<p>Distractors may include misinterpretations/misconceptions of relationships or incorrect explanations of the evidence.</p> <p>Define variables in stimulus: frequency (f)</p>
8	MC	<p>Explain the reason for a particular difference in the characteristic of waves.</p> <p>[Which of the following explains why the speed of the wave differed as it left the gelatin?]</p>	<p>Distractors may include misinterpretations/misconceptions of relationships or incorrect explanations of the evidence.</p>
9	MC	<p>Identify which evidence from the mathematical representation best supports the claim about the relationships among wavelength, energy, and/or speed as waves move through different media.</p>	<p>Key may focus on data directly supporting the claim.</p> <p>Distractors may include claims describing relationships varying from those indicated in the data table, irrelevant relationships (per common misconceptions) or comparisons of uncorrelated data.</p> <p>Limit questions to variables described in the stimulus/stem.</p>
10	MC	<p>Compare and justify which of two or more alternate claims is best supported based on the mathematical representation/data.</p> <p>[Which claim is the most consistent with the way waves travel through the different media, and why?]</p>	<p>Key may focus on the validity of one claim over another in terms of the patterns shown in the data.</p> <p>Claims may focus on the cause-and-effect relationship seen between media types and wave characteristics, or the correlations seen among wave characteristics as represented by $v = f\lambda$.</p> <p>Distractors may include claims/justifications that are inconsistent with the data presented or are incorrect interpretations of the various claims based on misconceptions.</p>
11	TE	<p>Given a mathematical representation and a list of claims about the properties of waves traveling through two different media, distinguish those that are supported from those that are unsupported by the given representation.</p> <p>[Select all of the claims about properties of waves that are supported by the model the scientists created.]</p>	<p>Interaction type may be drag-drop (sorting which claims are supported) or matching.</p> <p>Claims to evaluate may include those that represent misconceptions or invalid interpretations of the data.</p> <p>Claims may focus on the cause-and-effect relationship seen between media types and wave characteristics, or the correlations seen among wave characteristics as represented by $v = f\lambda$.</p> <p>Correct responses show the multiple claims that are supported by the data.</p> <p>Partial credit would be awarded for a subset of correct responses.</p>

#	Item Type	Model Stem (Items ask students to...)	Response Characteristics*
12	MC	Analyze tables/graphs of waves to predict changes in characteristics. [How will the speed of this wave change if its frequency is changed to 3 cycles per second (Hz)?] [How will the wavelength of this wave change as it moves into the aluminum wall? (graph of wave, plus table of speeds of sounds for different materials given)] [Which of the changes will cause the biggest increase in the speed of the wave?]	Distractors may include incorrect interpretations of patterns or incorrect explanations of relationships. Item should focus on conceptual understanding, not calculations. To target conceptual understanding, items may ask for approximations.
13	MC	Use evidence to support a claimed cause-and-effect relationship. [Students claimed there is a cause-and-effect relationship between type of medium and speed of light. What data best support this claim?]	Key may focus on specific data that support the relationship. Distractors may include evidence that supports correlation instead of cause-effect or that supports neither relationship.

Student Misconceptions:

*Response options can make use of Student Misconceptions (examples of scientifically incorrect assumptions) related to this performance expectation; references to misconceptions are listed in the links below:

- Sound requires an absence of a medium to travel (this is connected to students' ideas that air is empty and not made of matter).
- Sounds cannot travel through liquids and solids.

From Conceptual Curriculum for Physics. National Science Foundation, 16 07 2009.

- Waves do not have energy.
- All waves travel the same way.
- Big waves travel faster than small waves in the same medium.
- Different colors of light are different types of waves.
- Wave speed and frequency are the same thing.
- Light is a particle.
- There is no interaction between light and matter.

static.nsta.org/connections/elementaryschool/201404Schleigh.pdf

- Different wavelengths of light have different energy and therefore different speeds.

Waves and Their Applications in Technologies for Information Transfer: PS.PS4.4

back to “Item Specifications by Performance Expectation”

PS.PS4.4. Evaluate the validity and reliability of claims in published materials of the effects that different frequencies of electromagnetic radiation have when absorbed by matter.

OAS-S Clarification Statement:

Emphasis is on the idea that different frequencies of electromagnetic radiation have different energies, and the damage to living tissue depends on the energy of the radiation. Examples of published materials could include peer-reviewed scientific articles, or trade books, magazines, web resources, videos, and other passages that may reflect bias.

OAS-S Assessment Boundary:

Assessment is limited to qualitative descriptions.

Science & Engineering Practice:	Disciplinary Core Idea:	Crosscutting Concept:
<p>Obtaining, Evaluating, and Communicating Information</p> <ul style="list-style-type: none"> Evaluate the validity and reliability of multiple claims that appear in scientific and technical texts or media reports, verifying the data when possible. 	<p>Electromagnetic Radiation</p> <ul style="list-style-type: none"> When light or longer wavelength electromagnetic radiation is absorbed in matter, it is generally converted into thermal energy (heat). Shorter wavelength electromagnetic radiation (ultraviolet, X-rays, gamma rays) can ionize atoms and cause damage to living cells. Photoelectric materials emit electrons when they absorb light of a high-enough frequency. 	<p>Cause and Effect</p> <ul style="list-style-type: none"> Cause and effect relationships can be suggested and predicted for complex natural and human designed systems by examining what is known about smaller scale mechanisms within the system.

In Lay Terms:

Students will evaluate multiple claims published in scientific and non-scientific sources about the effects of different frequencies of electromagnetic radiation on matter. For each claim they will consider reliability and validity:

- Reliability is the degree to which a tool or procedure gives the same result repeatedly.
- Validity is the degree to which an investigation accurately measures the concept a researcher is attempting to measure.
- Note that a study can consistently measure the wrong thing (be reliable), yet still be invalid.

Cluster Clarifications:

- In the hierarchy of scientific evidence, the strongest evidence results from randomized controlled trials. Case reports and expert opinion are examples of weaker evidence.
- To make the assessment accessible to students from all three content areas, photoelectric materials (DCI bullet 3) will not be assessed.
- Describe frequency in hertz (base unit).
- Describe speed of wave in m/sec (base unit).
- Unit for wavelength will depend on context (base unit = meters).
- All units should be consistent across measurements such that students are not converting units.
- Validity and reliability should be defined in stimulus when used in items.

Waves and Their Applications in Technologies for Information Transfer: PS.PS4.4

Cluster Stimulus Attributes:

Typical stimulus elements:

- two passages containing data tables, diagrams, and text
- one passage with two competing claims

Possible contexts:

- cell phones and brain tumors
- microwave ovens
- transmitters and antennas
- blue light and melatonin suppression (poor sleeping)
- millimeter wave scanners (at airports)
- X-rays and CAT scans as diagnostic tools
- MRIs as diagnostic tools
- solar flares (quackery)
- UVA/UVB light and skin cancer; sunburns on a cloudy day
- tanning beds and kids; non UV versus UV beds
- lasers
- electromagnetic “hypersensitivity” (exposure to power lines, cell phone towers, Wi-Fi networks, fluorescent lights, microwaves, mobile phones, wireless meter sickness)
- pulsed electromagnetic fields as health tool, “EMP pad”

Content and evidence to be included: Contrasting passages regarding effects on living tissue by electromagnetic radiation. Passages should contrast in terms of validity and reliability (e.g., peer-reviewed article or general interest describing peer-reviewed versus sensationalized story or advertisement, or two scientific studies that vary in quality). Alternatively, passage may present a claim and two different articles in which students consider which article tests the claim best, or improper interpretation of results toward a biased viewpoint.

Types of student responses that need to be supported: supporting inferences about validity/reliability of sources of claims; comparing validity/reliability of sources of claims; analyzing data and procedures to describe cause-and-effect reasoning of claims; or analyzing, supporting, or rejecting claims about effects of living tissue by electromagnetic radiation

Allowable Item Types:

- MC
- TEI

Model Item Descriptions for PS.PS4.4:

#	Item Type	Model Stem (Items ask students to...)	Response Characteristics*
1	MC	<p>Support inferences about the reliability/ validity of the sources of claims about effect of electromagnetic radiation absorbed by matter with evidence.</p> <p>[What evidence suggests that this is a valid source?]</p> <p>[What evidence suggests that this source is not reliable?]</p>	<p>Key may include evidence of illogical (sloppy) patterns of thinking, bias, implausible assumptions.</p>
2	TE	<p>Support inferences about the reliability/ validity of the sources of claims about effect of electromagnetic radiation absorbed by matter with evidence.</p> <p>[Select the evidence that supports that this is a valid source.]</p>	<p>Hot-spot interaction.</p> <p>A minimum of three and a maximum of four correct associations should be used.</p> <p>Correct responses show all required associations/locations.</p> <p>Partial credit would be given for a subset of correct responses.</p>
3	MC	<p>Compare the validity or reliability of the sources of a claim.</p> <p>[Which source is more reliable, and why?]</p> <p>[Which source is more valid, and why?]</p> <p>[What makes claim X less credible than claim Y?]</p>	<p>Key may include evidence of illogical (sloppy) patterns of thinking, bias, implausible assumptions.</p>
4	MC	<p>Describe the cause-and-effect reasoning made in a claim related to the effects that different frequencies of electromagnetic radiation have when absorbed by matter.</p> <p>[Based on the evidence in the data table, how do changes caused by microwave radiation at the cellular level affect an animal at larger scales?]</p> <p>[Based on the information in the graph and diagram, how do solar flares affect pilots?]</p>	<p>Cause-and-effect reasoning in the key should extrapolate from the mechanism seen at small scale to the entire organism.</p> <p>Possible contexts may include: use of gold-coated visors by astronauts, fake solar eclipse glasses.</p>
5	MC	<p>Reason about the data presented to analyze the validity of a claim related to the effects that different frequencies of electromagnetic radiation have when absorbed by matter.</p> <p>[How is the scientist's claim about the effect of blue lights on the sleep cycle affected by the lack of data from 2001 to 2005?]</p> <p>[How is the writer's claim about the effect of high tension power lines on health affected by the method used to randomize groups in this study?]</p> <p>[How is the student's claim about the effect of EMP pads affected by the fact that the researchers and test subjects were able to tell the difference between the EMP pad and the control pad?]</p>	<p>Key may focus on data measurement or reporting that demonstrates either validity or the lack thereof in relation to the claim/ conclusion being made.</p> <p>Distractors may include characteristics of the data that do not affect validity.</p>

#	Item Type	Model Stem (Items ask students to...)	Response Characteristics*
6	MC	<p>Reason about the data presented to analyze the reliability of a claim related to the effects that different frequencies of electromagnetic radiation have when absorbed by matter.</p> <p>[How does the experiment setup affect the reliability of the claim being made about Wi-Fi allergies? (e.g., variability in Wi-Fi signal from trial to trial)]</p> <p>[What does the response data suggest about the reliability of the claim being made about Wi-Fi allergies? (e.g., inconsistency in following of method, variability in self-reporting)]</p>	<p>Key may focus on data measurement or reporting that demonstrates either reliability or the lack thereof in relation to the claim/ conclusion being made.</p> <p>Distractors may include characteristics of the data that do not affect reliability.</p>
7	MC	<p>Analyze the validity of competing claims related to the effects that different frequencies of electromagnetic radiation have when absorbed by matter.</p> <p>[Based on the evidence presented in the excerpts, which claim is more valid, and why?]</p> <p>[What can be concluded about the validity of each claim based on the information about cell damage caused by exposure to radiation?]</p> <p>[What can be concluded about the validity of each claim based on the information about relative wavelengths of the photons involved in this process?]</p>	<p>Key should focus on the relative quality of the experimental design for each investigation. Factors relating to design quality might include internal validity concerns such as sample size and composition, participant and investigator “blinding,” changes in instrumentation, loss of subjects, and external validity concerns such as applicability of results to a larger sample/real world (e.g., results of a solar flare study on pilots may not be applicable to people who fly less often).</p>
8	MC	<p>Analyze the reliability of competing claims related to the effects that different frequencies of electromagnetic radiation have when absorbed by matter.</p> <p>[Based on the information presented in each excerpt, which claim is more reliable, and why?]</p>	<p>Key should examine the cause-and-effect relationship seen at the atomic/cellular scale.</p>
9	MC	<p>Distinguish the changes to an investigation that will improve the scientific reliability of an argument or conclusion related to the effects that different frequencies of electromagnetic radiation have when absorbed by matter.</p> <p>[Which change to the procedure would best improve the reliability of the scientists’ explanation about the effect of UVA rays on skin cells?]</p>	<p>Key may focus on changes such as additional studies, or repetition of the investigation, or consistency of procedure.</p> <p>Distractors may include changes that do not improve the reliability or information unrelated to the argument/conclusion.</p>
10	MC	<p>Describe changes to an investigation setup that will best improve the scientific validity of a claim related to the effects that different frequencies of electromagnetic radiation have when absorbed by matter.</p> <p>[Which change to the procedure would improve the validity of the scientists’ explanation about the effect of millimeter wave scanners on human health?]</p>	<p>Key may focus on changes that offer better control of variables, randomization of groups, “blinding” of researchers and/or subjects, or poor experimental design.</p> <p>Distractors may include changes that do not improve the validity or information unrelated to the argument/conclusion.</p> <p>To meet CCC, focus on the small-scale (atomic/cellular) mechanism within the system.</p>

#	Item Type	Model Stem (Items ask students to...)	Response Characteristics*
11	TE	Select the changes to the procedure that will improve the reliability OR validity of an investigation related to effects that different frequencies of electromagnetic radiation have when absorbed by matter.	Hot-spot interaction. A minimum of three and a maximum of four correct associations should be used. Correct responses show all required associations/locations. Partial credit would be given for a subset of correct responses. Individual items should focus on reliability OR validity, not both.

Student Misconceptions:

*Response options can make use of Student Misconceptions (examples of scientifically incorrect assumptions) related to this performance expectation; references to misconceptions are listed in the links below:

- Only the sun transfers energy in the form of electromagnetic radiation.
- Only hot objects can transfer energy in the form of electromagnetic radiation.
- Only objects that are glowing can transfer energy in the form of electromagnetic radiation.
- Energy is not transferred from one object to another unless those objects are in direct contact with each other.

From static.nsta.org/connections/elementaryschool/201404Schleigh.pdf

- A radio wavelength is a sound wave not part of the electromagnetic spectrum.

From *Conceptual Curriculum for Physics*. National Science Foundation, 16 07 2009.

- Waves do not have energy.
- Different colors of light are different types of waves.
- Light is a particle.
- There is no interaction between light and matter.

APPENDIX: ALIGNMENT AND COGNITIVE COMPLEXITY EVALUATION TOOL

Alignment and Cognitive Complexity Evaluation Tool

Use this screener tool to evaluate the items independently and then the cluster overall.

Alignment to the dimensions

To what extent does the item require the student to engage with the dimension (low, medium, and high). We first evaluate the SEP, CCC, and DCI individually as part of assigning a cognitive complexity ranking to the item. The below scale is used to evaluate individual dimensions. If an item is lacking a dimension (Oklahoma requires a minimum of two dimensions be present in any one item) indicate that with N/A in the box.

SEP (SCIENCE AND ENGINEERING PRACTICE)	
Questions to help determine how students' use of the SEP contributes to cognitive complexity/sense-making in the item: <ul style="list-style-type: none"> • How is the SEP being used to explore/understand the phenomenon? • How much scaffolding is provided for students to use the SEP? • Is the SEP used independently of any occurrence in the DCI or CCC? (No double counting) 	
Low	<ul style="list-style-type: none"> • Students only need to use the SEP in a simple, straightforward way that is absent of or minimally uses sense-making • Large amounts of scaffolding are supplied to help the students apply the SEP • Isolated component of SEP is used
Medium	<ul style="list-style-type: none"> • Students must apply the SEP to make sense of the phenomenon • Typically some scaffolding is provided that helps students apply the SEP
High	<ul style="list-style-type: none"> • Students must apply the SEP to make sense of the phenomenon (e.g., synthesis to perform more connections. SEP elements are used in combination, such as having to combine data, produce a new graph or model as evidence, etc.) • Often little to no scaffolding is in place to help students apply the SEP • The SEP is used in sense-making that bridges across diverse contexts

DCI (DISCIPLINARY CORE IDEA)	
Questions to help determine how students' use of the DCI contributes to cognitive complexity/sense-making in the item: <ul style="list-style-type: none"> • How do the DCIs contribute to sense-making as the student engages with the phenomenon? • How much scaffolding is provided for students to use the DCI? • Is the DCI used independently of any occurrence in the SEP or CCC? (No double counting) 	
Low	<ul style="list-style-type: none"> • Students use the DCI in a simple, straightforward way (e.g., little to no application or reasoning) • Often a large amount of scaffolding that helps students apply the DCI • Producing previously learned ideas and conceptual procedures in routine, well-practiced ways
Medium	<ul style="list-style-type: none"> • Students must apply or reason with DCI concepts to make sense of the phenomenon • Supported applications of science ideas in typical contexts • Some scaffolding that helps students apply the DCI
High	<ul style="list-style-type: none"> • Students must apply and connect DCI concepts in a sophisticated way to make sense of the phenomenon, e.g., <ul style="list-style-type: none"> ○ application of science ideas (often multiple ideas) in new ways or combinations ○ knowledge transfer to construct new understanding, make sense of novel phenomena • Often little to no scaffolding that helps students apply the DCI • There is some uncertainty associated with the outcome of the scenario

CCC (CROSSCUTTING CONCEPT)

Question to help determine how students' use of the CCC contributes to cognitive complexity/sense-making in the item:

- How is the lens of the CCC used to understand the phenomenon?
- How much scaffolding is provided for students to use the CCC?
- Is the CCC used independently of any occurrence in the SEP or DCI? (No double counting)

Low	<ul style="list-style-type: none">• CCCs are implicitly part of the task, but they are not required in service of sense-making
Medium	<ul style="list-style-type: none">• Students use the CCC in a general way (e.g., item includes and/or could have students use the general CCC concept)• Used for minimal sense making
High	<ul style="list-style-type: none">• Students use the CCC in an in-depth way (e.g., drawing on the understandings of the CCC sub-bullet detail to make sense of the phenomenon)• Used in part or fully to bridge a gap in DCI knowledge and/or sense making

Stimulus Question

Can the questions of the task be answered without using information provided by the task scenario or context?
Yes ! or No

Cognitive Complexity Table

Category	Description
Scripted	<ul style="list-style-type: none"> • Only one dimension is present, or two dimensions are present but only one is used in application or reasoning for sense-making. • Heavy scaffolding <ul style="list-style-type: none"> ○ Scripted “Cookbook instructions” • Little to no sense making
Moderate Support	<ul style="list-style-type: none"> • Multidimensional 2-3 dimensions are evident but only one is heavily used in sense-making while the other may be used minimally. • Moderate scaffolding <ul style="list-style-type: none"> ○ Students have to apply ideas and practices; however, they are often told which ones to engage with and supported in using them • Low to Medium degree of sense making
Low Support	<ul style="list-style-type: none"> • Multidimensional 2-3 dimensions are evident with at least 2 being necessary to use or reason within sense-making. • Minimal scaffolding <ul style="list-style-type: none"> ○ Students are cued and guided to pursue certain lines of thinking, but have to make some decisions about how and what to engage • Medium to High degree of sense making <ul style="list-style-type: none"> ○ High: Students must connect multiple pieces of information in a novel way
Doing (rarely achievable on summative assessments)	<ul style="list-style-type: none"> • The three dimensions are used together to engage in sense-making to a high degree throughout the task • Student-designed exploration of science • Limited to no scaffolding • Students work like scientists to use various scientific practices to be able to develop or deepen an understanding of a scientific idea or problem as they explore a phenomenon. In most cases if a student actually is engaged in 3 dimensions and has to develop the model or develop the explanation or develop the argument from raw data or information, they are being asked to do science.

Note: These descriptions are adapted from Achieve



OKLAHOMA
Education